

# ZODIAC XL

## SLSA

CONTINENTAL 0-200 100 H.P.

# PILOT OPERATING HANDBOOK



REGISTRATION:

SERIAL NUMBER:

## PILOT OPERATING HANDBOOK

**Model:**

**Serial No:**

**Registration:**

**Date of Issue:**

**THERE ARE INHERENT RISKS IN THE PARTICIPATION IN RECREATIONAL AVIATION AIRCRAFT. OPERATORS AND PASSENGERS OF RECREATIONAL AIRCRAFT, BY PARTICIPATION, ACCEPT THE RISK INHERENT IN SUCH PARTICIPATION ON WHICH THE ORDINARY PRUDENT PERSON IS OR SHOULD BE AWARE. PILOTS AND PASSENGERS HAVE A DUTY TO EXERCISE GOOD JUDGEMENT AND ACT IN A RESPONSIBLE MANNER WHILE USING THE AIRCRAFT AND TO OBEY ALL ORAL OR WRITTEN WARNINGS, OR BOTH, PRIOR TO OR DURING USE OF THE AIRCRAFT, OR BOTH.**

**THIS AIRCRAFT WAS MANUFACTURED IN ACCORDANCE WITH LIGHT SPORT AIRCRAFT AIRWORTHINESS STANDARDS AND DOES NOT CONFORM TO STANDARD CATEGORY AIRWORTHINESS REQUIREMENTS**

**Date of issue: December 2005**

This airplane is to be operated in compliance with the information and limitations contained herein.

**SECTION 0**  
**ZODIAC XL-SLSA WITH 0-200 ENGINE**

**PILOT OPERATING HANDBOOK**  
**List of Effective Pages**

| Section | Page    | Date    | Section | Page    | Date    | Section | Page    | Date    |         |  |
|---------|---------|---------|---------|---------|---------|---------|---------|---------|---------|--|
| 0-0     | 0-1     | Dec. 05 | 6-0     | 6-1     | Dec. 05 | 8-9     | 8-9     | Dec. 05 |         |  |
|         | 0-2     | Dec. 05 |         | 6-2     | Dec. 05 |         | 8-10    | Dec. 05 |         |  |
|         | 0-3     | Dec. 05 |         | 6-3     | Dec. 05 |         | 8-11    | Dec. 05 |         |  |
|         | 0-4     | Dec. 05 |         | 6-4     | Dec. 05 |         | 8-12    | Dec. 05 |         |  |
|         |         |         |         | 6-5     | Dec. 05 |         | 9-0     | 9-1     | Dec. 05 |  |
| 1-0     | 1-1     | Dec. 05 | 6-6     | Dec. 05 | 9-2     | Dec. 05 |         |         |         |  |
| 2-0     | 2-1     | Dec. 05 | 6-7     | Dec. 05 | 9-3     | Dec. 05 |         |         |         |  |
|         | 2-2     | Dec. 05 | 6-8     | Dec. 05 | 10-0    | 10-1    | Dec. 05 |         |         |  |
| 2-3     | Dec. 05 | 6-9     | Dec. 05 | 10-2    |         | Dec. 05 |         |         |         |  |
| 2-4     | Dec. 05 | 7-0     | 7-1     | Dec. 05 |         | 10-3    | Dec. 05 |         |         |  |
| 2-5     | Dec. 05 |         | 7-2     | Dec. 05 |         | 10-4    | Dec. 05 |         |         |  |
| 2-6     | Dec. 05 |         | 7-3     | Dec. 05 | 10-5    | Dec. 05 |         |         |         |  |
| 2-7     | Dec. 05 |         | 7-4     | Dec. 05 | 10-6    | Dec. 05 |         |         |         |  |
| 3-0     | 3-1     | Dec. 05 | 7-5     | Dec. 05 | 10-7    | Dec. 05 |         |         |         |  |
|         |         |         | 7-6     | Dec. 05 | 10-8    | Dec. 05 |         |         |         |  |
| 4-0     | 4-1     | Dec. 05 | 7-7     | Dec. 05 | 11-0    | 11-1    | Dec. 05 |         |         |  |
|         | 4-2     | Dec. 05 | 7-8     | Dec. 05 |         | 11-2    | Dec. 05 |         |         |  |
|         | 4-3     | Dec. 05 | 7-9     | Dec. 05 |         | 11-3    | Dec. 05 |         |         |  |
|         | 4-4     | Dec. 05 | 7-10    | Dec. 05 | 12-0    | 12-1    | Dec. 05 |         |         |  |
|         | 4-5     | Dec. 05 | 7-11    | Dec. 05 |         |         |         |         |         |  |
|         | 4-6     | Dec. 05 | 7-12    | Dec. 05 |         |         |         |         |         |  |
|         | 4-7     | Dec. 05 | 7-13    | Dec. 05 |         |         |         |         |         |  |
|         | 4-8     | Dec. 05 | 7-14    | Dec. 05 |         |         |         |         |         |  |
| 5-0     | 5-1     | Dec. 05 | 7-15    | Dec. 05 | 8-0     |         |         |         |         |  |
|         |         |         | 5-2     | Dec. 05 |         |         |         | 8-1     | Dec. 05 |  |
|         |         |         | 5-3     | Dec. 05 |         |         |         | 8-2     | Dec. 05 |  |
|         |         |         | 5-4     | Dec. 05 |         |         |         | 8-3     | Dec. 05 |  |
|         |         |         | 8-4     | Dec. 05 |         |         |         |         |         |  |
|         |         |         | 8-5     | Dec. 05 |         |         |         |         |         |  |
|         |         |         | 8-6     | Dec. 05 |         |         |         |         |         |  |
|         |         |         | 8-7     | Dec. 05 |         |         |         |         |         |  |
|         |         |         | 8-8     | Dec. 05 |         |         |         |         |         |  |

**SECTION 0**  
**ZODIAC XL-SLSA WITH 0-200 ENGINE**

---

**REVISIONS**

**PILOT OPERATING HANDBOOK  
UPDATE LOG**

| <b>REV. NO.</b> | <b>DATE ISSUED</b> | <b>DATE INCORPORATED</b> | <b>INSERTED BY</b> |
|-----------------|--------------------|--------------------------|--------------------|
| <b>0</b>        | <b>DEC. 05</b>     | <b>DEC. 05</b>           | <b>AMD</b>         |
|                 |                    |                          |                    |
|                 |                    |                          |                    |
|                 |                    |                          |                    |
|                 |                    |                          |                    |
|                 |                    |                          |                    |
|                 |                    |                          |                    |
|                 |                    |                          |                    |
|                 |                    |                          |                    |
|                 |                    |                          |                    |
|                 |                    |                          |                    |
|                 |                    |                          |                    |
|                 |                    |                          |                    |
|                 |                    |                          |                    |
|                 |                    |                          |                    |
|                 |                    |                          |                    |
|                 |                    |                          |                    |
|                 |                    |                          |                    |
|                 |                    |                          |                    |
|                 |                    |                          |                    |
|                 |                    |                          |                    |

Note: page 0-2 must be replaced for each new update.

Copyright AMD

The data and information contained in the document is the property of AMD. This document may not be reproduced or transmitted to a third party, in any form or by any means. Any unauthorized copy, distribution is illegal as per international agreements relating to property rights.

## **TABLE OF CONTENTS**

|                   |  |
|-------------------|--|
| <b>SECTION 0</b>  | <b>REVISIONS</b>                         |
| <b>SECTION 1</b>  | <b>GENERAL</b>                           |
| <b>SECTION 2</b>  | <b>AIRPLANE AND SYSTEMS DESCRIPTION</b>  |
| <b>SECTION 3</b>  | <b>OPERATING LIMITATIONS</b>             |
| <b>SECTION 4</b>  | <b>WEIGHT AND BALANCE INFORMATION</b>    |
| <b>SECTION 5</b>  | <b>PERFORMANCE</b>                       |
| <b>SECTION 6</b>  | <b>EMERGENCY PROCEDURES</b>              |
| <b>SECTION 7</b>  | <b>NORMAL PROCEDURES</b>                 |
| <b>SECTION 8</b>  | <b>AIRCRAFT HANDLING AND MAINTENANCE</b> |
| <b>SECTION 9</b>  | <b>REQUIRED PLACARDS AND MARKINGS</b>    |
| <b>SECTION 10</b> | <b>SUPPLEMENTARY INFORMATION</b>         |
| <b>SECTION 11</b> | <b>OPTIONS</b>                           |
| <b>SECTION 12</b> | <b>FAMILIERIZATION FLIGHT PROCEDURES</b> |

## **SECTION 1**

### **GENERAL**

#### **WARNING**

**THE OWNER AND OPERATOR MUST UNDERSTAND THAT DUE TO INHERENT RISK INVOLVED IN FLYING AN AIRCRAFT, NO WARRANTY IS MADE OR IMPLIED, OF ANY KIND, AGAINST ACCIDENTS, BODILY INJURY OR DEATH OTHER THAN THOSE, WHICH CANNOT BY LAW BE EXCLUDED.**

**THE SAFE OPERATION OF THIS AIRCRAFT RESTS WITH YOU, THE PILOT. WE BELIEVE THAT IN ORDER TO FLY SAFELY YOU MUST MATURELY PRACTICE AIRMANSHIP. OPERATIONS OUTSIDE THE RECOMMENDED FLIGHT ENVELOPE SUCH AS AEROBATIC MANOEUVRES OR ERRATIC PILOT TECHNIQUE MAY ULTIMATELY PRODUCE EQUIPMENT FAILURE. YOU ARE REFERRED TO THE OPERATING LIMITATIONS IN THIS MANUAL.**

**LIKE ANY AIRCRAFT, SAFETY DEPENDS ON A COMBINATION OF CAREFUL MAINTENANCE AND YOU'RE ABILITY TO FLY INTELLIGENTLY AND CONSERVATIVELY. WE HOPE THAT YOUR AIRCRAFT WILL PROVIDE YOU WITH MANY HOURS OF SAFE AND ENJOYABLE FLYING.**

**SECTION 1**

**GENERAL**

**INTRODUCTION**

This Pilot Operating Handbook (POH) is designed for maximum utilization as an operating guide for the pilot. It includes the material required by the regulations to be furnished to the pilot. It also contains supplemental data supplied by the airplane manufacturer.

This Pilot Operating Handbook is not designed as a substitute for adequate and competent flight instruction, knowledge of current airworthiness directives, applicable air regulations or advisory circulars. It is not intended to be a guide for basic flight instruction or a training manual and should not be used for operational purposes unless kept in a current status.

Assurance that the airplane is in an air worthy condition is the responsibility of the owner. The pilot in command is responsible for determining that the airplane is safe for flight. The pilot is also responsible for remaining within the operating limitations as outlined by instrument markings, placards, and this Pilot Operating Handbook.

Although the arrangement of this Pilot Operating Handbook is intended to maximize its in-flight capabilities, it should not be used solely as an occasional operating reference. The pilot should study the entire Pilot Operating Handbook to become familiar with the limitations, performance, normal and emergency procedures and operational handling characteristics of the airplane before flight.

The Pilot Operating Handbook has been divided into numbered (Arabic) sections. The limitations and emergency procedures have been placed ahead of the normal procedures, performance and other sections to provide easier access to information that may be required in flight. The "Emergency Procedures" Section is quickly available, to present an instant reference. Provisions for expansion and/or updates to this Pilot Operating Handbook (POH) have been made.

Before flying the aircraft, read and familiarize yourself with this POH, the Engine Operators Manual and Maintenance Manual.

**CERTIFICATION BASIS**

**FAA Special Light Sport Aircraft (SLSA) category**

**WARNINGS, CAUTIONS AND NOTES**

The following definitions apply to warnings, cautions and notes used in the Pilot Operating Handbook.

**WARNING:** means that the non-observation of the corresponding procedure leads to an immediate degradation of flight safety which could result in loss of life or destruction of equipment.

**CAUTION:** means that the non-observation of the corresponding procedure leads to a degradation of flight safety resulting in damage to the equipment.

**NOTE:** draws the attention to any item that is important or unusual.

**SECTION 2**

**AIRPLANE AND SYSTEMS DESCRIPTION**

**SAMPLE**



**SECTION 2**  
**ZODIAC XL-SLSA WITH 0-200 ENGINE**

---

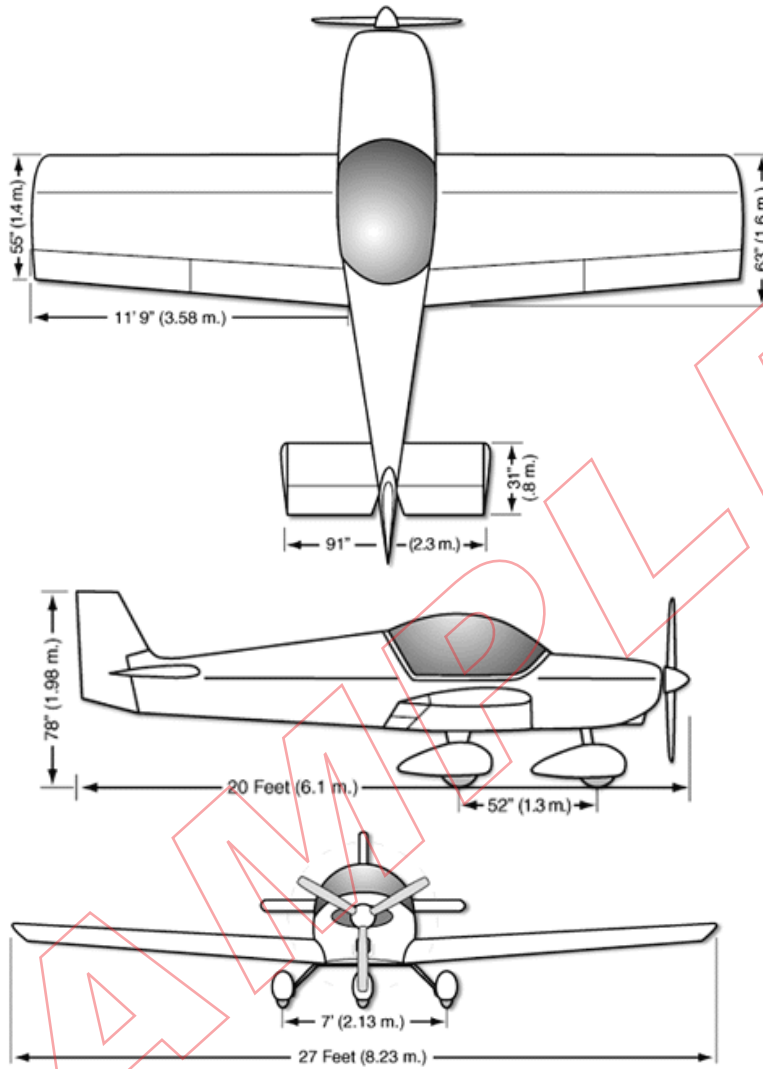

**SPECIFICATIONS**  
**ZODIAC XL SLSA**

|                               |             |
|-------------------------------|-------------|
| WING SPAN .....               | .27 FT.     |
| WING AREA .....               | 134 SQ. FT. |
| LENGTH .....                  | 20 FT.      |
| ENGINE .....                  | 100BHP      |
| PROPELLER (Fixed Pitch) ..... | 58 IN.      |
| WING ASPECT RATIO .....       | 5.4         |
| GROSS WEIGHT .....            | 1320 lbs    |

**SECTION 2**  
**ZODIAC XL-SLSA WITH 0-200 ENGINE**

---

|  |   |                      |
|--|---|----------------------|
| <b>ENGINE</b>                                      | - 4 Cylinders Horizontally Opposed - Air Cooled |                      |
| Engine Manufacturer                                |   | Teledyne Continental |
| Engine Model Number                                |   | 0-200-A (82)         |
| Rated Horsepower                                   |   | 100                  |
| RPM Rating, standard atmosphere Max.<br>continuous |   | 2750                 |
| Recommended cruising RPM                           |   | 2500                 |
| Compression Ratio                                  |   | 7.0:1                |

|                                       |                    |  |              |
|---------------------------------------|--------------------|--|--------------|
| <b>FUEL - Standard</b>                |                    |  |              |
| Fuel Capacity,                        | left + right tanks |  | 30 U.S. gal. |
| Usable Fuel (U.S. gal) (total)        | left + right tanks |  | 28 U.S. gal  |
| Minimum fuel grade. See engine manual |                    |  | 80/87        |

|                         |  |  |          |
|-------------------------|--|--|----------|
| <b>OIL</b>              |  |  |          |
| Oil sump. capacity      |  |  | 6 Quarts |
| Oil grade - Below 40° F |  |  | SAE 20   |
| - Above 40° F.          |  |  | SAE 40   |

**Note: See engine Operators Manual on above for more details.**

|                                |  |  |           |
|--------------------------------|--|--|-----------|
| <b>PROPELLER - Fixed Pitch</b> |  |  |           |
| Propeller Manufacturer         |  |  | Sensenich |
| Model                          |  |  | W68ZK-56  |
| Number of Blades               |  |  | 2         |
| Propeller Diameter (inches)    |  |  | 68        |

|   |  |  |          |
|---|--|--|----------|
| <b>OPERATING WEIGHTS</b>                |  |  |          |
| Maximum Takeoff Weight (lbs)            |  |  | 1320 lbs |
| Maximum Landing Weight (lbs)            |  |  | 1320 lbs |
| Maximum Weights in Baggage Compartment. |  |  | 40 lbs   |
| See weight and balance                  |  |  |          |

**SYMBOLS, ABBREVIATIONS AND TERMINOLOGY**

The following definitions are of symbols, abbreviations and terminology used throughout the handbook and those which may be of added operational significance to the pilot.

- General Airspeed Terminology and Symbols

|                       |   |
|-----------------------|---|
| <b>BHP</b>            | Brake horsepower (= rated horsepower of the engine)   |
| <b>CAS</b>            | Calibrated Airspeed means the indicated speed of an aircraft, corrected for position and instrument error. Calibrated airspeed is equal to true airspeed in standard atmosphere at sea level. |
| <b>GPH</b>            | Fuel consumption in Gallons (U.S.) per Hour.  |
| <b>KCAS</b>           | Calibrated Airspeed expressed in "Knots".   |
| <b>C.G.</b>           | Centre of Gravity.  |
| <b>IAS</b>            | Indicated Airspeed is the speed of an aircraft as shown on the airspeed indicator.  |
| <b>KIAS</b>           | Indicated Airspeed expressed in "Knots".  |
| <b>L</b>              | Left  |
| <b>R</b>              | Right   |
| <b>RPM</b>            | Revolutions per minute.   |
| <b>S.L.</b>           | Sea Level   |
| <b>TAS</b>            | True Airspeed is the airspeed of an airplane relative to undisturbed air which is the CAS corrected for altitude and temperature.   |
| <b>V</b>              | Speed.  |
| <b>V<sub>A</sub></b>  | Maneuvering Speed is the maximum speed at which application of full available aerodynamic control will not overstress the airplane.   |
| <b>V<sub>FE</sub></b> | Maximum Flap Extended Speed is the highest speed permissible with wing flaps partially or fully extended.   |

**SECTION 2**  
**ZODIAC XL-SLSA WITH 0-200 ENGINE**

---

General Airspeed Terminology and Symbols (continued)

|                       |  |
|-----------------------|--|
| <b>V<sub>NE</sub></b> | Never Exceed Speed is the speed limit that may not be exceeded at any time.  |
| <b>V<sub>C</sub></b>  | Maximum Structural Cruising Speed is the speed that should not be exceeded except in smooth air and only with caution.       |
| <b>V<sub>S</sub></b>  | Stalling Speed or the minimum steady flight speed at which the airplane is controllable (flaps up).                          |
| <b>V<sub>SO</sub></b> | Stalling Speed at which the airplane is controllable in the landing configuration.   |
| <b>V<sub>X</sub></b>  | Best Angle-of-Climb Speed is the air speed which delivers the greatest gain of altitude in the shortest horizontal distance. |
| <b>V<sub>Y</sub></b>  | Best Rate-of-Climb Speed is the air speed which delivers the greatest gain in altitude in the shortest time.                 |

**SECTION 2**  
**ZODIAC XL-SLSA WITH 0-200 ENGINE**

---

- Meteorological Terminology

|                                    |   |
|------------------------------------|---|
| <b>ISA</b>                         | International Standard Atmosphere in which:<br>The air is a dry perfect gas;<br>The temperature at sea level is 15° Celsius (59° Fahrenheit);<br>The pressure at sea level is 29.92 inches hg. (1013 mb);<br>The temperature gradient from sea level up, is: - 1.98° C per 1000 ft or - 6.5° C per 1000 meter, or -3.57° F per 1000 ft. |
| <b>OAT</b>                         | Outside Air Temperature is the free air static temperature, obtained either from inflight temperature indications or ground meteorological sources, adjusted for instrument error.  |
| <b>Indicated Pressure Altitude</b> | The number actually read from an altimeter when the barometric subscale has been set to 29.92 inches of mercury (1013 millibars).   |
| <b>Pressure Altitude</b>           | Altitude measured from standard sea-level pressure (29.92 in. Hg) by a pressure or barometric altimeter. It is the indicated pressure altitude corrected for position and instrument error. In this Pilot Operating Handbook, altimeter instrument errors are assumed to be zero.   |
| <b>Station Pressure</b>            | Actual atmospheric pressure at field elevation.   |
| <b>Wind</b>                        | The wind velocities recorded as variables on the charts of this Pilot Operating Handbook are to be understood as the headwind or tailwind components of the reported winds.   |

- Units

**Speed:** Kts (Knots) = 1.15 mph (miles per hour)

**Pressure:** PSI = Pounds per Square Inch  
in Hg = inches of Mercury  
mb = millibar

**Distances:** in. = inches = 25.4 millimeters  
ft = foot (feet) = .305 meters

**Weights:** Kg = kilograms = 2.2 lbs = 2.2 pounds

**SECTION 2**  
**ZODIAC XL-SLSA WITH 0-200 ENGINE**

---

- Power Terminology

|                                 |   |
|---------------------------------|---|
| <b>Takeoff Power</b>            | Maximum power permissible for takeoff.                |
| <b>Maximum Continuous Power</b> | Maximum power permissible continuously during flight. |
| <b>Maximum Climb Power</b>      | Maximum power permissible during climb.               |
| <b>Maximum Cruise Power</b>     | Maximum power permissible during cruise.              |

- Engine Instruments

|                  |                     |
|------------------|---------------------|
| <b>CHT Gauge</b> | Cylinder Head Temp. |
|------------------|---------------------|

- Airplane Performance and Flight Planning Terminology

|  |   |
|--|---|
| <b>Climb Gradient</b>                  | The demonstrated ratio of the change in height during a portion of a climb, to the horizontal distance traversed in the same time interval.   |
| <b>Demonstrated Crosswind Velocity</b> | The demonstrated crosswind velocity is the velocity of the 90 deg. crosswind component for which adequate control of the airplane during takeoff and landing was actually demonstrated. |

**SECTION 2**  
**ZODIAC XL-SLSA WITH 0-200 ENGINE**

---

- Weight and Balance Terminology

|                                 |   |
|---------------------------------|---|
| <b>Reference Datum</b>          | An imaginary vertical plane from which all horizontal distances are measured for balance purposes: wing leading edge at rib #3  |
| <b>Station</b>                  | A location along the airplane fuselage centerline given in terms of distance from the Reference Datum.  |
| <b>Position or Arm</b>          | The horizontal distance from the Reference datum to the center of gravity (C.G.) of an item parallel to fuselage centerline.  |
| <b>Moment</b>                   | The product of the weight of an item multiplied by its arm. (Moment divided by a constant is used to simplify balance calculations by reducing the number of digits.)       |
| <b>Center of Gravity (C.G.)</b> | The point at which an airplane would balance if suspended. Its distance from the reference datum is found by dividing the total moment by the total weight of the airplane. |
| <b>C.G. Arm</b>                 | The arm obtained by adding the airplane's individual moments and dividing the sum by the total weight.  |
| <b>C.G. Limits</b>              | The extreme center of gravity locations within which the airplane must be operated at a given weight.   |
| <b>Usable Fuel</b>              | Fuel available for flight planning.   |
| <b>Unusable Fuel</b>            | Fuel remaining after a runout test has been completed in accordance with the design standards.  |
| <b>Standard Empty Weight</b>    | Weight of a standard airplane including unusable fuel, full operating fluids and full oil.  |
| <b>Empty Weight</b>             | Standard empty weight plus optional equipment.  |
| <b>Payload</b>                  | Weight of occupants, fuel and baggage.  |
| <b>Useful Load</b>              | Difference between takeoff weight, and empty weight.  |
| <b>Maximum Takeoff Weight</b>   | Maximum approved weight.  |

**SECTION 3**  
**OPERATING LIMITATIONS**

SAMPLE



**SECTION 3**  
**ZODIAC XL-SLSA WITH 0-200 ENGINE**

---

**SECTION 3**

**OPERATING LIMITATIONS**

**GENERAL**

This section includes operating limitations and instrument markings necessary for safe operation of the airplane, its engine, standard systems and standard equipment.

**AIRSPEED LIMITATIONS**

| <b>SPEED</b>   | <b>KCAS<br/>(Knots)</b> | <b>KIAS<br/>(Knots)</b> | <b>REMARKS</b>  |
|--|-------------------------|-------------------------|---|
| V <sub>S</sub> Maximum Stall Speed at Maximum takeoff weight – FLAPS UP    | 43                      |                         |   |
| V <sub>SO</sub> Maximum Stall Speed at Maximum takeoff weight – FLAPS DOWN | 38                      |                         |   |
| V <sub>FE</sub> Maximum Flap Extended Speed                                | 70                      |                         | Do not exceed this speed with flaps extended.                             |
| V <sub>A</sub> Design Maneuvering Speed                                    | 90                      |                         | Do not make full or abrupt control movements above this speed.            |
| V <sub>NE</sub> Never Exceed Speed   | 140                     |                         | Do not exceed this speed in any operation.                                |
| V <sub>C</sub> Design Cruising Speed                                       | 108                     |                         | Do not exceed this speed except in smooth air and then only with caution. |

**CROSSWIND AND WIND LIMITATION:** 20 Kts

**SEVICE CEILING:** 15,000 feet

**LOAD FACTORS (LIMIT):**

Flap up: Positive + 4 g  
 Negative - 2 g  
 (Ultimate is 1.5 times limit)

Flap extended: Positive + 2 g  
 Negative - 0 g

**PROHIBITED MANEUVERS:**

Intentional spins prohibited.  
 Aerobatics prohibited.

**WARNING**  
 Exceeding the maximum load factors will lead to an overstressing of the airplane.

**TYPES OF OPERATIONS**

The airplane is approved for the following operations when equipped in accordance with the prevailing regulations.

Day V.F.R.  
 Flight in known or forecast icing conditions is prohibited.

**SECTION 4**

**WEIGHT AND BALANCE INFORMATION**

**SAMPLE**

**SECTION 4**

**WEIGHT AND BALANCE**

**4.1 GENERAL**

In order to achieve the performance and flying characteristics which are designed into the airplane, it must be flown with the weight and center of gravity (C.G.) position within the approved operating range (envelope). Although the airplane offers flexibility of loading, the pilot must ensure that the airplane is loaded within the envelope before attempting to take off.

Mis-loading carries consequences for any aircraft. An overloaded airplane will not take off, climb or cruise properly. The heavier the airplane is loaded, the less climb performance it will have.

Center of gravity is a determining factor in flight characteristics. If the C.G. is too far forward in any airplane, it will be difficult to rotate for takeoff or landing and the nose gear overstressed at landings! If the C.G. is aft of the approved limit, the airplane may rotate prematurely on takeoff or tend to pitch up or down; the aircraft will be unstable in pitch. This can lead to inadvertent stalls and even spins; stall and spin recovery may be impossible in an improperly loaded airplane.

A properly loaded airplane, however, will perform as intended. Before the airplane is delivered, it is weighed, and the corresponding empty weight and C.G. location is computed (the empty weight consists of the standard empty weight of the airplane plus the optional equipment). Using the empty weight and C.G. location, pilots can easily determine the weight and C.G. position for the loaded airplane by computing the total weight and moment and then determining whether they are within the approved envelope.

The empty weight and C.G. location are recorded in the Weight and Balance Record Form. The current values should always be used. Whenever new equipment is added or any modification work is done, a new empty weight and C.G. position should be determined and recorded. The owner must make sure that this is done.

To determine a new empty-weight C of G, the airplane must first be weighed and then the new C of G position must be calculated.

To determine the C of G for the loaded airplane, loaded weight and balance calculations must be performed before flight.



**SECTION 4**  
**ZODIAC XL-SLSA WITH 0-200 ENGINE**

**ZODIAC CH 601 XL**  
**WEIGHT & BALANCE REPORT**  
 Forward & Aft C.G. Check

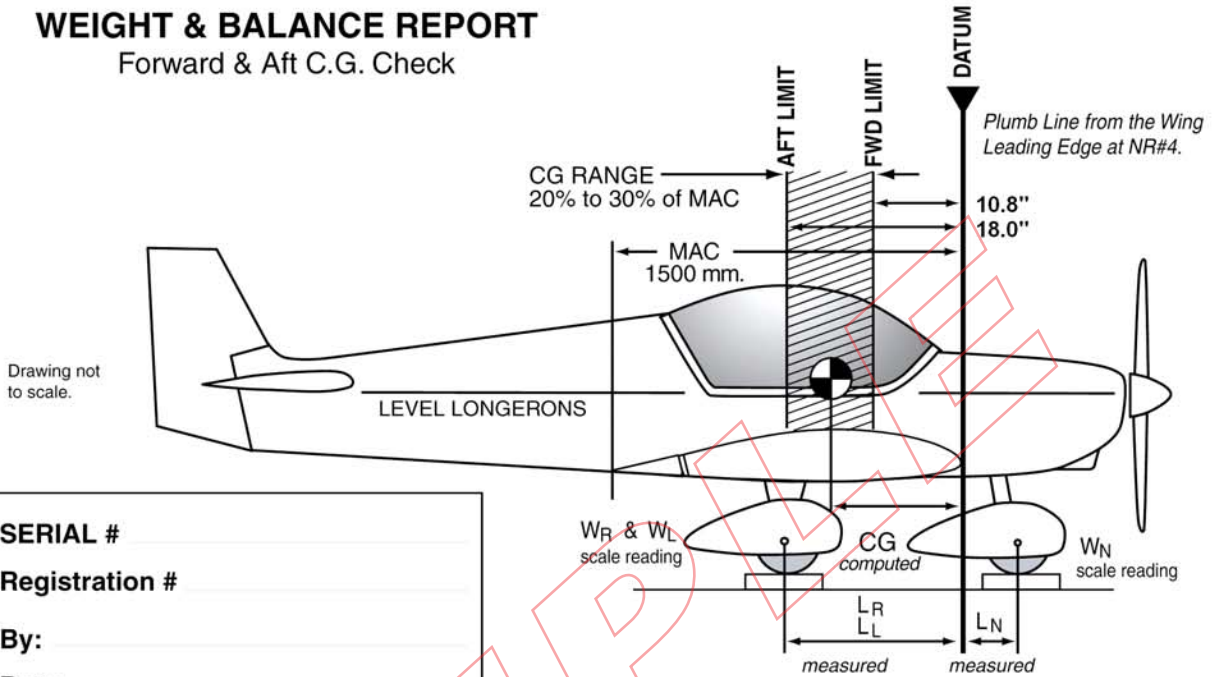

**SERIAL #** \_\_\_\_\_  
**Registration #** \_\_\_\_\_  
**By:** \_\_\_\_\_  
**Date:** \_\_\_\_\_

| ITEM   | WEIGHT (pounds)  | ARM (mm.)                        | MOMENT                     |
|--|------------------|----------------------------------|----------------------------|
| <b>AIRCRAFT EMPTY CG</b><br>RIGHT MAIN WHEEL | $W_R =$          | $L_R =$                          | $W_R \times L_R$           |
| LEFT MAIN WHEEL                              | $W_L =$          | $L_L =$                          |                            |
| NOSE WHEEL                                   | $W_N =$          | $L_N = -$<br><i>negative arm</i> | $-$<br><i>negative</i>     |
| COMPUTED CG<br>EMPTY                         | Empty<br>Weight: | CG=<br><i>Arm to Datum</i>       | <br><i>Aircraft Moment</i> |

**Forward Check:**  
 Add to the empty weight & aircraft moment items located forward of the computed empty CG (ie. Fuel) plus the pilot.

|  |                  | MOMENT - Forward | MOMENT - Rear |
|--|------------------|------------------|---------------|
| PILOT  |                  | 28"              |               |
| PASSENGER                                      |                  | 28"              |               |
| BAGGAGE  |                  | 63"              |               |
| FUEL: L.E. WING TANKS<br>L & R: ____ Gal. each |                  | 7"               |               |
| <b>TOTAL</b>                                   | $W_F =$          |                  | $M_F =$       |
|  | $W_R =$          |                  | $M_R =$       |
| Gross Weight:                                  | Take-Off Weight: | CGFRD =          | CGAFT =       |

CG Range: From 10.8" to 18"

$$\text{Center of Gravity (CG)} = \frac{\text{Total Moment}}{\text{Total Weight}}$$



## SECTION 4

### ZODIAC XL-SLSA WITH 0-200 ENGINE

---

#### 4.3 AIRPLANE WEIGHING PROCEDURE

The removal or addition of equipment or airplane modifications may affect basic empty weight and center of gravity. The following is a weighing procedure to determine this empty weight and center of gravity location:

##### Preparation

- (1) Be certain that all items checked in the airplane equipment list are installed in the proper location in the airplane.
- (2) Remove dirt, grease, moisture, foreign items such as rags and tools from the airplane before weighing.
- (3) Defuel airplane: Open the fuel drain until all fuel is drained.

##### CAUTION

Whenever the fuel system is completely drained and fuel is replenished, it will be necessary to run the engine for a minimum of three minutes above idle (on each tank) to insure no air remains in the fuel supply lines.

- (4) Fill with oil to full capacity.
- (5) Flaps fully up and all control surfaces in the neutral position. Canopy and access panels closed.
- (6) Place the airplane on weighing scales inside a closed building to prevent errors in scale readings due to wind, and block the main gear.

##### Leveling

The horizontal reference is the upper fuselage longeron (at canopy sill).

Level airplane, by raising or lowering the nose wheel (lower by removing air from nose wheel tire), to center bubble on level placed on doorsill.

##### After Weighing the Airplane

Re-inflate the nose wheel tire if required (28-30 PSI)

Use table of weight & Balance report and fill in table weight & Balance record.

**SECTION 4**  
**ZODIAC XL-SLSA WITH 0-200 ENGINE**

---

**Weight and Balance Calculations for Flight**

Before each flight, the weight and balance of the loaded airplane should be calculated as follows and checked to fit inside the approved limits.

**Following tables may be used:**

- 1) Obtain the Empty weight and C.G. position  
 Use the latest figures from the Weight and Balance record.
- 2) Use the applicable values shown in following table listing the **fuel** in each wing tank.

**Fuel in each wing tank**

| Gauge<br>each tank | Quantity | Weight | Position | Moment     |
|--------------------|----------|--------|----------|------------|
|                    | US gal   | lbs    | inches   | lbs.inches |
| 1                  | 15       | 90     | 7"       | 630        |
| 1/2                | 7        | 42     | 7"       | 295        |
| 0                  | 0        | ----   | ----     | ----       |

**Note:** 1 U.S. gal fuel = 6 lbs.

- 3) Use the applicable values shown in following table for the occupants.

| Weight | Position<br>* | Moment*     |
|--------|---------------|-------------|
| lbs    | inches        | lbs. inches |
| 100    | 28            | 2,800       |
| 150    | 28            | 4,200       |
| 200    | 28            | 5,600       |
| 250    | 28            | 7,000       |
| 300    | 28            | 8,400       |
| 350    | 28            | 9,800       |
| 400    | 28            | 11,200      |

\* **Note:** The exact position of the occupants depends on their geometry (!) and the seat adjustment (use of cushions).

Above table gives only an average; more accurate results will be obtained by using actual figures.

**Note:** Measure the Position with tape measure from the DATUM line (front of wing leading edge) and enter into tables for more accurate results.



**SECTION 4**  
**ZODIAC XL-SLSA WITH 0-200 ENGINE**

4) Use the applicable values shown in the following table for fuselage baggage.

**FUSELAGE BAGGAGE (behind seat – top) MAXIMUM 40 LBS.**

| <b>Weight</b> | <b>Position*</b> | <b>Moment*</b>    |
|---------------|------------------|-------------------|
| <b>lbs</b>    | <b>inches</b>    | <b>lbs.inches</b> |
| 10            | 63               | 630               |
| 20            | 63               | 1,260             |
| 30            | 63               | 1,890             |
| 40            | 63               | 2,520             |

**BAGGAGE WING LOCKER LEFT**

**BAGGAGE WING LOCKER RIGHT**

| <b>Weight</b> | <b>Position*</b> | <b>Moment*</b>    | <b>Weight</b> | <b>Position*</b> | <b>Moment*</b>    |
|---------------|------------------|-------------------|---------------|------------------|-------------------|
| <b>lbs</b>    | <b>inches</b>    | <b>lbs.inches</b> | <b>lbs</b>    | <b>inches</b>    | <b>lbs.inches</b> |
| 10            | 26               | 260               | 10            | 26               | 260               |
| 20            | 26               | 520               | 20            | 26               | 520               |
| 30            | 26               | 780               | 30            | 26               | 780               |
| 40            | 26               | 1,040             | 40            | 26               | 1,040             |

5) Enter all the applicable values obtained from weight & balance report and above tables into the appropriate blocks below and perform the necessary calculations.

|                                | <b>Weight<br/>kg or lbs</b> | <b>Position<br/>inches</b> | <b>Moment<br/>lbs.inches</b> |
|--------------------------------|-----------------------------|----------------------------|------------------------------|
| 1) Empty                       |                             |                            |                              |
| 2) Fuel                        |                             |                            |                              |
| 3) Occupant                    |                             |                            |                              |
| 4) Baggage Fuselage            |                             |                            |                              |
| 45 Baggage Wings               |                             |                            |                              |
| <b>Total (add the columns)</b> | <b>W=</b>                   |                            | <b>M=</b>                    |

Loaded Aircraft weight is  $W = \text{_____}$  (lbs)

Loaded C.G. position is  $x = M/W = \text{_____} = \text{_____}$  (x in inches)

Check that both W and x fall within the limits.

**Note:** You may also want to repeat the above calculation corresponding to the aircraft at the end of the trip, which means with the fuel level as expected at destination.

**Note:** Measure the Position with tape measure from the DATUM line (front of wing leading edge) and enter into tables for more accurate results.

**SECTION 4**  
**ZODIAC XL-SLSA WITH 0-200 ENGINE**

**WEIGHT & BALANCE CHART**

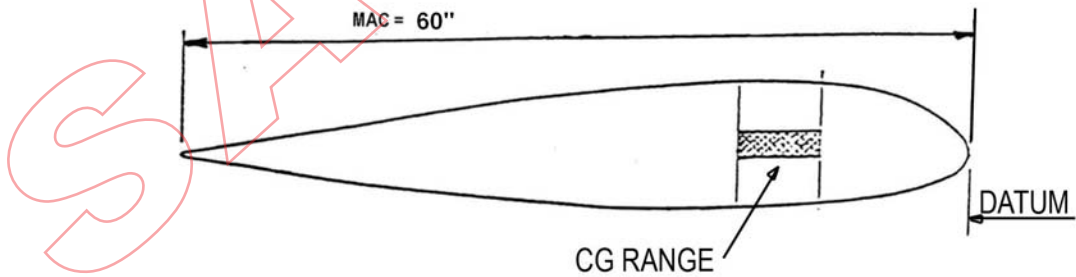
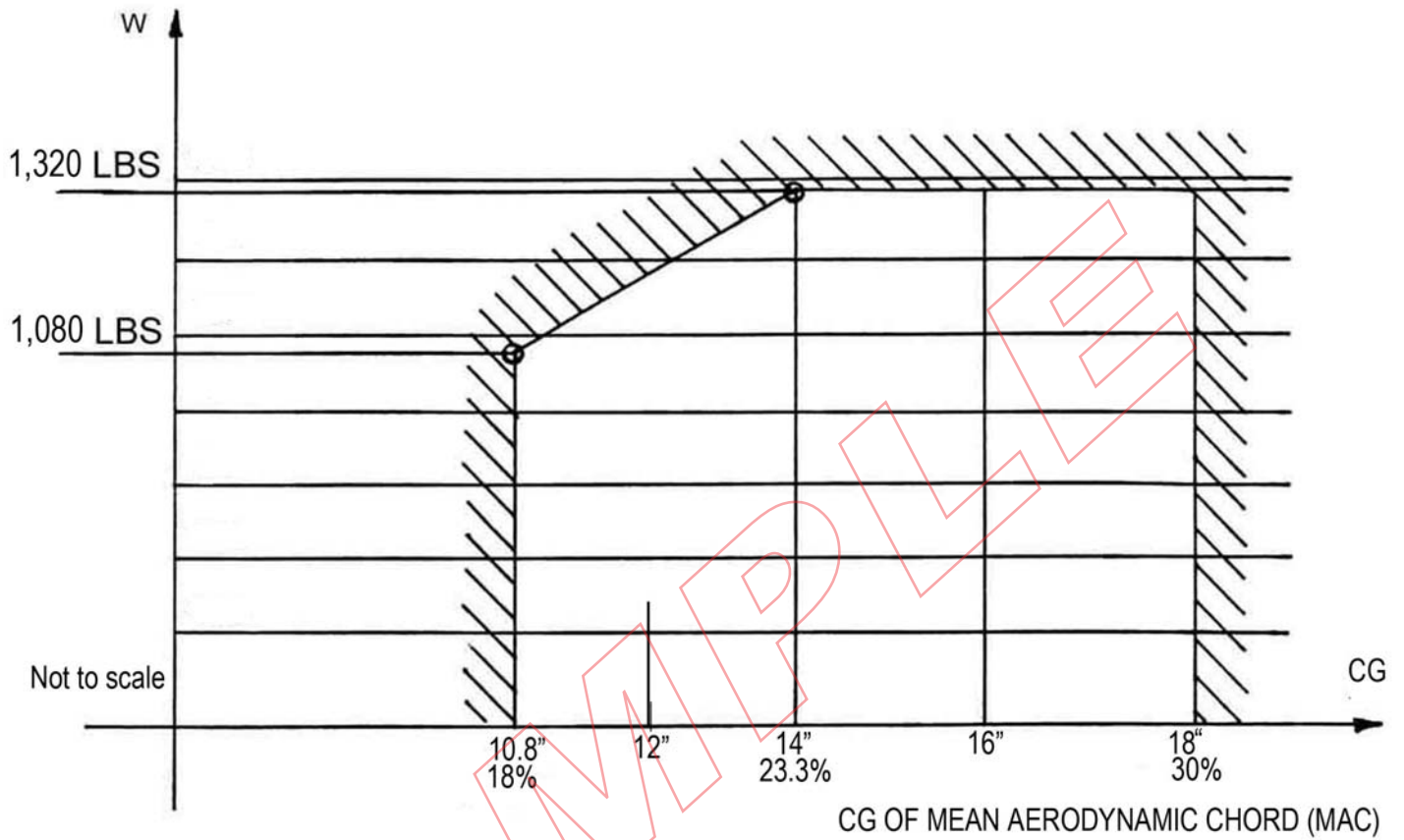

Not to scale

**SECTION 5**  
**PERFORMANCE**

SAMPLE

**SECTION 5**  
**PERFORMANCE**

**GENERAL**

All of the required performance information applicable to this aircraft is provided by this section.

SAMPLE

**SECTION 5**  
**ZODIAC XL-SLSA WITH 0-200 ENGINE**

---

**TAKE OFF ROLL:**

From **hard surface**, full power at brake release, flaps up

|            | Std. -30 deg. F. | Std. | Std +30 deg. F. | Temperature |
|------------|------------------|------|-----------------|-------------|
| S.L. = 0   | 450              | 490  | 550             |             |
| 3,000 feet | 600              | 660  | 740             |             |
| 6,000 feet | 800              | 880  | 970             |             |
| Altitude   |                  |      |                 |             |

Above values are in feet

On grass, increase above values by 20% approximately.

**TAKE OFF ROLL + CLIMB TO CLEAR 50 FT. OBSTACLE AT 60 KCAS:**

From **hard surface**, full power at brake release, flaps up

|            | Std. -30 deg. F. | Std. | Std +30 deg. F. | Temperature |
|------------|------------------|------|-----------------|-------------|
| S.L. = 0   | 740              | 820  | 900             |             |
| 3,000 feet | 900              | 1000 | 1100            |             |
| 6,000 feet | 1210             | 1350 | 1480            |             |
| Altitude   |                  |      |                 |             |

Above values are in feet

On grass, increase above values by 20% approximately.

Above values are decreased by 25% for 10 kts headwind and 40% for 20 kts headwind.

**LANDING ROLL:**

|            | Std. -30 deg. F. | Std. | Std +30 deg. F. | Temperature |
|------------|------------------|------|-----------------|-------------|
| S.L. = 0   | 450              | 490  | 550             |             |
| 3,000 feet | 510              | 560  | 620             |             |
| 6,000 feet | 570              | 630  | 700             |             |
| Altitude   |                  |      |                 |             |

Above values are in feet

**SECTION 5**  
**ZODIAC XL-SLSA WITH 0-200 ENGINE**

---

**LANDING DISTANCE:**

Landing distance from 50 ft. height, flaps down, throttle idle, approach speed = 60 KCAS

|            | Std. -30 deg. F. | Std. | Std +30 deg. F. | Temperature |
|------------|------------------|------|-----------------|-------------|
| S.L. = 0   | 670              | 750  | 820             |             |
| 3,000 feet | 740              | 820  | 900             |             |
| 6,000 feet | 800              | 900  | 990             |             |
| Altitude   |                  |      |                 |             |

**RATE OF CLIMB:**

1320 lbs, flaps up and full throttle at  $V_y = 60$  KCAS

|            | Std. -30 deg. F. | Std. | Std +30 deg. F. | Temperature |
|------------|------------------|------|-----------------|-------------|
| S.L. = 0   | 930              | 900  | 860             |             |
| 3,000 feet | 780              | 750  | 710             |             |
| 6,000 feet | 630              | 600  | 560             |             |
| 9,000 feet | 480              | 450  | 420             |             |
| Altitude   |                  |      |                 |             |

**CRUISE SPEEDS & RPM**

Cruise speeds and RMP in standard atmosphere and 75% power (above 7,000 ft. the power is less)

|                            | RPM  | IAS - kts | CAS - kts | Range - MPH |
|----------------------------|------|-----------|-----------|-------------|
| S.L. = 0                   | 2500 |           | 103       | 410         |
| 3,000 feet                 | 2600 |           | 108       | 440         |
| 6,000 feet                 | 2700 |           | 112       | 450         |
| 9,000 feet (less than 75%) | 2750 |           | 102       | 420         |
| Altitude                   |      |           |           |             |

At 75% power, the **fuel consumption** is about 5 gal/hr.

With  $2 \times 14 = 28$  gal. fuel tanks full, the endurance is about 6.8 hours (unusable fuel is 1 gal. each tank).

**Note:** Reducing the power will reduce the speed and fuel consumption and slightly increase the range.

**BEST ANGLE OF CLIMB:**

Best angle of climb  $V_x$  is      **KIAS**, (58 KCAS)

Flaps up, full power at 1320 lbs.

**SECTION 5**  
**ZODIAC XL-SLSA WITH 0-200 ENGINE**

---

**CROSSWIND:**

The demonstrated takeoff and landing crosswind component is 20 kts.

**SERVICE CEILING:**

Where rate of climb is 100 FPM in standard atmosphere: 15,000 feet.

**AIRSPEED CALIBRATION KTS – FLAPS UP**

|             |           |           |           |           |            |            |            |
|-------------|-----------|-----------|-----------|-----------|------------|------------|------------|
| <b>KIAS</b> | <b>35</b> | <b>50</b> | <b>70</b> | <b>90</b> | <b>110</b> | <b>130</b> | <b>140</b> |
| <b>KCAS</b> |           |           |           |           |            |            |            |

**AIRSPEED CALIBRATION KTS – FLAPS DOWN**

|             |           |           |           |           |
|-------------|-----------|-----------|-----------|-----------|
| <b>KIAS</b> | <b>30</b> | <b>40</b> | <b>50</b> | <b>60</b> |
| <b>KCAS</b> |           |           |           |           |

**Above calibration is specific to this aircraft.**

**NOTE:**

**KCAS** Calibrated Airspeed means the indicated speed of an aircraft, corrected for position and instrument error. Calibrated airspeed is equal to true airspeed in standard atmosphere at sea level. Calibrated Airspeed expressed in "Knots".

**KIAS** Indicated Airspeed is the speed of an aircraft as shown on the airspeed indicator. Indicated Airspeed expressed in "Knots".

**NOTE: If KIAS does not seem correct, see Maintenance Manual Appendix 1, AIRSPEED IN-FLIGHT ACCURACY**

**STALL SPEEDS AT 1,320 lbs. (Max. take off weight)**

Flaps up  $V_s$  = \_\_\_\_ **KIAS**, 43 KCAS

Flaps down  $V_{so}$  = \_\_\_\_ **KIAS**, 38 KCAS

**SECTION 6**  
**EMERGENCY PROCEDURES**

SAMPLE



**SECTION 6**

**EMERGENCY PROCEDURES**

**GENERAL**

The recommended procedures for coping with various types of emergencies and critical situations are provided by this section.

The first portion of this section consists of an abbreviated emergency check list which supplies an action sequence for critical situations with little emphasis on the operation of the systems.

The remainder of the section is devoted to amplified emergency procedures containing additional information to provide the pilot with a more complete understanding of the procedures.

These procedures are suggested as the best course of action for coping with the particular condition described, but are not a substitute for sound judgment and common sense. Pilots should familiarize themselves with the procedures given in this section and be prepared to take appropriate action should an emergency arise. See Engine Operators Manual for more information.

SAMPLE

**SECTION 6**  
**ZODIAC XL-SLSA WITH 0-200 ENGINE**

---

**EMERGENCY PROCEDURES CHECK LIST**

**ENGINE FIRE DURING START**

Starter . . . . . continue cranking  
( If engine starts)  
Power . . . . . 1700 RPM momentarily  
Engine . . . SHUTDOWN and inspect for damage  
(If engine fails to start)  
Ignition . . . . . OFF  
Master Switch . . . . . OFF  
Mixture . . . . . IDLE CUT OFF  
Fuel . . . . . OFF  
(abandon aircraft and fight fire)

**ENGINE FAILURE DURING TAKEOFF**

Throttle . . . . . IDLE  
Brakes . . . . . APPLY  
Wing Flaps . . . . . UP  
Mixture . . . . . IDLE CUT-OFF  
Ignition Switch . . . . . OFF  
Master Switch . . . . . OFF

**ENGINE FAILURE AFTER TAKEOFF**

Airspeed . . . . . **\_\_\_ KIAS** (60 KCAS)  
Mixture . . . . . IDLE CUT-OFF  
Fuel Selector . . . . . OFF  
Ignition Switch . . . . . OFF  
Wing Flaps . . . . . AS REQUIRED  
Master Switch . . . . . OFF

**ENGINE FAILURE IN FLIGHT**

(Restart Procedure)

Airspeed . . . . . **\_\_\_ KIAS** (60 KCAS)  
Fuel Selector . . . . . ON  
Aux Fuel Pump . . . . . ON  
Mixture . . . . . RICH  
Mag. Switch . . . . . BOTH  
Carburetor Heat . . . . . ON  
Gauges . . . . . Check for source of power loss  
See engine manual

**POWER OFF LANDING**

Touchdowns should normally be made at lowest possible airspeed with full flaps.  
When committed to landing:  
Ignition . . . . . **OFF**  
Master Switch . . . . . **OFF**  
Fuel selector . . . . . **OFF**  
Mixture . . . . . **IDLE CUT OFF**  
Seat belt and harness . . . . . **Secure**

**SECTION 6**  
**ZODIAC XL-SLSA WITH 0-200 ENGINE**

---

**PRECAUTIONARY LANDING WITH ENGINE POWER**

Seats, Seat Belts, Shoulder Harnesses ..**SECURE**  
Airspeed . .      **KIAS** (60 KCAS) (**flaps UP**)  
                       **KIAS** (60 KCAS) (**flaps down**)  
Mixture . . . . . **RICH**  
Fuel Selector. . . . . **ON**  
Ignition Switch . . . . . **ON**  
Wing Flaps . . . . . **as required**  
Master Switch . . . . . **ON**  
Touchdown . . . . . **slightly tail low**  
Brakes . . . . . **as required**

**FIRE IN FLIGHT**

Source of fire . . . . . **check**

**Electrical fire (smoke in cabin):**

Master switch and Alt. Field. . . . . **OFF**  
Vents . . . . . **OPEN**  
Cabin heat . . . . . **OFF**  
Fire Extinguisher . . . . . If and as required  
Land as soon as practical.

**Engine fire:**

Cabin Heat . . . . . **OFF**  
Fuel selector . . . . . **OFF**  
Throttle . . . . . **CLOSED**  
Mixture . . . . . **IDLE CUT-OFF**  
Auxiliary fuel pump . . . . . **OFF**  
Proceed with **POWER OFF LANDING** procedure

**LOSS OF OIL PRESSURE**

Reduce power.  
Prepare for power off landing, and land as soon as practical.

**LOSS OF FUEL PRESSURE**

Auxiliary fuel pump . . . . . **ON**  
Fuel selector . . . . . **check "ON"**  
Land at nearest airport and investigate problem.

**HIGH OIL TEMPERATURE**

Land at nearest airport and investigate the problem. Prepare for power off landing.

**ALTERNATOR FAILURE**

Verify failure  
Reduce electrical load as much as possible.  
Circuit breakers . . . . . **check**  
Alt. switch. . . . . **OFF** (for 1 second), then **ON**  
If no input Alt field. . . . . **OFF**  
Reduce electrical load and land as soon as practical.

**SPIN RECOVERY**

Rudder . . . . . Full opposite to spin direction.  
Ailerons . . . . . Full opposite to spin direction.  
Pitch . . . . . Full forward.  
When rotation stops, centralize rudder and ease control back to gently recover from dive.

careful not to exceed the speed and g load limits.  
If flaps were extended: retract them during recovery. Observe flap limit speed, if flaps are down.

**ENGINE ROUGHNESS**

Carburetor heat . . . . . **ON**  
Mixture . . . . . adjust for max. smoothness  
Auxiliary fuel pump . . . . . **ON**  
Fuel selector . . . . . **check open**  
Engine gauges . . . . . **check**  
Magneto switch . . . . . **"BOTH"**

If operation is satisfactory on either one, continue on that magneto at reduced power and full **"RICH"** mixture to first airport.  
Prepare for power off landing.  
Also seen Engine Operates Manual

**SECTION 6**  
**ZODIAC XL-SLSA WITH 0-200 ENGINE**

---

**ICING**

**Inadvertent Icing Encounter**

Ensure Pitot heat (IFR option) is **ON**

Turn back or change altitude to obtain an outside air temperature that is less conducive to icing.

Pull cabin heat control full out to obtain maximum air temperature. IFR airframe has small windshield defroster when cabin heat is pulled.

Open the throttle to increase engine speed and minimize ice build-up on propeller blades.

Apply carburetor heat as required. Lean the mixture for maximum RPM, if carburetor heat is used continuously.

Plan a landing at the nearest airport. With an extremely rapid ice build-up, select a suitable "off airport" landing site.

With ice accumulation on the wing leading edges, be prepared for significantly higher stall speed.

Leave wing flaps retracted. With a severe ice build-up on the horizontal tail, the change in wing wake airflow direction caused by wing flap extension could result in a loss of elevator effectiveness.

**ELECTRICAL POWER SUPPLY SYSTEM MALFUNCTIONS**

**Ammeter Shows Excessive Rate of Charge (Full scale deflection)**

Alternator . . . . . **OFF**  
 Alternator Circuit Breaker . . . . . **OFF**  
 Nonessential Electrical Equipment . . . . . **OFF**  
 Flight . . . . . **Terminate** as soon as possible

OR (option)

Master Switch . . . . . **OFF**  
 Nonessential Electrical Equipment . . . . . **OFF**  
 Avionics master switch . . . . . **ON**

**Ammeter Indicates Discharge**

**NOTE**

Radios . . . . . **OFF**  
 Alternator Circuit Breaker . . . . . **CHECK ON**  
 Master Switch . . . . . **OFF**  
 Master Switch . . . . . **ON**  
 Radios . . . . . **ON**

**If Ammeter Continues Indicating Discharge**

Alternator . . . . . **OFF**  
 Nonessential Radio and Elect. Equipment **OFF**  
 Flight . . . . . **Terminate** as soon as possible

**ELECTRIC FLAP**

Should the flaps become inoperative, the flight may be continued safely provided following is kept in mind:

**Flaps Down:** Do not exceed      **KIAS**  
 (80 KCAS)

Caution: The rate of climb is reduced.  
 Monitor the engine oil temperature.

**Flaps Up:** Approach at      **KIAS** (60 KCAS)

Caution: Be prepared for a longer landing distance.

**ELECTRIC TRIM**

In case of complete electric failure (battery and alternator) or trim runaway; the pilot will no longer be able to neutralize the pitch control forces. They may become quite heavy. Adjust speed and power to minimize the forces on the control and be prepared to have to exercise **unusually high pull or push** especially during landing.

**LIGHTNING STRIKE**

In case of a lightning strike, land at the nearest airport to investigate the damage.

**SECTION 6**  
**ZODIAC XL-SLSA WITH 0-200 ENGINE**

---

**AMPLIFIED EMERGENCY PROCEDURES (GENERAL)**

The following paragraphs are presented to supply additional information for the purpose of providing the pilot with a more complete understanding of the recommended course of action and probable cause of an emergency situation.

**ENGINE FIRE DURING START**

Engine fires during start are usually the result of over priming. The first attempt to extinguish the fire is to try to start the engine and draw the excess fuel back into the induction system and blow the fire out.

If fire continues more than a few seconds, the engine should be shut down and the fire extinguished by the best available means.

**ENGINE POWER LOSS DURING TAKEOFF**

The proper action to be taken if loss of power occurs during takeoff will depend on the circumstances of the particular situation.

If sufficient runway remains to complete a normal landing, land straight ahead.

Any turn will increase the risk of stall or stall/spin, fatal at low altitude. Land as straight ahead as practical and maintain a safe airspeed and make only a very shallow turn if necessary to avoid obstructions. Use of flaps depends on the circumstances. Normally, flaps should be fully extended for touchdown.

If sufficient altitude has been gained to attempt a restart, maintain a safe airspeed and check the fuel selector, check the Auxiliary fuel pump to ensure that it is "ON" and that the mixture is "RICH." The carburetor heat should be "ON".

If power is not regained, proceed with the Power Off Landing procedure (refer to the emergency check list).

## SECTION 6

### ZODIAC XL-SLSA WITH 0-200 ENGINE

---

#### ENGINE POWER LOSS IN FLIGHT

Complete engine power loss is usually caused by fuel flow interruption and power will be restored shortly after fuel flow is restored. If power loss occurs at a low altitude, the first step is to prepare for an emergency landing.

If altitude permits, check the fuel and turn the Auxiliary fuel pump **"ON."** Move the mixture control to **"RICH"** and the carburetor heat to **"ON."** Check the gauges for an indication of the cause of the power loss. If no fuel pressure is indicated, check the tank selector position.

When power is restored move the carburetor heat and the Auxiliary fuel pump to **"OFF"**.

If the preceding steps do not restore power, prepare for an emergency landing.

If time permits, turn the ignition switch to **"L"** then to **"R"** then back to **"BOTH."** Move the throttle and mixture control levers to different settings. This may restore power if the problem is too rich or too lean a mixture or if there is a partial fuel system restriction. Water in the fuel could take some time to be used up, and allowing the engine to windmill may restore power. If power loss is due to water, fuel pressure indications will be normal.

(If engine failure was caused by fuel exhaustion power will not be restored after switching fuel tanks until the empty fuel lines are filled. This may require up to six seconds).

If power is not regained, proceed with the Power Off Landing procedure (refer to the emergency check list).

#### POWER OFF LANDING

If loss of power occurs at altitude, trim the aircraft for best gliding angle and look for a suitable field. If measures taken to restore power are not effective, and if time permits, check your charts for airports in the immediate vicinity; it may be possible to land at one if you have sufficient altitude. If possible, notify Air Traffic Control or other facility by radio of your difficulty, position, and intentions.

When committed to a landing, flaps may be used as desired. Turn the fuel selector valve to **"OFF"** and pull the mixture out. Shut **"OFF"** the master and ignition switches. The seat belts and shoulder harness should be tightened. Touchdown should be normally made at the lowest possible airspeed.

## **SECTION 6**

### **ZODIAC XL-SLSA WITH 0-200 ENGINE**

---

#### **FIRE IN FLIGHT**

The presence of fire is noted through smoke, smell and heat in the cabin. It is essential that the source of the fire be promptly identified through instrument readings, character of the smoke, or other indications since the action to be taken differs somewhat in each case.

Check for the source of the fire first.

If an electrical fire is indicated (smoke in the cabin), the master switch should be turned **"OFF."** The cabin vents should be opened and the cabin heat turned **"OFF."** If installed; use fire extinguisher as required. A landing should be made as soon as possible.

If an engine fire is present, switch the fuel selector to **"OFF"** and close the throttle. The mixture should be pulled out. Turn the Auxiliary fuel pump **"OFF."** In all cases, the cabin heat should be pushed **"OFF."** Once final flap configuration is set, select master switch **"OFF."** Proceed with power off landing procedure.

#### **LOSS OF OIL PRESSURE**

Loss of oil pressure may be either partial or complete. A partial loss of oil pressure usually indicates a malfunction in the oil pressure regulating system, and a landing should be made as soon as possible to investigate the cause and prevent engine damage.

A complete loss of oil pressure indication may signify oil exhaustion or may be the result of a faulty gauge. In either case, proceed toward the nearest airport at reduced power setting, and be prepared for a forced landing. If the problem is not a pressure gauge malfunction, the engine may stop suddenly. Maintain altitude until such time as a dead stick landing can be accomplished. Don't change power settings unnecessarily, as this may hasten complete power loss.

Depending on the circumstances, it may be advisable to make an off airport landing while power is still available, particularly if other indications of actual oil pressure loss, such as sudden increases in temperatures, oil or smoke, are apparent, and an airport is not close.

If engine stoppage occurs, proceed with Power Off Landing.

#### **LOSS OF FUEL PRESSURE**

If loss of fuel pressure occurs, switch the Auxiliary fuel pump **"ON"** and check the fuel selector.

Land as soon as practical and have the engine driven fuel pump and fuel system checked.

## SECTION 6

### ZODIAC XL-SLSA WITH 0-200 ENGINE

---

#### HIGH OIL TEMPERATURE

An abnormally high oil temperature indication may be caused by a low oil level, damaged or improper baffle seals, a defective gauge, or other causes. Land as soon as practical at an appropriate airport and have the cause investigated.

A steady, rapid rise in oil temperature is a sign of trouble. Land at the nearest airport and let a mechanic investigate the problem. Watch the oil pressure gauge for an accompanying loss of pressure.

#### ALTERNATOR FAILURE

Loss of alternator output is detected through negative reading on the ammeter. Before executing the following procedure, ensure that the reading is negative and not merely low, by actuating an electrically powered device, such as the flaps. If no increase in the ammeter reading is noted, alternator failure can be assumed.

The electrical load should be reduced as much as possible. Check the alternator circuit breakers for a popped circuit.

The next step is to attempt to reset the overvoltage relay. This is accomplished by moving the "ALT" switch to "OFF" for one second and then to "ON." If the trouble was caused by a momentary overvoltage condition (16.5 volts and up) this procedure should return the ammeter to a normal reading.

If the ammeter continues to indicate "0" output, or if the alternator will not remain reset, turn the "ALT" switch "OFF," maintain minimum electrical load and land as soon as practical. All electrical load is being supplied by the battery only.

#### SPINS

Intentional spins are prohibited. To recover from an unintentional spin: Rudder and aileron against the spin and elevator neutral or slightly forward. Rotation stops quickly. Pull the nose gently up; careful not to exceed the speed and g load limits. If flaps were extended: retract them during recovery.

#### STALLS

When approaching, with **wing level stall** and throttle idle, keep the wings level with smooth rudder until the airplane mashes down (no abrupt brake down). The recovery is quick when pushing the nose down, with less than 15deg. roll and/or 5 deg. your **turning stalls** and **accelerated stalls**, power off have similar characteristics.

For both spins and stalls, when executed correctly, the full recovery will require an altitude loss of less than 150 feet.



## SECTION 6

### ZODIAC XL-SLSA WITH 0-200 ENGINE

---

#### CARBURETOR ICING ENGINE ROUGHNESS

**Note: See Engine Operators Manual**

Engine roughness is usually due to carburetor icing which is indicated by a drop in RPM, and may be accompanied by a loss of airspeed or altitude. If too much ice is allowed to accumulate, restoration of full power may not be possible; therefore, prompt action is required.

Pull carburetor heat on (See Note). RPM will decrease slightly and roughness will increase. Wait for a decrease in engine roughness and increase in RPM, indicating ice removal. If no change in approximately one minute, push the carburetor heat to "**OFF.**"

If the engine is still rough, adjust the mixture for maximum smoothness. The engine will run rough if too rich or too lean. The electric fuel pump should be switched to "**ON**" and the fuel selector checked to see if fuel contamination is the problem. Check the gauges for abnormal readings. If any gauge readings are abnormal, proceed accordingly. Move the magneto switch to "**L**" then to "**R**," then back to "**BOTH.**" If operation is satisfactory on either magneto, proceed on that magneto at reduced power, with mixture pushed full "**RICH,**" to a landing at the first available airport.

If roughness persists, prepare for a precautionary landing at pilot's discretion.

#### **NOTE**

Partial carburetor heat may be worse than no heat at all, since it may melt part of the ice, which will refreeze in the intake system. When using carburetor heat, therefore, always pull full heat, and when ice is removed, push the control to the full cold position.

#### **CANOPY OPENING IN FLIGHT**

- Concentrate on flying the airplane.
- **REDUCE SPEED TO 60 KNOTS**
- **IGNORE THE CANOPY AND WIND NOISE**
- Fly a normal approach and landing including completing the landing checklist
- The canopy will remain raised in an open position about 1 foot
- If the canopy opens after lift-off, do not rush to land.
- Climb to normal traffic pattern altitude, fly a normal traffic pattern, and make a normal landing.
- Do not release the seat belt and shoulder harness in an attempt to reach the canopy. Leave the canopy alone. Land as soon as practicable, and close the canopy once safely on the ground.
- Do not panic. Try to ignore the unfamiliar wind. Also, do not rush. Attempting to get the airplane on the ground as quickly as possible may result in steep turns at low altitude.
- Complete all items on the landing checklist.
- Remember that accidents are almost never caused by an open canopy. Rather, an open canopy accident is caused by the pilot's distraction or failure to maintain control of the airplane.

**SECTION 7**  
**NORMAL PROCEDURES**

SAMPLE

**SECTION 7**

**NORMAL PROCEDURES**

**GENERAL**

This section describes the recommended procedures for the conduct of normal operations for the ZODIAC XL. All of the required procedures and those necessary for the safe operation of the airplane as determined by the operating and design features of the airplane are presented.

Normal procedures associated with those optional systems and equipment which require Pilot Operating Handbook supplements are provided in the Options Section.

These procedures are provided to present a source of reference and review and to supply information on procedures which are not identical for all aircraft. Pilots should familiarize themselves with the procedures given in this section in order to become proficient in the normal operations of the airplane.

**Note: See engine Operators Manual.**

**AIRSPEEDS FOR SAFE OPERATIONS**

The following airspeeds are those which are significant to the safe operation of the ZODIAC XL. These figures are for standard airplanes flown at gross weight under standard conditions at sea level.

Performance for a specific airplane may vary from published figures depending upon the condition of the engine, airplane and equipment, atmospheric conditions and piloting technique.

- |  |                              |
|--|------------------------------|
| (a) Best Rate of Climb Speed ( $V_y$ ) (60 KCAS)           | _____ <b>KIAS</b> Flaps Up   |
| (b) Best Angle of Climb Speed ( $V_x$ ) (58 KCAS)          | _____ <b>KIAS</b> Flaps Up   |
| (c) Turbulent Air Operating Speed: Do not exceed ( $V_c$ ) | _____ <b>KIAS</b> Flaps Up   |
| (d) Landing Final Approach Speed (Flaps down) (55 KCAS)    | _____ <b>KIAS</b> Flaps Down |
| (e) Max flaps down VFE (80 KCAS)                           | _____ <b>KIAS</b>            |
| (f) Never Exceed Speed (140 KCAS)                          | _____ <b>KIAS</b>            |

(also see Page 3.1)



## SECTION 7

### ZODIAC XL-SLSA WITH 0-200 ENGINE

---

- 3 - Check left side of canopy for general condition.
  - Drain fuel sample from the left fuel tank (sump located under each wing) and gascolator (rear of firewall).
  - Inspect left main landing gear and tire for general condition (wear, cuts, abrasions, leaking brakes, tire inflation).
  - Check Pitot static.
- 4 - Visually confirm fuel level in left tank; secure gas cap.
  - Remove left wing tie down.
  - Check left wing surfaces and wing tip for damage.
  - Check condition and security of lights (if installed).
- 5 - Check left aileron for safety.
  - Check left flap for safety
  - Check left aileron for freedom of movement and security.
  - Lower flaps and check safety, left and right wing
  - Bring flaps up to check travel, left and right wing
- 6 - Check rear fuselage for damage - access/inspection panels secured.
  - Check antennas.
- 7 - Check elevator and rudder condition and freedom of movement (do not force!).
  - Check cables and hinges.
  - Check cotter pins at cable ends
  - Check trim tab for security.
  - Remove tail tie down.
  - Check condition and security of tail light (if installed).
- 8 - Check right aileron for safety.
  - Check right flap for safety
  - Check right aileron for freedom of movement and security.
- 9 - Check right wing surface and tip for damage.
  - Remove right wing tie down.
  - Check stall warning for functionality (if installed option).
  - Check condition and security of lights (if installed option).
  - Visually confirm fuel level in right tank; secure gas cap.
- 10 - Inspect right landing gear and tire for general condition (wear, cuts, abrasions, leaking brakes, tire inflation).
  - Check stall warning (Master ON – if installed option)
  - Drain fuel sample from the right fuel tank, and the gascolator again.
  - Check right side of canopy for general condition.
- 11 - Check engine cowling for damage, evidence of leaks, and security of fasteners.
  - Open engine oil door and check engine oil dipstick. Make sure that oil cap is closed tight.
  - Through oil door, check nose gear bungee and firewall for bent channels from hard landings
  - Check security of fastener of oil door.

**SECTION 7**  
**ZODIAC XL-SLSA WITH 0-200 ENGINE**

---

- 12 - Check engine muffler and exhaust for cracks, nicks, and security.
- 13 - Remove tow bar from nose gear if applicable (option).
  - Check nose gear and tire for general condition (wear, cuts, abrasions, tire inflation).
- 14 - Check engine air intake for foreign objects (birds nests).
  - Check propeller nose cone for damage
  - Check propeller for damage.

Physically check fuel level in tank(s) before each take off

**Inside aircraft pre-flight inspection:**

- A. Control stick:** The control stick should have a free and smooth operation throughout its full range of travel. There should be no binding or contact with the cabin frame, seat, or instrument panel. There should be no free-play (slack) in the controls, nor should the controls be tight.
- B. Rudder pedals:** Move the rudder pedals through the full range of rudder travel. The pedal movement should be smooth with no binding. Ensure that shoes will not catch on exposed metal lines, fixtures, or electrical wire harness. Do not move the controls abruptly!
- C. Brakes:** Toe brake pressure should be firm with no tendency to bleed down or lock up. Inspect brake pedal area. There must be no signs of brake fluid leaking.
- D. Instrument panel:** All the instruments should be properly secured in the panel. Check instrument panel and cabin placards.
- E. Engine controls:** All controls should be visually inspected, positive in operation, and securely mounted. The friction locks on controls should be checked for operation. Each control such as engine throttle cable, etc. should have full movement with at least a 1/8 inch of “cushion” at the full travel position.
- F. Safety belt and shoulder harness:** These items should be checked for condition and proper installation and locking.
- G. Avionics and electrical checks:** Test the avionics systems. Perform an operational check to ensure the radio(s) transmit and receive on desired frequencies. Inspect circuit breakers/fuses, microphones, and antennas for security and operation. Test the ELT for proper operation and battery life. Electrical systems can be checked for operation of lights, instruments, and basic nav/com performance. Other electrical systems, such as generator/alternator output can be checked during the engine run-up, and taxi.

**SECTION 7**  
**ZODIAC XL-SLSA WITH 0-200 ENGINE**

---

**H. Canopy locks check:** Ensure the canopy on the aircraft functions as necessary. From inside the aircraft, check the canopy locks left and right so that the canopy will not open in flight.

**I. Weight and Balance:** The weight and balance for the aircraft should be carefully done. The gross weight and CG range should be determined prior to every flight.

**J. Airworthiness/Registration/Operating Limitations/Placards/Weight & Balance, Pilot Operating Handbook:** Must be on board.

**K. IFR.** Ensure that before flying in IFR conditions, that your aircraft is equipped as per Supplement #2.

SAMPLE

## SECTION 7

### ZODIAC XL-SLSA WITH 0-200 ENGINE

---

#### BEFORE STARTING THE ENGINE

Operate the controls and check for proper operation. Make sure the windshield is clean for best visibility. Check brakes, and fasten and check seat belt + harness.

Warning: Canopy must be closed securely when engine is on.

**Perform Preflight check list on previous pages.**

***CAUTION . . . This section pertains to operation under average climatic conditions. The pilot should thoroughly familiarize himself with Section V, Abnormal Operating Conditions in the Engine Operators Manual. Whenever such abnormal conditions are encountered or anticipated the procedures and techniques for normal operation should be tailored accordingly. For example, if the aircraft is to be temporarily operated in extreme cold or hot weather, consideration should be given to an early oil change and / or a routine inspection servicing.***

**GENERAL - See check list in Engine Operators Manual Section II**

The life of your engine is determined by the care it receives. Follow the instructions contained in this manual carefully.

The engine receives a run-in operation before leaving the factory. Therefore, no break-in schedule need be followed. Straight mineral oil (MIL-C-6529 Type II) should be used for the first oil change period (25 hours)

The minimum grade aviation fuel for this engine 80/87. In case the required is not available, use the grade required is not available, use a higher rating. Never use a lower rated fuel.

**WARNING. . . The use of a lower octane rated fuel can cause pre-ignition and/or detonation which can damage an engine the first time high power is applied. This would most likely occur on takeoff. If the aircraft is inadvertently serviced with the wrong grade of fuel, then the fuel must be completely drained and the tank properly serviced.**

#### PRESTARTING.

Before each flight the engine and propeller should be examined for damage, oil leaks, security and proper servicing.

1. Position the ignition switch to the "OFF" position.
2. Operate all controls and check for binding and full range of travel.
3. Assure that fuel tanks contain proper type and quantity of fuel.
4. Drain a quantity of fuel from all sumps and strainers into a clean container. If water or foreign matter is noted, continue draining until only clean fuel appears.



## SECTION 7

### ZODIAC XL-SLSA WITH 0-200 ENGINE

---

5. Check oil level in sump.
6. Check cowling for security.

Note: The aircraft is equipped with an “auxiliary fuel pump”, operated by an electric switch on the instrument panel. It is recommended that the pump be turned “ON” before turning engine on and left on during take-off and climb. It is recommended that the pump be turned “ON” when descending, on final and landing. When pump is “ON” one should see a slight increase in fuel pressure.

#### STARTING

1. Fuel Selector – On.
2. Battery Switch – On.
3. Ignition Switch – On.
4. Mixture – Full Rich.
5. Throttle – Full Open.
6. Prime – Turn switch ON for 2-3 seconds.

NOTE . . . The amount of prime required depends on engine temperature. Familiarity and practice will enable the operator to estimate accurately the amount of prime to use. If the engine is hot, do not prime before starting. Aircraft may be equipped with a manual primer. Prime 4-5 strokes. After priming, turn primer handle completely “OFF” to avoid possibility of engine drawing fuel through the primer. Throttle – Open approximately 1 inch.

7. Auxiliary fuel pump – On.
8. Starter – Engage until engine starts, then release.

**Caution . . . Do not engage the starter when the engine is running as this will damage the starter. If difficulty in starting is experienced, do not crank for longer than thirty seconds at a time as the starter motor may overheat. If the engine does not start after thirty seconds of cranking, allow a 3 to 5 minute cooling period before continued attempts. If flooding is suspected proceed as follows:**

1. **Throttle – Open**
2. **Mixture – Idle Cutoff.**
3. **Starter – Engage until engine starts, then release.**
4. **Throttle Retard to 1200 RPM.**

## SECTION 7

### ZODIAC XL-SLSA WITH 0-200 ENGINE

---

#### 5. *Mixture – Full Rich.*

9. Oil Pressure – Check.. If no oil pressure is noted within 30 seconds (60 seconds in cold weather), shut down the engine and investigate.

#### GROUND RUNNING; WARM-UP.

Teledyne Continental aircraft engines are air-cooled and therefore dependent on the forward speed of the aircraft for cooling. To prevent overheating, it is important that the following rules be observed.

1. Head the aircraft into the wind.
2. Avoid prolonged idling at low RPM. Fouled spark plugs can result from this practice.
3. Leave mixture in “Full Rich”. (See “**Engine Operators Manual** Ground Operation at High Altitude Airports”, Section V, for exceptions.)
4. Warm-up 900-1200 RPM.

#### PRE-TAKEOFF CHECK

1. Maintain engine speed at approximately 900 to 1000 RPM for at least one minute in warm weather, and as required during cold weather to prevent cavitation in the oil pump and to assure adequate lubrication.
2. Advanced throttle slowly until tachometer indicates an engine speed of approximately 1200 RPM. Allow additional warm-up time at this speed depending on ambient temperature. This time may be used for taxiing to takeoff position. The minimum allowable oil temperature for run-up is 75°F.

**CAUTION . . . Do not operate the engine at run-up speed unless oil temperature is 75 °F. Minimum.**

3. Perform all cowling operations with cowling flaps, if installed; full open, with mixture control in “FULL RICH” position.
4. Restrict ground operations to the time necessary for warm-up and testing.

NOTE . . Carburetor ice can form on the ground with the engine idling. Therefore, just before take-off and during the magneto check, position the carburetor heat to “ON”. Leave it in that position until the throttle is advanced for the take-off run, then position the carburetor heat to “cold air”. This gives maximum power for take-off. Monitor engine for any indication of ice (roughness or loss of RPM) during climb and add full carburetor heat at the first sign of icing. The correct way to use carburetor heat is to first apply full heat to remove any ice that has formed by applying full heat.

## SECTION 7

### ZODIAC XL-SLSA WITH 0-200 ENGINE

---

5. Increase engine speed to 1700 RPM only long enough to perform the following checks:
  - a. Check Magnetos: Move the ignition switch to “R” position and note engine RPM, then move switch back to “BOTH” position to clear the other set of spark plugs. Then move the switch to “L” position and note RPM. The difference between the two magnetos operated individually should not differ more than 75 RPM. Observe engine for excessive roughness during this check. Maximum allowable drop when operating on one magneto is 150 RPM.

If no drop in RPM is observed when operating on either magneto alone, the switch circuit should be inspected.

**WARNING . . . Absence of RPM drop when checking magnetos may indicate a malfunction in the ignition circuit. Should the propeller be moved by hand (as during preflight) the engine may start and cause injury to personnel. This type of malfunction should be corrected prior to continued operation of the engine.**

***CAUTION . . . Do not underestimate the importance of a pre-takeoff magneto check. When operating on single ignition, some RPM drop should be noted. Normal indications are 25-75 RPM drop and slight engine roughness as each magneto is switched off. Absence of a magneto drop may be indicative of an open switch circuit or improperly timed magneto. An excessive RPM drop usually indicates a faulty magneto or fouled spark plugs.***

Minor spark plug fouling can usually be cleared as follows:

1. Magnetos – Both On.
2. Throttle – 2200 RPM.
3. Mixture – Move toward idle cutoff until RPM peaks and hold for ten seconds. Return mixture to full rich.
4. Magnetos – Recheck.

If the engine is not operating within specified limits, it should be inspected and repaired prior to continued operational service.

Avoid prolonged single magneto operation to preclude fouling of the spark plugs.

***CAUTION . . . Do not operate the engine at a speed in excess of 1700 RPM longer than necessary to test operation and observe engine instruments. Proper engine cooling depends upon forward speed of the aircraft. Discontinue testing if temperature or pressure limits are approached.***

## **SECTION 7**

### **ZODIAC XL-SLSA WITH 0-200 ENGINE**

---

6. Instrument Indications.
  - a. Oil Pressure: The oil pressure relief valve will maintain pressure within the specified limits if the oil temperature is within the specified limits and if the engine is not excessively worn or dirty. Fluctuating or low pressure may be due to dirt in the oil pressure relief valve or congealed oil in the system.
  - b. Oil Temperatures: The oil cooler will maintain oil temperature within the specified range unless the cooler oil passages or air channels are obstructed. Oil temperature above the prescribed limit may cause a drop in oil pressure, leading to rapid wear of moving parts in the engine.
  - c. Cylinder Head Temperature: Any temperature in excess of the specified limit may cause cylinder or piston damage. Cooling of cylinders depends on cylinder baffles being properly positioned on the cylinder heads and barrels, and other joints in the pressure compartment being tight so as to force air between the cylinder fins. Proper cooling also depends on operation practices. Fuel and air mixture ratio will affect cylinder temperature. Excessively lean mixture causes overheating even when the cooling system is in good condition. High power and low air speed, may cause overheating by reducing the cooling air flow. The engine depends on ram air flow developed by the forward motion of the aircraft for adequate cooling.
  - d. Battery Charging: The ammeter should indicate a positive charging rate until the power used for starting has been replaced by the battery charging circuit, unless the electrical load on the alternator is heavy enough to require its full output. The ammeter reading should return to the positive side as soon as the load is reduced. A low charging rate is normal after the initial recharging of the battery. A zero reading or negative reading with no battery load indicates a malfunction in the alternator or regulator system.

### **TAXIING**

With the tricycle configuration, taxiing is easy with the use of the steerable nose wheel. Avoid steering the aircraft with the brakes. When winds exceed 15 to 20 mph, taxi very slowly and carefully. Position control surfaces to prevent inadvertent lift-off.

Check: flight instruments and radio aids: functioning correctly.

- Check flaps up.
- Set trim to neutral / take off position.
- Check fuel selector valve.
  
- Check oil pressure and oil temperature.
- Check fuel quantity.
- Check Volts and Amp meter.
  
- Check all lights (if installed), select as required.
- Check and set radios and Navigation aids (if installed).
- Check mixture pushed "**RICH**", Auxiliary fuel pump "**ON**".

**SECTION 7**  
**ZODIAC XL-SLSA WITH 0-200 ENGINE**

---

- Set throttle for 1700 RPM. Check magnetos from "**BOTH**" to "**R**", then from "**BOTH**" to "**L**", and back to "**BOTH**" (on either one magneto, the RPM drop is approximately 100).
- Pull carburetor heat to check operation. (RPM will decrease by approximately 100 at 1700 RPM). Push carburetor heat in after check.
  
- Set Altimeter.
  
- Fasten seat belts, tighten (but not uncomfortably).
- Check that canopy is locked securely (both sides).
- Check freedom and deflection of controls.

**NORMAL TAKEOFF.**

- a. Release brakes
- b. Position mixture to "FULL RICH".
- c. Slowly advance throttle to Full Throttle.
- d. Rotate approximately at  $V_y$

***CAUTION . . . Avoid rapid throttle operation.***

**WARNING**

Do not take off if:

- The engine is running unsteadily
- The engine instruments values are beyond operational limits
- The crosswind velocity exceeds permitted limits or your capacity to control the airplane.
- The auxiliary fuel pump is not working

**CLIMB.**

Climb must be done at "FULL RICH" mixture setting,

**BEST ANGLE OF CLIMB ( $V_x$ ):**

Approx. \_\_\_\_\_ **KIAS** (58 KCAS). This will provide the greatest altitude gain in the shortest distance. (steepest angle of climb for short fields with obstruction)

## SECTION 7

### ZODIAC XL-SLSA WITH 0-200 ENGINE

---

#### **BEST RATE OF CLIMB (V<sub>y</sub>):**

\_\_\_\_\_ **KIAS** (60 KCAS). This will provide the greatest altitude gain in the shortest time.

1. Throttle - Max. power (Max. cont. power 2750 rpm)
2. Trim - trim the airplane
3. Instruments – check oil temperature and pressure are within limits

#### **CAUTION**

If the oil temperature and or oil pressure exceed their limits, reduce the climb angle to increase airspeed in order to stay within the limits.

#### **CRUISE.**

1. After a desired altitude has been reached, adjust the throttle so as not to exceed the RPM for the cruise power selected.
2. Any irregularities in RPM, oil temperature and oil pressure may be indicative of engine trouble. Land as soon as practical and investigate.
3. At altitudes of more than 5,000 feet above sea level adjust mixture control for best rich power by moving toward “lean” position until maximum RPM is obtained with fixed throttle.

***CAUTION . . . Do not lean the fuel-air mixture, unless such adjustment results in a higher RPM. Excessively lean mixtures cause over-heating and may result in damage to the engine.***

Elevator and Aileron Trim (optional) - - ADJUST to throttle setting and speed.

Auxiliary fuel pump "**OFF**".

#### **CRUISE RPM**

Set cruise. Maximum 2550 RPM

Lower RPM means slower cruise speed, quieter flying, better fuel economy, lower engine temperatures, and increased endurance.

See Page 5.3 for cruise at altitude.

**SECTION 7**  
**ZODIAC XL-SLSA WITH 0-200 ENGINE**

---

**APPROACH – BEFORE LANDING**

**PRE LANDING CHECK**

Auxiliary Fuel Pump . . . . . ON  
Mixture . . . . . RICH  
Carburetor heat . . . . . ON  
Flaps . . . . . As Required  
Speeds . . . . . As Required  
Harness . . . . . Tight  
Lights (option) . . . . . As Required

**DESCENDING AND LANDING.**

1. The mixture control must be “FULL RICH” position during descent.
2. If a long glide is made, apply power at short intervals to clear the cylinders and retain engine temperatures in the event that instant power is required.
3. Carburetor heat is available only at engine outputs well above idle. Apply carburetor heat before closing the throttle and place carburetor heat “OFF” before opening the throttle so full power will be available if necessary.

**CROSS WIND LANDING:**

Approach with one wing low, or use crabbing technique, or a combination of both. Straighten the aircraft out just before touchdown.

NOTE: Sideslips using large rudder inputs MAY be accompanied by a significant nose-down pitching tendency. A strong aft, longitudinal control force may be required to hold the nose up.

NOTE: Very large rudder pedal input results in a significant roll. These maneuvers serve no useful purpose and should be avoided.

NOTE: When extending the flaps, the sink rate increases substantially: this may lead to hard landings if not taken into account.

**APPROACH AND LANDING:**

1. Approach Airspeed – \_\_\_\_\_ **KIAS** (60 KCAS) (**flaps UP**).
2. Trim -- ADJUST.
3. Landing speed of \_\_\_\_\_ **KIAS** (60 KCAS) to \_\_\_\_\_ **KIAS** (65 KCAS)
4. Touchdown -- MAIN WHEELS FIRST.
5. Landing Roll -- LOWER NOSE WHEEL GENTLY – by pulling stick back.
6. Braking-- MINIMUM REQUIRED.

**APPROACH AND LANDING:**

1. Approach Airspeed – \_\_\_\_\_ **KIAS** (55 KCAS) (**flaps DOWN**).
2. Trim -- ADJUST.
3. Landing speed of \_\_\_\_\_ **KIAS** (55 KCAS) to \_\_\_\_\_ **KIAS** (60 KCAS)
4. Touchdown -- MAIN WHEELS FIRST.
5. Landing Roll -- LOWER NOSE WHEEL GENTLY – by pulling stick back.
6. Braking-- MINIMUM REQUIRED.

**Note 1:** Increase power and speed if the rate of sink is too high (see note of landing distance).

**Note 2:** In gusty weather, increase the approach speed to \_\_\_\_\_ **KIAS** (65 KCAS) with flaps down.

**AFTER LANDING CHECK**

Flaps .....UP  
Lights .....As Required  
Radios and Nav aids .....As Required



**SECTION 7**  
**ZODIAC XL-SLSA WITH 0-200 ENGINE**

---

**SHUT DOWN (Engine)**

|  |          |
|--|----------|
| Magnetos . . . . .                     | Check    |
| Radios and Nav aids . . . . .          | OFF      |
| External lights . . . . .              | OFF      |
| Auxiliary Fuel pump . . . . .          | OFF      |
| Mixture . . . . .                      | PULL/OUT |
| MAGs. (when propeller stops) . . . . . | OFF      |
| MASTER . . . . .                       | OFF      |
| All switches . . . . .                 | OFF      |

Remove ignition key when aircraft is unattended.

NOTE: The hour-meter counts "engine time" from the moment the master switch is turned on. Do not forget to turn the master switch off.

NOTE: 1. Normally the engine will have cooled sufficiently during the glide and taxiing period to permit placing the ignition switch in the off position without additional idling. If taxi time has been excessive, operate the engine at 1700 RPM for two or three minutes before stopping.

NOTE:2. If the engine is equipped with a Stromberg NA-53A1 carburetor, stop from idling speed by turning the ignition switch to "OFF". As the engine stops open the throttle rapidly, and leave it open to prevent after-firing. If the carburetor is a Marvel-Schebler MA-3PA model, stop by moving the mixture control to the full "lean" position, where it acts as an idle cut-off. Do not open throttle, because it actuates the accelerator pump and rapid opening will flood the engine.

**TIE DOWN**

When the aircraft is not in use, it should be anchored to the tie down rings located under each wing and at the rear fuselage. Tie the control forward. Make sure the canopy is locked on both sides. The optional canopy cover will minimize dust, or damage to the canopy (and keep curious onlookers out).

NOTE: When aircraft is equipped with a "Parking Brake" (optional), it is important to always tie down the plane when it is not attended.

## **SECTION 7**

### **ZODIAC XL-SLSA WITH 0-200 ENGINE**

---

#### **SHORT FIELD TAKEOFF**

Same procedure as normal take off

#### **SHORT FIELD LANDING**

Same procedure as normal landing

#### **BALKED LANDINGS:**

- 1, Push throttle full open
- 2, Retract flaps.
- 3, Carb. heat close

With less than 4 seconds, the airplane climbs again as per Rate of Climb chart.

#### **CROSS WIND LANDING:**

Approach with one wing low, or use crabbing technique, or a combination of both. Level and straighten the aircraft just before touchdown.

NOTE: When extending the flaps, the sink rate increases substantially: This may lead to hard landings if not taken into account.

#### **CAUTION**

Rapid engine cooling should be avoided during operation. This happens above all during aircraft descent, low engine rpm or at engine shutdown immediately after landing. Under normal conditions the engine temperatures stabilize during descent to values suitable to stop engine by switching the ignition off. If necessary, cool the engine at 1700 rpm to stabilize the temperatures prior to engine shut down.

#### **EXTREME HOT WEATHER OPERATION**

The standard airflow provides proper engine cooling up to a Sea Level temperature of 100°F (38°C). If operation above this temperature is required, care must be taken not to overheat the engine. This is achieved by:

- minimizing ground warm up
- checking the oil temperature after the full throttle initial climb out: if the oil temperature is increasing beyond 200°, power must be reduced and/or a faster climb speed selected. It is necessary to initiate the corrective action before the oil reaches the Red line (225°F) as there is a time lag between engine operation and associated oil temperatures.

CAUTION: When climbing at reduced power or faster speed, the rate of climb is reduced. See Engine Operators Manual for more information on hot weather operation.

**SECTION 8**

**AIRCRAFT GROUND HANDLING AND SERVICING**

**SAMPLE**

**SECTION 8**

**AIRCRAFT GROUND HANDLING AND SERVICING**

**GENERAL**

This section provides general guidelines relating to the handling, servicing and maintenance of the ZODIAC.

Section F2295 of the ASTM LSA lists the Owner/Operator Responsibilities for Continued Operational Safety Monitoring of a Light Sport Airplane. Complete and submit Form #1 in the Maintenance Manual for maintenance, service and safety difficulties.

Review the aircraft records for outstanding “SAFETY ALERTS”, “SERVICE BULETINS” and “NOTIFICATIONS”. You must contact the manufacture for the latest list of above documents. **Manufacturer can be contacted by telephone at 478-374-2759 or by fax at 478-374-2793 or by mail at 415 Airport Road, Eastman GA, 31023 USA.**

For engine and propeller Service Bulletins, Airworthiness Directives, and Service Letters, contact the original manufacturers.

**“SAFETY ALERTS” are for notifications that require immediate action.**

**“SERVICE BULETINS” are for notifications that do not require immediate action but do recommend future actions.**

**“NOTIFICATIONS” are for notifications that do not necessarily recommend future action but are primarily for promulgation of continued airworthiness information.**

A Maintenance Manual, Parts Manual, and revisions to both, are available from AMD. Any correspondence regarding the airplane should include the airplane model and serial number to ensure proper response.

**Before performing any type of maintenance on the aircraft, read the manufacturer’s warranty forms to make sure you remain in compliance (to not inadvertently void the warranties).**

**When maintaining the aircraft yourself, make sure that you are authorized to do the work. See the aircraft Maintenance Manual and LSA rules for details.**

**SECTION 8**  
**ZODIAC XL-SLSA WITH 0-200 ENGINE**

---

**SERVICING FUEL** - See Maintenance Manual.

(a) Servicing Fuel System

At every 50 hour inspection, the fuel screen in the gascolator and at the carburetor inlet must be cleaned. See Maintenance Manual.

(b) Fuel Requirements

See Engine Manual

(c) Draining Fuel Strainer, Sumps and Lines

The fuel system sumps and strainer should be drained daily prior to the first flight and after refueling to avoid the accumulation of contaminants such as water or sediment. Each fuel tank is equipped with an individual quick drain located at the lower wing surface. The gascolator is equipped with an individual quick drain located under the fuselage. Each of the fuel tank sumps should be drained first. Then the gascolator should be drained with the fuel selector valve on each individual tank. Each time fuel is drained, sufficient fuel should be allowed to flow to ensure removal of contaminants. This fuel should be collected in a suitable container, examined for contaminants, and then discarded.

**CAUTION**

After draining any amount of fuel, care should be taken to ensure that no fire hazard exists before starting the engine.

After draining, each quick drain should be checked to make sure it has closed completely and is not leaking.

**SECTION 8**  
**ZODIAC XL-SLSA WITH 0-200 ENGINE**

---

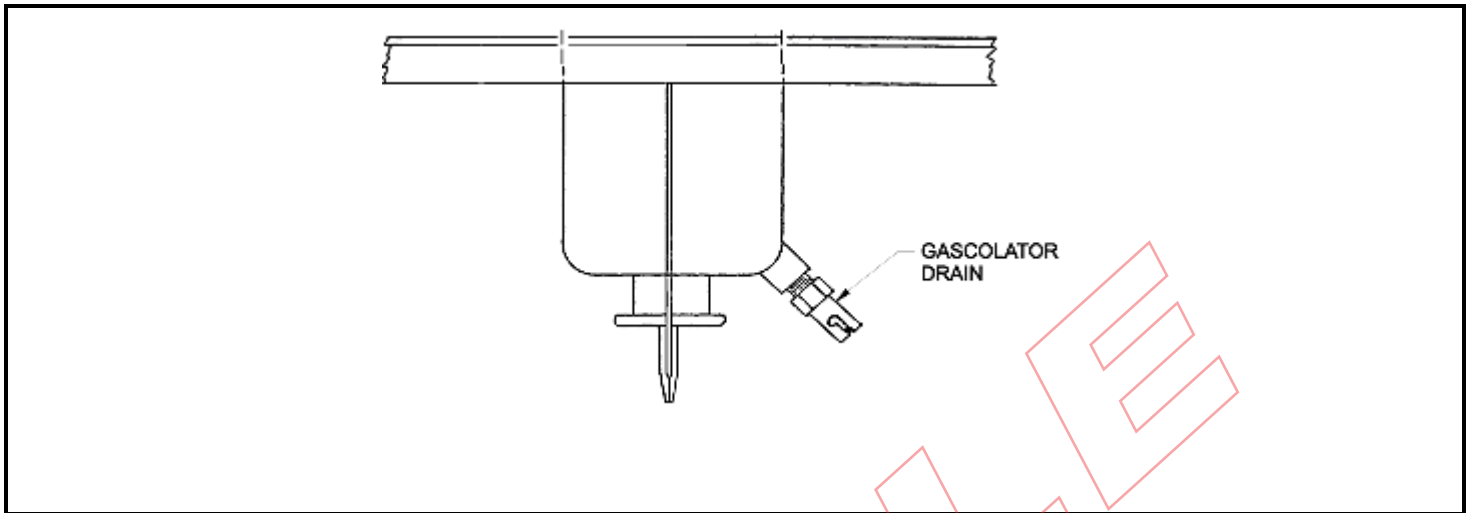

**FUEL DRAINS**

(d) Draining Fuel System

The bulk of the fuel may be drained from the system by opening the valves at the lower wing Surface near the fuselage. The remaining fuel is drained from the gascolator quick drain with the fuel selector set to each individual tank. Push the drain valve stem(s) to open the drain.

**OIL REQUIREMENTS**

See Engine Operators Manual.

Oil Sump Capacity: 4-5 U.S. Quarts

Oil Change Interval: 50 hours

It is recommended that the oil be changed as per instructions in the Engines Manual. Should fuel other than the specified octane rating for the power plant be added to tanks, do not fly the aircraft and immediately contact your mechanic.

The filler cap/dipstick is accessible through an access door in the engine cowling. Refer to the Maintenance Manual for the correct procedure for changing the oil and oil filter etc.

**SECTION 8**  
**ZODIAC XL-SLSA WITH 0-200 ENGINE**

---

**OIL TYPE:**

Normal service: SAE 50 (above 40 deg. F)  
SAE 30 (below 40 deg. F)  
See Engine Operators Manual section VII for Approved products.

**GROUND HANDLING:** the airplane may be moved on the ground by:

**WARNING: Ignition "OFF"**

- (a) Pushing on the wing leading edges at rib location, apply hand pressure on the wing rib rivet lines.

**WARNING: DO NOT push or lift through the elevator or propeller area.**

- (b) Towing by the use of the nose wheel steering bar (option) or by power equipment that will not damage or excessively strain the nose gear steering assembly.

**CAUTION**

When towing with power equipment, do not turn the nose gear beyond its steering radius in either direction, as this will result in damage to the nose gear and steering mechanism.

**CAUTION**

Do not tow the airplane when the controls are locked.

- (c) Taxiing

Before attempting to taxi the airplane, ground personnel should be instructed and approved by a qualified person authorized by the owner. Engine starting and shut-down procedures as well as taxi techniques should be covered. When it is ascertained that the propeller back blast and taxi areas are clear, power should be applied moderately to start the taxi roll, and the following checks should be performed:

- Taxi a few feet forward and apply the brakes to determine their effectiveness.
- While taxiing, make slight turns to ascertain the effectiveness of the steering.
- Observe wing clearance when taxiing near buildings or other stationary objects. If possible, station an observer outside the airplane.
- When taxiing over uneven ground, avoid holes and ruts.
- Do not operate the engine at high RPM when running up or taxiing over ground containing loose stones, gravel, or any loose material that may cause damage to the propeller blades.

**SECTION 8**  
**ZODIAC XL-SLSA WITH 0-200 ENGINE**

---

(d) Parking

When parking the airplane, be sure that it is sufficiently protected from adverse weather conditions and that it presents no danger to other aircraft. When parking the airplane for any length of time or overnight, it is suggested that it be moored securely (tied down). When parking the airplane, face it into the wind if possible and use chocks to properly block the wheels.

(e) Tie Down

The airplane should be tied down for immovability, security and protection. The following procedures should be used for the proper mooring of the airplane:

- Face the airplane into prevailing winds if possible.
- Retract the flaps.
- Block the wheels.
- Secure tie-down ropes to the wing tie-down rings and to the tail ring at approximately 45 degree angle to the ground. When using rope of non-synthetic material, leave sufficient slack to avoid damage to the airplane should the ropes contract.

**CAUTION**

Use bowline knots, square knots or locked slip knots. Do not use plain slip knots.

**NOTE**

Additional preparations for high winds include using tie-down ropes from the landing gear wheel area and securing the rudder.

Install a pitot cover if available. Be sure to remove the pitot cover before flight. Canopy should be locked when the airplane is unattended. The optional canopy cover will protect the canopy from dust, the interior from ultraviolet rays, and will discourage unwanted onlookers.



## SECTION 8

### ZODIAC XL-SLSA WITH 0-200 ENGINE

---

#### CLEANING

(a) Cleaning Engine Compartment

Place a large pan under the engine to catch waste.

With the engine cowling removed, spray or brush the engine with solvent or a mixture of solvent and degreaser. It may be necessary to also brush areas that were sprayed.

#### CAUTION

Do not spray solvent into the alternator, vacuum pump, starter, electrics, or air intakes.

For best results, allow the solvent to remain on the engine from five to ten minutes; Then rinse the engine clean with additional solvent and allow to dry. Make sure you follow the solvent manufacturer's instructions. Also check with the engine manufacturer as to make sure that the solvent is compatible with the engine.

#### CAUTION

Do not operate the engine until solvent has evaporated or otherwise been removed.

Lubricate the controls, bearing surfaces, etc. See Maintenance Manual.

## SECTION 8

### ZODIAC XL-SLSA WITH 0-200 ENGINE

---

#### (b) Cleaning Exterior Surfaces

The airplane should be washed with a mild soap (dishwashing) and water. Harsh abrasives, alkaline soaps or detergents could scratch paint or plastic surfaces or could cause corrosion of metal. Cover areas where cleaning solution could cause damage. To wash the airplane, use the following procedure:

- Flush away loose dirt with water.
- Apply cleaning solution with a soft cloth, a sponge or a soft bristle brush.
- To remove exhaust stains, allow the solution to remain on the surface longer.
- To remove stubborn oil or grease, use a cloth dampened with naphtha.
- Rinse all surfaces thoroughly.
- Any good automotive wax may be used to preserve painted surfaces. Soft cleaning cloths or a chamois should be used to prevent scratches when cleaning or polishing. A heavier coating of wax on leading surfaces will reduce abrasion problems in these areas.

#### (c) Cleaning the Canopy

Clean only with special cleaner to make sure that the canopy is not damaged, to avoid scratches and/or discoloring, using a woolen cleaning cloth.

#### **CAUTION**

Do not use gasoline, alcohol, benzene, carbon tetrachloride, thinner, acetone, or window cleaning sprays, on the canopy.

#### **CAUTION**

To avoid scratches, never remove dust with a dry cloth.

#### (d) Cleaning Headliner, Side Panels and Seats

Clean headliner, side panels, and seats with a stiff bristle brush, and vacuum where necessary. Soiled upholstery, may be cleaned with a good upholstery cleaner suitable for the material.

## **SECTION 8**

### **ZODIAC XL-SLSA WITH 0-200 ENGINE**

---

#### **AIRPLANE INSPECTION PERIODS**

See Maintenance Manual for inspection frequency, details of inspections and who is authorized to perform the inspections.

#### **ANNUAL INSPECTION:**

An annual inspection is required once a year to keep the Airworthiness Certificate in effect. See Table 1 in the Maintenance Manual.

#### **100-HOUR INSPECTION: PER LSA RULES**

One hundred hour inspections are required by law if the aircraft is used for commercial purposes (rental, training, etc.). Aircraft warranty will be void if inspections are not in accordance with Table #1 of the Maintenance Manual. Inspections must be carried out by an authorized person as listed in the Maintenance Manual. The 100 hour inspection is a complete check of the aircraft and its systems, and should be accomplished by an Authorized person as outlined in the Maintenance Manual. The inspection is listed, in detail, in the inspection report of the appropriate Maintenance Manual.

#### **50-HOUR INSPECTION:**

It involves routine and detailed inspections at 50 hour intervals. The purpose of the program is to allow maximum utilization of the aircraft, to reduce maintenance inspection cost and to maintain a maximum standard or continuous airworthiness. See Maintenance Manual for details.

#### **OPTIONAL MONITORING:**

A spectrographic analysis of the oil is available from several sources. This system, if used intelligently, provides a good check of the internal condition of the engine. For this system to be accurate, oil samples must be sent in at regular intervals, and induction air filters must be cleaned or changed regularly. Check with your A&P.

**SECTION 8**  
**ZODIAC XL-SLSA WITH 0-200 ENGINE**

---

**PREVENTATIVE MAINTENANCE**

As per FAA regulations, the FAA authorizes aircraft owners who holder at least a Sport Pilot certificate to perform maintenance as outlined in 14 CFR Part 43. This maintenance may be performed only on an aircraft which the pilot owns or operates and which is not used in commercial service.

Although maintenance as listed in Appendix 2 - section (C) - in the Maintenance Manual is allowed by the pilot, each individual should make a self-analysis as to whether he or she has the ability to perform the work.

If the above work is accomplished, an entry must be made in the appropriate logbook. The entry should contain:

- (a) The date the work was accomplished.
- (b) Description of the work.
- (c) Number of hours on the aircraft.
- (d) The certificate number of pilot performing the work.
- (e) Signature of the individual doing the work.

**Before performing maintenance on the engine, see Engine Operators Manual.**

**SECTION 8**  
**ZODIAC XL-SLSA WITH 0-200 ENGINE**

---

**AIRPLANE ALTERATIONS**

See the Maintenance Manual for details (Appendix 2)

The owner or pilot is required to ascertain that the following Aircraft Papers are in order and in the aircraft.

**AIRPLANE DOCUMENTS**

- (a) To be displayed in the aircraft at all times:
  - (1) Aircraft Certificate of Airworthiness
  - (2) Aircraft Certificate of Registration
  
- (b) To be carried in the aircraft at all times.
  - (1) Pilot Operating Handbook.
  - (2) Weight and Balance and equipment list

Although the aircraft and engine logbooks are not required to be in the aircraft, they should be made available upon request. Logbooks should be complete and up to date. Good records will reduce maintenance costs by giving the mechanic information about what has or has not been accomplished.

## **SECTION 8**

### **ZODIAC XL-SLSA WITH 0-200 ENGINE**

---

#### **ENGINE AIR FILTER**

The air filter must be inspected at least once every fifty hours. Under extremely adverse operating conditions, it may be necessary to inspect the filter more frequently. The filter is disposable and inexpensive and a spare should be kept on hand for rapid replacement.

##### **(a) Removal of Engine Air Filter**

The filter is located in the rear top area of the engine compartment, and may be removed by the following procedure:

- Remove the upper and lower engine cowlings.
- Remove the air filter.

##### **(b) Installation of Engine Air Filter**

When replacing the filter, install the new filter and re-tighten hose clamps / safety.

#### **BRAKE SERVICE**

The brake system is filled with hydraulic fluid MIL-H-5606 (or aero fluid 41). The fluid level should be checked periodically or at every 50 hour inspection and replenished when necessary.

No adjustment of the brake clearances is necessary. If after extended service, brake blocks become excessively worn, they should be replaced with new segments.

#### **BATTERY SERVICE**

The battery should be checked for proper fluid level if it is not a dry cell type of battery. DO NOT fill the battery above the baffle plates. DO NOT fill the battery with acid - use only distilled water. A hydrometer check will determine the percent of charge in the battery.

If the battery is not up to charge, recharge starting with a 6 amp rate and finishing with a 2 amp rate. Quick charges are not recommended.

## **SECTION 8**

### **ZODIAC XL-SLSA WITH 0-200 ENGINE**

---

#### **TIRE INFLATION**

For maximum service from the tires, keep them inflated to the proper pressure = 30 PSI. All wheels and tires are balanced before original installation, and the relationship of tire, tube and wheel should be maintained upon reinstallation. Unbalanced wheels can cause extreme vibration in the landing gear; therefore, when installing new components, it may be necessary to rebalance the wheels with the tires mounted. When checking tire pressure, examine the tires for wear, cuts, bruises, and slippage.

#### **LANDING GEAR SERVICE**

The main landing gear as well as the nose gear carries 5.00 x 5 wheels. All three tires are + four-ply rating, type III tires with tubes.

The nose gear shock chord (bungee) should be checked for chaffing, and elasticity.

In jacking the aircraft for landing gear or other service, use a padded sawhorse under the rear fuselage and lift (hang) the front of the plane by the engine (using ring on crankcase).

#### **PROPELLER SERVICE**

The spinner and backing plate should be frequently cleaned and inspected for cracks. Before each flight the propeller should be inspected for nicks, scratches, paint chips etc. Read the propeller manufacturers maintenance procedures.

#### **NEW ENGINE BREAK-IN AND OPERATION**

The engine underwent a run-in at the factory and is ready for a full range of use. See Engine Manual for details.

#### **CONTROL SURFACE DEFLECTIONS**

See ZODIAC Parts Manual.

**SECTION 9**

**PLACARDS AND MARKINGS**



**SAMPLE**



**SECTION 9**  
**ZODIAC XL-SLSA WITH 0-200 ENGINE**

---

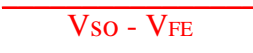
**AIRSPEED INDICATOR MARKINGS**

| <b>MARKING</b> | <b>INDICATED AIRSPEED Kts</b>   | <b>SIGNIFICANCE</b>  |
|----------------|---|--|
| White Arc      |  | <i>Full Flap Operating Range.</i> Lower limit is maximum weight stalling speed in landing configuration. Upper limit is maximum speed permissible with flaps extended. |
| Green Arc      |  | <i>Normal Operating Range.</i> Lower limit is maximum weight stalling speed with flaps up. Upper limit is maximum structural cruising speed.                           |
| Yellow Arc     |  | <i>Calm Weather Range.</i> Operations must be conducted with caution and only in smooth air.   |

**INSTRUMENT MARKINGS**

| <b>INSTRUMENT</b>                |              | Red Line             | Green Arc               | Yellow Line          | Red Line             |
|----------------------------------|--------------|----------------------|-------------------------|----------------------|----------------------|
|                                  |              | <b>MINIMUM LIMIT</b> | <b>NORMAL OPERATING</b> | <b>CAUTION LIMIT</b> | <b>MAXIMUM LIMIT</b> |
| <b>TACHOMETER</b>                | <b>RPM</b>   | 850                  | 850-2750                |                      | 2750                 |
| <b>CYLINDER HEAD TEMP. (CHT)</b> |              | 240° F               |                         |                      | 525° F               |
| <b>OIL TEMPERATURE</b>           | <b>°F</b>    | 75° F                |                         | 200° F               | 225° F               |
| <b>FUEL PRESSURE</b>             | <b>PSI</b>   | .5                   | 3 - 8                   | 8                    | 8                    |
| <b>OIL PRESSURE</b>              | <b>PSI</b>   | 10                   | 30-60                   |                      | 60                   |
| <b>VOLTMETER</b>                 | <b>VOLTS</b> |                      | 10 - 14                 |                      |                      |

# ZODIAC XL-SLSA WITH 0-200 ENGINE

---

## LIMITATION PLACARDS

The following placards are installed:  
Instrument panel area:

THIS AIRCRAFT WAS MANUFACTURED IN ACCORDANCE WITH LIGHT SPORT AIRCRAFT AIRWORTHINESS STANDARDS AND DOES NOT CONFORM TO STANDARD CATEGPRY AIRWORTHINESS REQUIRMENTS

Above placard must be posted in the aircraft passenger area so that it is visible to both the pilot and passenger upon entry or when seated in the aircraft

No Intentional Spins Warning: **NO INTENTIONAL SPIN**

Other placards on instrument panel:

**NO SMOKING**

Registration -----

**THROTTLE PULL CLOSE**

**MIXTURE PULL RICH**

**CARB. HEAT PULL OPEN**

Other placards in cabin area:

**TRIM  
NOSE UP**

**TRIM  
NOSE DOWN**

**FLAP  
UP**

**FLAP  
DOWN**

**SECTION 9**  
**ZODIAC XL-SLSA WITH 0-200 ENGINE**

---

- Baggage area:

Install rear of rear baggage area and at each wing locker if installed:

18kg/ 40 LBS MAX. SOFT ARTICLES ONLY  
CHECK WEIGHT AND BALANCE

- Right forward fuselage:

FUEL DRAIN ↘

- Rear left side fuselage:

Model: CH 601 XL SLSA  
MFG: AMD  
SERIAL #  
MFG DATE:

**WING TANKS Placards**

- At fuel gauges on instrument panel:

Left Usable  
14 US gal

Right Usable  
14 US gal

- Beside the wing tank fillers:

AVIATION FUEL  
80/87

- Radio master breaker

RADIO  
MASTER  
BKR

**SECTION 10**

**SUPPLEMENTARY INFORMATION**

**SAMPLE**

**SECTION 10**

**SUPPLEMENTARY INFORMATION**

**INTRODUCTION**

This section provides a supplementary information of the airplane and its systems and their operation.

**THE AIRPLANE**

The ZODIAC is a single-engine, fixed gear, low wing monoplane of all metal construction. It has side by side seating for two with dual flight controls.

**AIRFRAME**

The primary structure, with the exception of the steel tube engine mount, steel nose gear strut, and isolated areas, is of 6061-T6 aluminum sheet metal riveted to aluminum extrusions with Avex rivets. Composites are used on non-structural fairings.

The fuselage is a conventional semi-monocoque structure. A large forward-tilting acrylic canopy provides easy access from either side. The rear baggage area is accessible through the cabin.

The main wings have a high lift airfoil and Hoerner wing tips to maximize the ZODIAC's effective wing span. The cantilever wings are attached to each side of the fuselage by insertion of the butt ends of the main spars into a center spar structure which is an integral part of the fuselage. The center spar structure, located under the seat, in effect provides a continuous main spar with splices at each side of the fuselage. The fore and aft wing attachment points introduce wing torsion and shear forces into the fuselage.

## **INSTRUMENT PANEL CONTROLS**

### **INSTRUMENT PANEL**

The instrument panel is designed to accommodate the standard instruments for VFR flights, with plenty of room to install optional avionics and instruments.

**SAMPLE**

## SECTION 10

### ZODIAC XL-SLSA WITH 0-200 ENGINE

---

#### FLIGHT CONTROLS

Dual flight controls are provided as standard equipment. The flight controls actuate the control surfaces through a combination of push-pull rods and cables.

The horizontal tail is comprised of a fixed stabilizer and a movable elevator. The elevator is operated by moving the stick forward and aft. An electrically operated trim tab is mounted on the trailing edge of the elevator. This tab provides trim control by activation of a switch located on the pilots stick.

The rudder is an all-flying rudder and is operated by conventional foot pedals.

The ailerons are conventional in design and are operated by moving the stick control from side to side. Optional aileron trim tab is available and operated by a switch on the pilots stick.

The flaps are electrically actuated by a switch on the instrument panel. Flap position is monitored by the flap position indicator, close to the switch.

#### ENGINE CONTROLS

Engine controls consist of a throttle, a mixture, and a carb. Heat “push pull” control. These controls are located at the lower center of the instrument panel where they are accessible to both pilot and co-pilot.

The “**Black Handled**” throttle control is used to adjust engine RPM. Springs are added to the throttle lever arm to ensure that the engine will go to full power if linkages should fail.

The “**Red Handled**” mixture control is used to adjust the air-to-fuel ratio. The engine is shut down by the placing of the mixture control in the full lean position. In addition, the mixture control has a push button lock to prevent inadvertent activation of the mixture control. For more information on the leaning procedure, see the Engine Operator’s Manual.

The carburetor heat control has two positions: pull out for ‘ON’, push in for ‘OFF’.

**SECTION 10**  
**ZODIAC XL-SLSA WITH 0-200 ENGINE**

---

**LANDING GEAR**

The fixed gear ZODIAC is equipped with 3 – 5.00 x 5 wheels. Single disc hydraulic brake assemblies are provided on the main gear. The main gear shock absorber is a one piece metal leaf spring.

The nose gear is steerable by the use of rudder pedals. A shock-chord (bungee) assembly on the nose strut dampens shocks and bumping during taxiing.

The brakes are actuated by toe brake pedals which are attached to the rudder pedals. The master cylinders are connected to the pedals on the pilot (left) side, and slave cylinders are on the passenger side (optional).

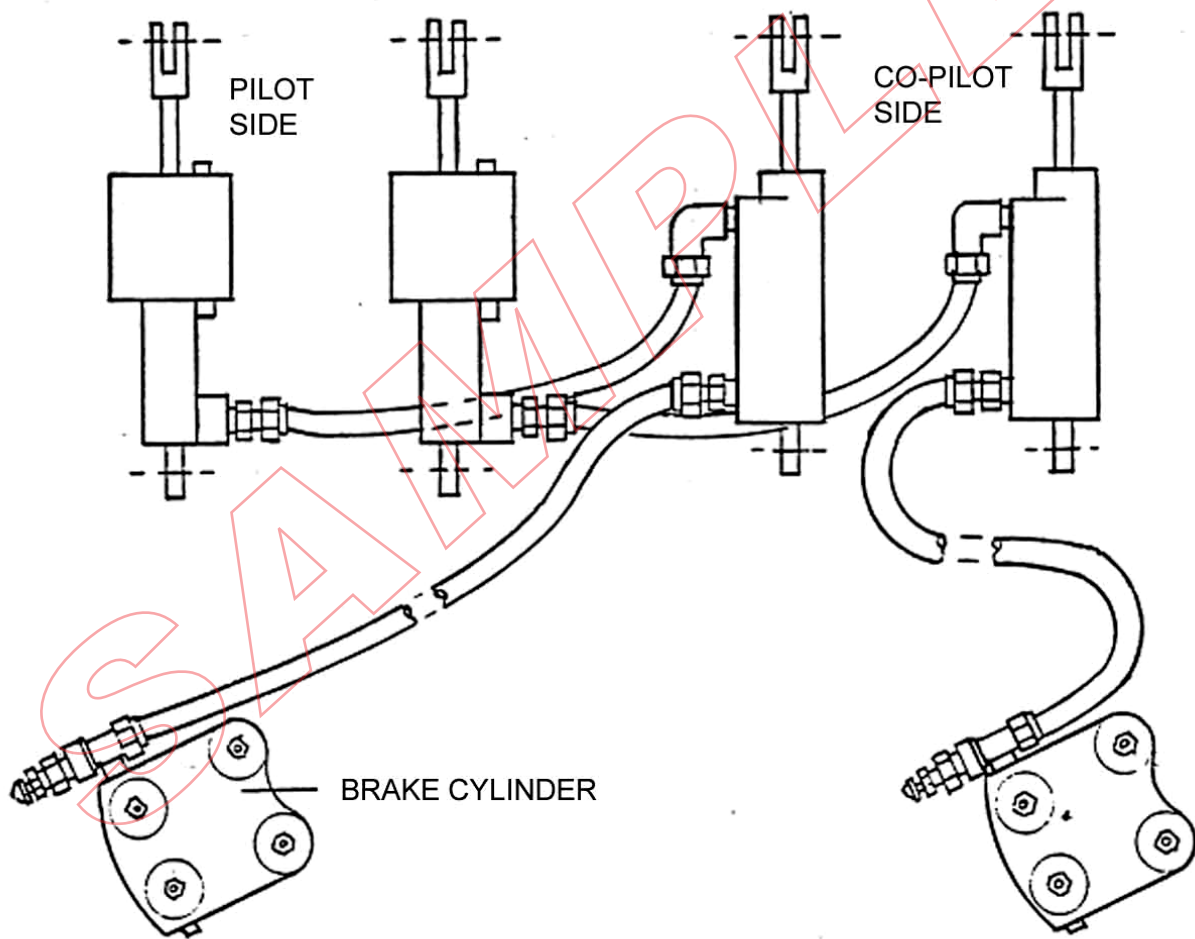

**BRAKE SYSTEM**



**SECTION 10**  
**ZODIAC XL-SLSA WITH 0-200 ENGINE**

---

**POWERPLANT AND PROPELLER**

The ZODIAC is powered by a four cylinder horizontally opposed Continental 0-200 air cooled engine

The engine compartment is accessible for inspection by removing the fasteners from the top and bottom cowling. The engine mount is constructed of steel tubing, and attachment is provided to reduce vibrations.

The exhaust system is constructed of stainless steel and incorporates heater shrouds to supply heated air for the cabin and carb heat.

The engine is air cooled by directing air around the cylinder fins with a baffling system.. Air for the muffler shrouds is also picked up from the nose cowling and carried through a duct to the shrouds. Heated air enters the carburetor air box through a hose connected to the heater shroud.

A fixed pitch propeller with leading edge protection is installed as standard equipment.

The pilot should read and follow the procedures recommended in the Engine Operator's Manual for this engine in order to obtain maximum engine efficiency and time between engine overhauls.

**FUEL SYSTEM**

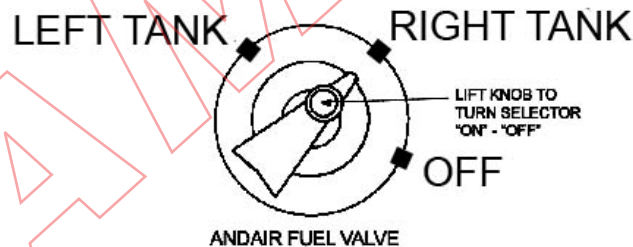

**FUEL SELECTOR**

The fuel is stored in a Right and Left wing tanks , capacity 2 x 15 US gallons (2 x 14 US gallons usable).

The fuel tank selector control is located on the seat center panel between the pilot and passenger. The handle points forward Right for right tank, forward Left for left tank.

## SECTION 10

### ZODIAC XL-SLSA WITH 0-200 ENGINE

An auxiliary electric fuel pump is provided in case of failure of the engine driven pump. The electric pump should be ON for all takeoffs and landings (and when switching tanks). The fuel pump switch is located on the instrument panel.

The fuel drains must be opened daily prior to first flight to check for water or sediment. Each tank has an individual drain. Check that the drains do not leak, after closing them.

The gascolator located under the fuselage, near the firewall, must also be drained before the first flight of the day.

Fuel quantity and fuel pressure gauges are mounted on the instrument panel.

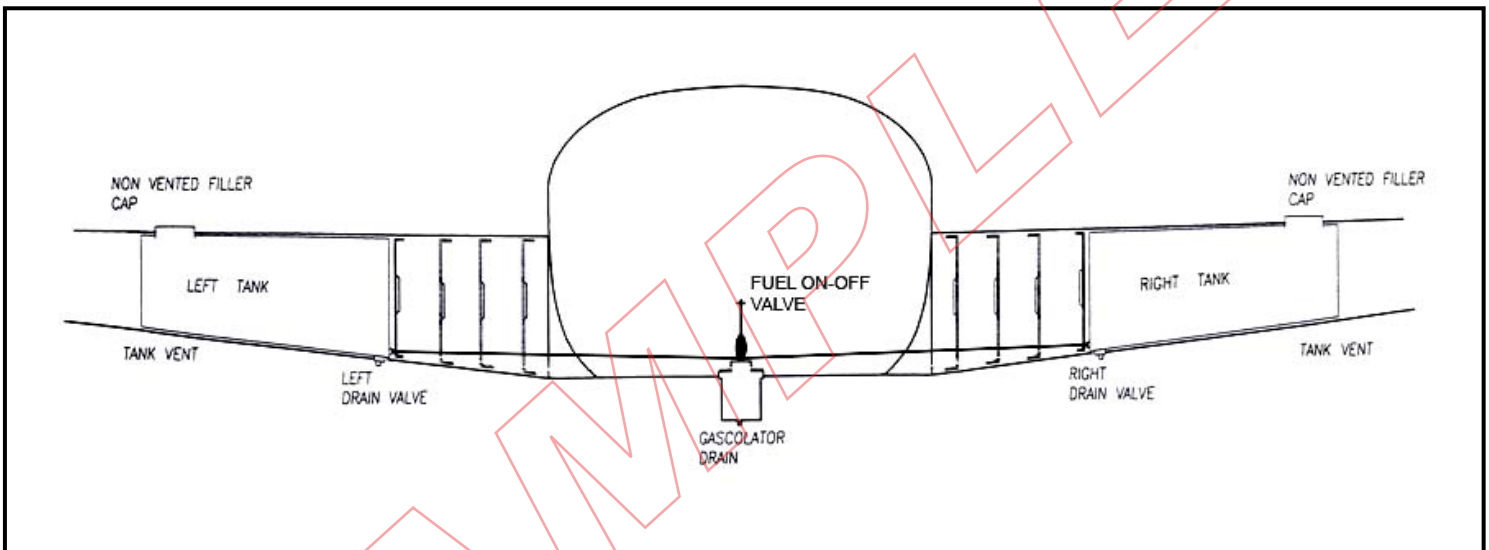

**FUEL SYSTEM SCHEMATIC**

## ELECTRICAL SYSTEM

The electrical system includes a 14 volt alternator, voltage regulator, battery contactor and a standard 12 volt battery. The battery is mounted at the firewall, with the master switch solenoid just above the battery. The voltage regulator is on the firewall. The master switch and other electrical switches are located on the instrument panel.

Standard electrical accessories include a starter, an electric fuel pump, fuel gauge, and Volt Meters.

The system also provides for such optional electrical accessories as additional lights and gauges, and communication and navigational equipment.

The master switch is an on/off toggle switch with a breaker. The alternator has a breaker switch, and the field has an on/off toggle switch. They are located on the lower left of the instrument panel.

**SECTION 10**  
**ZODIAC XL-SLSA WITH 0-200 ENGINE**

---

**PITOT-STATIC SYSTEM**

The system supplies both pitot and static pressure for the airspeed indicator, altimeter, and the optional vertical speed indicator.

Pitot and static pressure are picked up by a pitot head installed on the bottom of the left wing and carried through pitot and static lines within the wing and fuselage to the gauges on the instrument panel.

To prevent bugs from entering the pitot and static pressure holes, a cover should be placed over the pitot head, when the aircraft is not in use. A partially or completely blocked pitot head will give erratic or zero readings on the instruments.

**NOTE**

During the preflight, check to make sure the pitot cover is removed.

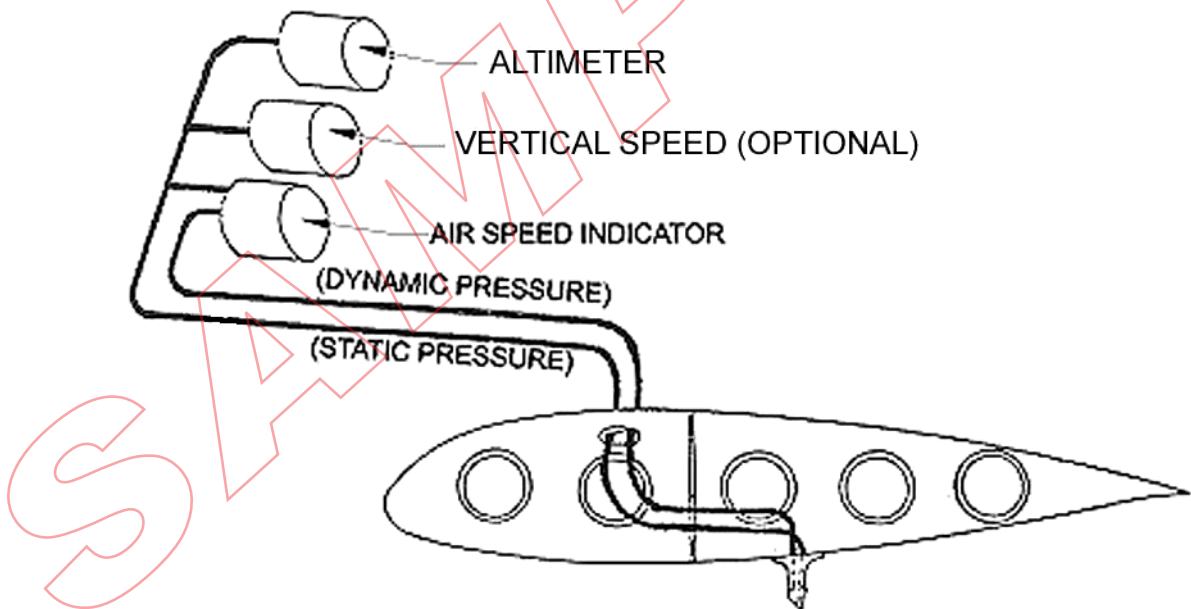

**PITOT-STATIC SYSTEM VFR**

**SECTION 10**  
**ZODIAC XL-SLSA WITH 0-200 ENGINE**

---

**HEATING AND VENTILATION SYSTEM**

Heat for the cabin interior is provided by a shroud surrounding to the muffler. Heat is regulated with the control located on the instrument panel.

Fresh air is directed into the cabin through the vents installed in the right and left front fuselage sides.

**WARNING:** Canopy must be closed securely when engine is on.

**PROPELLER SPINNER**

Airplane may be used with the spinner removed.

SAMPLE

**SECTION 11**

**OPTIONS**

SAMPLE

**SECTION 11**

**OPTIONS**

**GENERAL**

This section provides additional necessary information for the efficient operation of the airplane when equipped with one or more of the various optional equipment and/or systems not provided with the standard airplane.

All of the Options provided by this section are “Approved” options, and consecutively numbered as a permanent part of this Pilot Operating Handbook. The information contained in each Option applies only when the related equipment is installed in the airplane. No change to limitations or performance is associated with these options.

Your aircraft may be equipped with avionics, an EFIS, an EMS, auto pilot etc. Operation of these items is detailed in the manufacturer’s instructions and are for VER only. Note that manufacturers operating instructions that can be downloaded from their web sites. Owner / operator of the aircraft must add these instructions to this POH and must keep them updated.

## SECTION 11

### ZODIAC XL-SLSA WITH 0-200 ENGINE

---

#### EMERGENCY LOCATOR TRANSMITTER (E.L.T.)

##### GENERAL

The E.L.T. consists of a self-contained dual-frequency radio transmitter and battery power supply, and if ARMED, it is activated by an impact producing a change in velocity of 3.5 ft/sec. or more as may be experienced in a crash landing. The E.L.T. emits an omni-directional signal on the international distress frequencies of 121.5 and 243.0 MHz. General aviation and commercial aircraft, the FAA, and CAP monitor 121.5 MHz, and 243.0 MHz is monitored by the military. Following a crash landing, the E.L.T. will provide line-of-sight transmission up to 100 miles at 10,000 feet. The E.L.T. transmits on both distress frequencies simultaneously at 75 mw rated power output for 48 continuous hours in the temperature range of -4°F to +131°F (-20°C to +55°C).

The portable E.L.T. unit is mounted behind the rear co-pilot seat. An ON-OFF switch is mounted on the instrument panel for activation and /or deactivation. The E.L.T. can also be activated or deactivated by moving the toggle switch in the unit.

##### EMERGENCY PROCEDURES

Immediately after a forced landing where emergency assistance is required, the E.L.T. should be utilized as follows.

1. Ensure E.L.T. Activation - Turn a radio transceiver ON and select 121.5 MHz. If the E.L.T. can be heard transmitting, it was activated by the "g" switch and is functioning properly. If no emergency tone is audible, push the switch to ON.
2. Prior To Sighting Rescue Aircraft - Conserve airplane battery. Do not activate radio transceiver.
3. After Sighting Rescue Aircraft - Switch E.L.T. to OFF, preventing radio interference. Attempt contact with rescue aircraft with the radio transceiver set to a frequency of 121.5 MHz. If no contact is established, push the E.L.T. switch to ON immediately.
4. Following Rescue - Push the switch to ARMED.

##### NORMAL PROCEDURES (E.L.T.)

As long as the function selector switch remains in the ARMED position, the E.L.T. automatically activates following an impact.

Following a lightning strike, or an exceptionally hard landing, the E.L.T. may activate although no emergency exists. To check your E.L.T. for inadvertent activation, select 121.5 MHz. on your radio transceiver and listen for an emergency tone transmission. If the E.L.T. can be heard transmitting, push the switch to OFF, then to ARMED for normal operation.

**NEVER ACTIVATE the ELT while airborne for any reason.**

## **SECTION 11**

### **ZODIAC XL-SLSA WITH 0-200 ENGINE**

---

#### **ELT MAINTENANCE**

Refer to the ELT Operation Manual. (Battery replacement).

#### **FIRE EXTINGUISHER**

The fire extinguisher is mounted behind the co-pilot, in the baggage area. It is to be used and maintained as per instructions printed on the unit.

#### **TOW BAR**

The tow bar is not stored in the aircraft.

#### **WHEEL FAIRINGS**

The wheel fairings give a sleek look to your aircraft with little change in performance. They are made of fiberglass and are easily removed or mounted to their attachment brackets.

Note: In snowy conditions, remove the wheel fairings so that the snow cannot accumulate inside, freeze and then lock the wheels.

#### **EXTERNAL POWER PLUG**

The external power plug is a typical type "Piper aircraft" plug. Do not reverse the polarity as this will cause damage to the electric system.

#### **STALL WARNING SYSTEM**

Stall warning system is to provide audible warning of an approach to aerodynamic stall. The system consists of an electric switch on the leading edge of the right wing and an electric horn in cabin. The warning sounds at approximately 5 knots above stall with full flaps and power off in wings level flight and at slightly greater margins in turning and accelerated flight. With battery power on, the stall warning system preflight check is accomplished as follows:

Stall warning system preflight check:

1. Turn master switch to ON position
2. Move switch up with hand carefully. Horn must sound.

#### **WARNING:**

Stall switch may bend due to poor ground handling. Warning sound in flight will then sound at a different speed.



**SECTION 12**

**FAMILIERIZATION FLIGHT PROCEDURES**

**SAMPLE**

**SECTION 12**

**FAMILIERIZATION FLIGHT PROCEDURES**

**WARNING:**

Familiarization flight procedures in this manual are not intended for "self-check out".

**No-"self-check out" is permitted. A check ride with a sport pilot familiar with and having operated the airplane, or a check ride with a certified sport pilot CFI or CFI Examiner or Factory Pilot is required.**

For Aircraft Flight Training Supplement, this manual covers the basics. A supplemental manual is available on CD ROM.

## **Supplement Number 1**

**Model: Zodiac XL**

# **NIGHT VFR FLYING**

### **EAA ARTICLE 10/13/05 - SPECIAL LSA AND NIGHT/IFR FLYING**

Some confusion exists in the aviation marketplace regarding the use of special light-sport aircraft (S-LSA) for flying at night and/or under instrument flight rules (IFR). The ASTM consensus standards that govern the manufacture and production of S-LSA specifically address day/visual flight rules (VFR) operations only.

First, sport pilots, or those exercising sport pilot privileges, are restricted from flying at night or in IFR conditions, so they may not operate an S-LSA, or any aircraft, at those times.

Other properly rated pilots may fly an S-LSA in those conditions if allowed per the aircraft's operating limitations and if it is equipped per FAR 91.205. Additionally, FAR 91.327(d) requires all S-LSA to be operated in accordance with the aircraft's operating instructions. An aircraft's operating instructions are different from operating limitations; operating instructions are issued by manufacturers-engine, airframe, and accessory-while operating limitations are issued by the FAA.

Many S-LSA are equipped with Rotax engines. Rotax's operating instructions prohibit the use of a Rotax engine at night or in IFR conditions unless it is the FAA type-certificated engine; that is, certificated to FAR Part 33. Rotax's non-certificated engines are indicated by the letters "UL" after the engine series number; for example, 912UL, 912ULS, and 914UL.

Additionally, S-LSA airframe and engine manufacturers may place restrictions against the use of their aircraft and/or engines for night/IFR operations. For example, other S-LSA are powered by Jabiru engines; these engines are certificated to JAR-22H and are limited to day/VFR operation.

Bottom line: some S-LSA can be equipped for night and IFR operation; be sure to tell the manufacturer/dealer if your intent is to operate the aircraft under those conditions...and make sure you have the proper ratings.

For more information, call EAA's Aviation Service at 888/EAA-INFO (322-4636) or e-mail [info@eaa.org](mailto:info@eaa.org).

**SUPPLEMENT #1 NIGHT VFR FLYING  
ZODIAC XL-SLSA WITH 0-200 ENGINE**

---

**SUPPLEMENT NUMBER 1  
LOG OF REVISIONS**

| <b>Revision Date</b> | <b>Revised Pages</b> | <b>Description of Revision</b> |
|----------------------|----------------------|--------------------------------|
| JAN 2006             | All pages            | Initial Issue                  |
|                      |                      |                                |
|                      |                      |                                |
|                      |                      |                                |
|                      |                      |                                |
|                      |                      |                                |

**SUPPLEMENT NUMBER 1  
List of Effective Pages**

| <b>Supplement<br/>Number 1</b> | <b>Page</b> | <b>Date</b> |
|--------------------------------|-------------|-------------|
|                                | 1           | JAN 2006    |
|                                | 2           | JAN 2006    |
|                                | 3           | JAN 2006    |
|                                | 4           | JAN 2006    |
|                                | 5           | JAN 2006    |

**SUPPLEMENT #1 NIGHT VFR FLYING  
ZODIAC XL-SLSA WITH 0-200 ENGINE**

**CAUTION**

The Zodiac is a single engine airplane. When the operating limitations and maintenance requirements are complied with, it has the high degree of reliability. Nevertheless, an engine failure is not completely impossible. For this reason, flights during the night, or above terrain which is unsuitable for a landing, constitute even more risk. It is therefore highly recommended to select flight times and flight routes such that this risk is minimized.

**NOTE**  
Supplement #1 is for NIGHT VFR only. Aircraft must be equipped with "MINIMUM EQUIPMENT LIST FOR NIGHT VFR"

**MINIMUM EQUIPMENT LIST FOR NIGHT VFR**

Minimum operating equipment. The following table lists the minimum equipment required. Additional minimum equipment for the intended operation may be required and also depends on the route to be flown.

|  | <b>DAY VFR</b>  | <b>NIGHT VFR</b>   |
|--|---|--|
| <b>Flight and Navigation Instruments</b>   | - airspeed indicator<br>- altimeter<br>- compass                          | - magnetic compass   |
| <b>Engine Instruments</b>                  | - fuel indicators<br>- integrated engine instrument                       | - ammeter<br>- voltmeter   |
| <b>Lighting</b>                            |   | - position lights<br>- strobe lights (anti collision lights)<br>- landing light<br>- Taxi light<br>- instrument lighting / cabin light<br>- flashlight |
| <b>Other operational minimum equipment</b> | - POH<br>- Registration<br>- C of A<br>- W&B and installed component list |  |
| <b>Placards</b>                            | - Section 9 of POH  | Supplement #1  |

**TYPES OF OPERATIONS**

The airplane is approved for the following operations when equipped in accordance with the prevailing regulations.

Day V.F.R.

Night VFR

Flight in known or forecast icing conditions is prohibited.

# SUPPLEMENT #1 NIGHT VFR FLYING ZODIAC XL-SLSA WITH 0-200 ENGINE

---

## OTHER LIMITATIONS.

### BATTERY CHARGE

Taking off for Night VFR with an empty battery is not permitted. The use of an external power supply for engine starting with an empty airplane battery is not permitted if the subsequent flight is intended to be a Night VFR flight. In this case the airplane battery must first be charged, and aircraft charging system must be working.

### OPERATION TIME OF ELECTRICAL EQUIPMENT

Following an alternator failure, it can be expected that the systems are supplied with power for half an hour if only essential equipment is left on.

### NAVIGATION LIGHTS AND STROBES

Conventional type navigation lights are located on the wing tips and the rudder. Strobe lights are also mounted on the wing tips. ON/OFF switches, found on the instrument panel are labeled (NAV LIGHTS), and (STROBES) respectively. The switches are ON in the up position.

Strobe lights must be turned off when taxiing in the vicinity of other airplanes, or during night flight through clouds, fog or haze.

### LANDING LIGHTS

Dual landing / taxi lights are mounted on the airframe. The ON/OFF switch for the landing / taxi lights is found on the instrument panel.

### CABIN LIGHT

Cabin light is located between the seats in baggage area. The light is a multi purpose light providing narrow spotlight or floodlight beam. Rotate dial for red or white lens. Push-button for instant full light. Adjustable rheostat. Coiled cord & snap-in mounting makes light portable in cockpit area. Cabin light is not connected through the aircraft master switch and must therefore be turned off independently.



**SUPPLEMENT #1 NIGHT VFR FLYING  
ZODIAC XL-SLSA WITH 0-200 ENGINE**

---

**NIGHT VFR PLACARDS**

DAY AND NIGHT VFR  
IN NON-ICING CONDITIONS

LANDING  
LIGHT

TAXI  
LIGHT

STROBE  
LIGHTS

NAV  
LIGHTS

LIGHTS  
MASTER  
BKR

Above placards are added to aircraft in addition to standard placards in section 9.

## Supplement Number 2

Model: ZODIAC *XLi*

# IFR

### CAUTION

The Zodiac is a single engine airplane. When the operating limitations and maintenance requirements are complied with, it has the high degree of reliability. Nevertheless, an engine failure is not completely impossible. For this reason, flights during the night, in IFR conditions, or above terrain which is unsuitable for a landing, constitute even more risk. It is therefore highly recommended to select flight times and flight routes such that this risk is minimized.

### NOTE

For the upgrade of an airplane for IFR operation, it is not sufficient to install the required equipment. The upgrade must be carried out by the manufacturer. Your aircraft model must be the *Zodiac Xli*.

### EAA ARTICLE 10/13/05 - SPECIAL LSA AND NIGHT/IFR FLYING

Some confusion exists in the aviation marketplace regarding the use of special light-sport aircraft (S-LSA) for flying at night and/or under instrument flight rules (IFR). The ASTM consensus standards that govern the manufacture and production of S-LSA specifically address day/visual flight rules (VFR) operations only.

First, sport pilots, or those exercising sport pilot privileges, are restricted from flying at night or in IFR conditions, so they may not operate an S-LSA, or any aircraft, at those times.

Other properly rated pilots may fly an S-LSA in those conditions if allowed per the aircraft's operating limitations and if it is equipped per FAR 91.205. Additionally, FAR 91.327(d) requires all S-LSA to be operated in accordance with the aircraft's operating instructions. An aircraft's operating instructions are different from operating limitations; operating instructions are issued by manufacturers-engine, airframe, and accessory-while operating limitations are issued by the FAA.

Many S-LSA are equipped with Rotax engines. Rotax's operating instructions prohibit the use of a Rotax engine at night or in IFR conditions unless it is the FAA type-certificated engine; that is, certificated to FAR Part 33. Rotax's non-certificated engines are indicated by the letters "UL" after the engine series number; for example, 912UL, 912ULS, and 914UL.

Additionally, S-LSA airframe and engine manufacturers may place restrictions against the use of their aircraft and/or engines for night/IFR operations. For example, other S-LSA are powered by Jabiru engines; these engines are certificated to JAR-22H and are limited to day/VFR operation.

Bottom line: some S-LSA can be equipped for night and IFR operation; be sure to tell the manufacturer/dealer if your intent is to operate the aircraft under those conditions...and make sure you have the proper ratings.

For more information, call EAA's Aviation Service at 888/EAA-INFO (322-4636) or e-mail [info@eaa.org](mailto:info@eaa.org).



**SUPPLEMENT NUMBER 2**  
**LOG OF REVISIONS**

| <b>Revision Date</b> | <b>Revised Pages</b> | <b>Description of Revision</b> |
|----------------------|----------------------|--------------------------------|
| JAN 2006             | All pages            | Initial Issue                  |
|                      |                      |                                |
|                      |                      |                                |
|                      |                      |                                |
|                      |                      |                                |
|                      |                      |                                |

**SUPPLEMENT NUMBER 2**  
**List of Effective Pages**

| <b>Supplement Number 1</b> | <b>Page</b> | <b>Date</b> |
|----------------------------|-------------|-------------|
|                            | 1           | JAN 2006    |
|                            | 2           | JAN 2006    |
|                            | 3           | JAN 2006    |
|                            | 4           | JAN 2006    |
|                            | 5           | JAN 2006    |
|                            | 6           | JAN 2006    |
|                            | 7           | JAN 2006    |
|                            | 8           | JAN 2006    |

**OTHER LIMITATIONS**

**BATTERY CHARGE**

Taking off for a Night VFR and or IFR with an empty battery is not permitted. The use of an external power supply for engine starting with an empty airplane battery is not permitted if the subsequent flight is intended to be a Night VFR and or IFR flight. In this case the airplane battery must first be charged, and aircraft charging system must be working.

**OPERATION TIME OF ELECTRICAL EQUIPMENT**

Following an alternator failure, it can be expected that the systems are supplied with power for half an hour if only essential equipment is left on.

After this, electrical power is available for the attitude gyro (artificial horizon) and flood light for another 1 hour when the back-up battery is used.

**WARNING**

Autopilots and Multi Function Displays that may be installed in your aircraft are not IFR approved and therefore may not be used when flying IFR. GPS use for IFR flight requires an IFR approved GPS. Gyros which are TSO are the primary flight instruments. TSO NAV equipment must be used when flying in IFR conditions.

**WARNING**

Neither the flying surfaces nor the propeller are equipped with deicing devices, IFR flight into known or forecast icing conditions is prohibited.

**SUPPLEMENT #2 IFR**  
**ZODIAC Xli -SLSA WITH 0-200 ENGINE**

The airframe is approved for IFR when properly equipped by the manufacturer.

**MINIMUM EQUIPMENT LIST FOR IFR**

Minimum operational equipment. The following table lists the minimum equipment required. Additional minimum equipment for the intended operation may be required and also depends on the route to be flown.

|  | <b>DAY VFR</b>  | <b>NIGHT VFR</b>   | <b>IFR</b>   |
|--|---|--|--|
| <b>Flight and Navigation Instruments</b>   | - airspeed indicator<br>- altimeter<br>- compass                          | - magnetic compass   | - vertical speed indicator sensitive<br>- attitude gyro (artificial horizon) TSO<br>- turn & bank indicator<br>- directional gyro TSO<br>- OAT indicator<br>- clock with indication of hours, minutes, and seconds<br>- VHF radio (COM) TSO<br>- VOR receiver and or GPS TSO / IFR certified by FAA<br>- transponder (XPDR) mode C TSO<br>-1 headset |
| <b>Engine Instruments</b>                  | - fuel indicators<br>- integrated engine instrument                       | - ammeter<br>- voltmeter   |  |
| <b>Airframe / Engine</b>                   |   |  | Airframe model: Zodiac Xli (see data plate on fuselage side)<br>Engine: FAR 33 certified (see data plate on engine)  |
| <b>Lighting</b>                            |   | - position lights<br>- strobe lights (anti collision lights)<br>- landing light<br>- Taxi light<br>- instrument lighting / cabin light<br>- flashlight |  |
| <b>Other operational minimum equipment</b> | - POH<br>- Registration<br>- C of A<br>- W&B and installed component list |  | - pitot heating system<br>- alternate static valve<br>- lightning protection<br>- de-icing window<br>- Electrical battery back-up<br>- Second electric bus system with master switch   |
| <b>Placards</b>                            | - Section 9 of POH  | Supplement #1  | Supplement #2  |

Minimum equipment includes all items in DAY VFR column, NIGHT VFR column, and IFR column.

**TYPES OF OPERATIONS**

The airplane model Zodiac XLi is approved for the following operations when equipped in accordance with the prevailing regulations.

Day V.F.R.

Night VFR - IFR

Flight in known or forecast icing conditions is prohibited.

**SUPPLEMENT #2 IFR**  
**ZODIAC Xli -SLSA WITH 0-200 ENGINE**

---

Detailed procedures to check the instruments, navigational aids and radios are given in the operation instruction for the relevant equipment. These instructions must be added to this supplement by the pilot / owner and must be kept up-to-date.

- 1) Should the Airspeed indicator, the altimeter and the rate of climb stop giving information, the pitot static probe is frozen up. The pitot heat switch is then moved up to "ON", which will melt the accumulated ice.

If this is not effective, the static source switch is moved down to Alternate. This will open the static to the cabin pressure: Altimeter and rate of climb will give readings.

With the alternate static, the Altitude must be corrected as follows:

|   |  |
|---|--|
| Alternate static 'ON',<br>deicing window closed,<br><br>cabin heat off or on: | Subtract 100 feet from<br>indicated altitude |
| Alternate static "ON",<br>deicing window open,<br><br>cabin heat off or on:   | Subtract 190 feet from<br>indicated altitude |

The rate of climb indications are correct.

If the pitot static probe is frozen, the airspeed will not read: Rate of climb and RPM are then the sole indications to the pilot for an approximation of the speed. If only the static is frozen (not the pitot), and the alternate static is on, use following indicated airspeeds:

Climb and approach at 75 KIAS  
Stall will occur at 55 KIAS (flaps up) and 50 KIAS (flaps down)  
(in cruise KIAS = KCAS + 15 kts)

Note: The GPS (Ground Positioning Satellites) speed reading may come in quite handy at this stage.

- 2) Should the windshield start icing: Pull cabin heat: the left part of the windshield will defrost. If this is ineffective, the deicing window must be opened and the ice covering the left side of the windshield manually removed. The deicing window is positioned so that landings can be performed looking through it at the runway and left edge of the runway.

## **GYROS**

### **ATTITUDE GYRO (artificial horizon) - ELECTRICAL**

Gives a visual indication of flight attitude. Bank attitude is presented by a pointer at the top of the indicator relative to the bank scale which has index marks at 10°, 20°, 30°, 60°, and 90° either side of the center mark. Pitch and roll attitudes are presented by a miniature airplane superimposed over a symbolic horizon area divided into two sections by a white horizon bar. The upper "blue sky" area and the lower "ground" area have arbitrary pitch reference lines useful for pitch attitude control. A knob at the bottom of the instrument is provided for inflight adjustment of the miniature airplane to the horizon bar for a more accurate flight attitude indication.

### **DIRECTIONAL GYRO - ELECTRICAL**

Displays airplane heading on a compass card in relation to a fixed simulated airplane image and index. The directional indicator will process slightly over a period of time. Therefore, the compass card should be set just prior to takeoff, and occasionally re-adjusted on extended flights. A knob on the lower left edge of the instrument is used to adjust the compass card to correct for any precession.

### **TURN AND BANK GYRO - ELECTRICAL**

Gives in flight turn and bank coordination information. Found at the lower left of the instrument panel cluster.

#### **WARNING**

Do not use gyro when power out warning indicator is visible.

## **WINDSHIELD DEFROST**

Pull cabin heat control full out to obtain maximum air temperature. IFR airframe has small windshield defroster when cabin heat is pulled.

## **ALTERNATE STATIC**

Alternate static switch is located on the instrument panel.

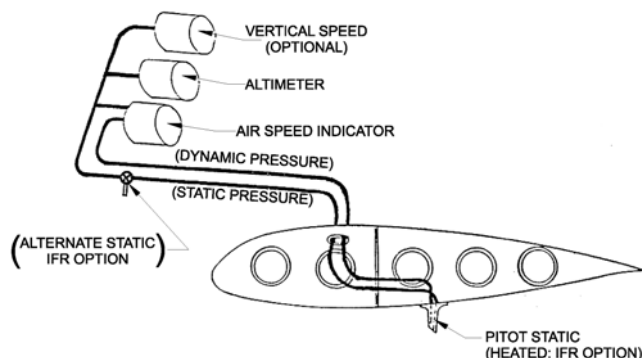

### **OUTSIDE AIR TEMPERATURE GAUGE**

Aircraft is equipped with an outside air temperature gauge located on the instrument panel.

### **HEATED PITOT**

Aircraft is equipped with a heated pitot. Electric switch is located on the instrument panel.

### **DE-ICING WINDOW**

Aircraft is equipped with a pilot side storm window.

### **BACK-UP ELECTRICAL SYSTEM**

Aircraft in IFR is equipped with a rechargeable back-up battery system. The battery when fully charged will deliver more than 1 hour to your IFR Buss, when **ONLY** the essential electrics are being used.

### **IFR BUSS**

Avionics master switch controls the IFR bus. This bus supplies power to the following items:

- NAV/COM #1, TRANSPONDER, ENCLODER
- IFR GPS (if installed)
- ATTITUDE GYRO (artificial horizon)

**SUPPLEMENT #2 IFR**  
**ZODIAC *Xli* -SLSA WITH 0-200 ENGINE**

---

**IFR MARKINGS:**

DAY AND NIGHT VFR OR IFR  
IN NON-ICING CONDITIONS

PITOT  
HEAT

NORMAL  
STATIC SOURCE  
ALTERNATE

VFR USE ONLY

This label is added to non TSO type instruments and or non IFR FAA certified NAV equipment such as basic GPS.

- Compass deviation chart

Above placards are added to aircraft in addition to standard placards in section 9 and supplement #1 for night option.

SAMPLE

## Supplement Number 3

Model: Zodiac XL

# USE OF AUTOMOBILE GASOLINE

### USE OF AUTOMOTIVE GASOLINE IN TCM AIRCRAFT ENGINES

Teledyne Continental Motors would like to remind its customers that the use of automotive fuels in TCM aircraft engines not only represents a potential safety of flight concern, but can also significantly affect cylinder life and durability.

Engines produced by TCM are FAA certificated to a minimum grade of fuel conforming to ASTM D910 - grade 100LL or 100 aviation gasoline. Early engine models such as the O-200, O-300, and O-470 series are certificated to grade 80 aviation gasoline, also conforming to ASTM D910. Detonation margins, compression ratio, rated power, engine cooling, fuel schedules, ignition timing, and fuel system vapor handling are established and FAA certificated based upon use of a fuel conforming to ASTM D910. The use of any fuel not conforming to ASTM D910 may compromise safety and/or result in significant mechanical difficulties.

Automotive gasoline is manufactured to the industry specification ASTM D4814 which does not control or establish limits for octane rating, major anti-knock constituents, or energy density (lower heating value). In addition, critical properties such as vapor pressure and level of contaminants are not tightly controlled as with AVGAS. Vapor characteristics for auto gas are inferior to AVGAS and result in a tendency for auto gas to more readily convert to vapor. In addition, the lower octane rating of auto fuel can lead to detonation and pre-ignition which may damage the engine. Alcohol content of auto fuels may also result in damage to o-rings, seals, and other elastomer components in the fuel system.

It is important to note that automotive gasolines are not subject to the high level of quality control applied to AVGAS. The allowable concentrations of additives, contaminants, and water in AVGAS are precisely controlled by ASTM D910. Automotive gasolines within the United States are changing rapidly to meet ever more demanding environmental regulations. Fuel producers have advised that auto gas will be subject to continuing changes in the future, with additive formulas varying widely. Current Federal and State laws allow properties of automotive gasoline to vary seasonally and geographically. Some states do not even require that automotive gasoline conform to the ASTM D4814 industry standard.

Current aircraft engines feature valve gear components which are designed for compatibility with the leaded ASTM D910 fuels. In such fuels, the lead acts as a lubricant, coating the contact areas between the valve, guide, and seat. The use of unleaded auto fuels with engines designed for leaded fuels can result in excessive exhaust valve seat wear due to the lack of lead. The result can be remarkable, with cylinder performance deteriorating to unacceptable levels in under 10 hours.

Field experience has determined the use of unleaded automotive gasoline to be the cause of premature cylinder replacement due primarily to rapid and severe valve seat recession. Therefore, if you choose to operate your engine on automotive gasoline, valve seat and guide wear may occur at an accelerated rate. TCM strongly advises against the use of such fuels for reliability and safety reasons. **Because of this, engine or parts warranty will be voided where such fuels are used.**

TCM understands the high cost of flying and is committed to the relentless pursuit of product improvements leading to improved cost effectiveness. Unleaded aviation gasoline and next generation cylinder components are integral to our strategic plan for that future. In the interim, we ask you to consider the adage of "...penny wise..." when considering the use of automotive fuels in your aircraft engine.

Copied from Teledyne Technologies Incorporated May 2006



**SUPPLEMENT #3 USE OF AUTOMOBILE GASOLINE  
ZODIAC XL-SLSA WITH 0-200 ENGINE**

---

**SUPPLEMENT NUMBER 1  
LOG OF REVISIONS**

| <b>Revision Date</b> | <b>Revised Pages</b> | <b>Description of Revision</b> |
|----------------------|----------------------|--------------------------------|
| MAY 2006             | All pages            | Initial Issue                  |
|                      |                      |                                |
|                      |                      |                                |
|                      |                      |                                |
|                      |                      |                                |
|                      |                      |                                |

**SUPPLEMENT NUMBER 1  
List of Effective Pages**

| <b>Supplement<br/>Number 3</b> | <b>Page</b> | <b>Date</b> |
|--------------------------------|-------------|-------------|
|                                | 1           | MAY 2006    |
|                                | 2           | MAY 2006    |
|                                | 3           | MAY 2006    |
|                                | 4           | MAY 2006    |
|                                | 5           | MAY 2006    |

**SUPPLEMENT #3 USE OF AUTOMOBILE GASOLINE  
ZODIAC XL-SLSA WITH 0-200 ENGINE**

---

Note: EAA aviation foundation has an STC for the Cessna 150 with Continental 0-200 engine. Peterson Aviation Inc. also has an STC for the Cessna 150 with Continental 0-200 engine. It has therefore been well proven that the 0-200 engine works well with automobile gasoline. The Zodiac airframe has over 20 years of field history on automobile gasoline. In Europe and in the USA, hundreds of Zodiac aircraft are equipped with the Rotax 912UL which runs on automobile gasoline. In addition to this, AMD has successfully completed its own tests.

Note: Required by law in many states, it must be noted that it is the pilot in command's responsibility to insure that the fuel meets the specifications. It is recommended that the pilot uses gasoline from known and reliable suppliers and especially to observe precautions against fueling the airplane with contaminated fuel.

**WARNING: Do not use gasoline that contains alcohol.**

Note: In order to make sure that there is no alcohol in the gasoline, test the gasoline before putting it in the aircraft tanks. See EAA "Field test for determining presence and amount of alcohol in gasoline" at <http://www.eaa.org/education/fuel/oxygenated.html> or contact Peterson Aviation for a tester.

The Zodiac XL with 0-200 engine is approved for automobile gasoline when the following is complied to:

- 1, This flight manual supplement must be added to the standard POH.
- 2, Install placards regarding approved fuels on the wing close to the fuel tank inlet, left and right wings.

Note: Be sure that the gallon capacity of each tank is labeled as required.

- 3, The **HODGES VOLATILITY TESTER** must be used in accordance with the instructions supplied with the **HODGES VOLATILITY TESTER**.

**WARNING: Fuel must pass the HODGES VOLATILITY TESTER.**  
Use before take off when outside air temperature exceeds 70 deg. F.

Note: Water is the principal contaminant of fuel. The actual contamination occurs through condensation (occurring in partially filled fuel tanks and in storage and dispensing facilities such as underground tanks and fuel truck tanks), and entry out of moisture (such as rain or snow entering through the vent system)

- 4, Drain fuel sumps at each preflight (and drain fuel screens to prevent water contamination).
- 5, After refueling, it is recommended waiting about 20 minutes because it may take that long for water to settle low enough to show up at the sumps. If this is not feasible, make takeoff on a tank that has not been added to.

6, Turn on auxiliary electric fuel pump before startup and leave on until cruising. Turn on before descending.

Note: On a new factory engine or newly overhauled engine, use 2-3 hours 100LL avgas before using autogas.

Note: After any prolonged period of heat soak, such as hot day ground idling or engine restart a short time after a long period of engine operation, perform a FULL POWER check before taking off. Ensure recommended fuel pressure is indicated within fuel pressure gauge limits (use up the hot fuel in the fuel line).

SAMPLE

**SUPPLEMENT #3 USE OF AUTOMOBILE GASOLINE  
ZODIAC XL-SLSA WITH 0-200 ENGINE**

---



984 K Road  
Minden, Nebraska 68959  
phone 308/832-2050  
fax 308/832-2200

**HODGES VOLATILITY TESTER**

The most important thing to consider when using auto fuel in aircraft concerns vapor pressure or volatility. The fact that approved engines operate quite well on auto fuel is not in dispute. But given the right set of circumstances **any** airplane can vapor lock. Until the Hodges tester was developed the only method of determining a fuel's vapor lock potential was to send a sample of fuel to a laboratory along with a substantial fee and wait patiently for six weeks to receive the results. This is of course totally impractical.

Thanks to Dr. Ray Hodges of Australia, a simple fail-safe portable tester is available. The Hodges Fuel Volatility Tester is small enough to be carried in the airplane and will tell you at a glance whether or not the fuel has any serious vapor lock potential, given the current outside air temperature. It immediately tells you if the fuel could cause vapor lock, regardless of contributing factors such as, temperature, altitude, seasonal blend, weathering history, or blends with avgas or ethanol. The operation of the tester is fail safe since air leaks cause low ("unsafe") readings.

This tester has become standard equipment for many people who use auto fuel and desire a preflight safety check of the fuel. Operating the tester is quick and simple. A sample of fuel is drawn into the syringe; the syringe is then coupled to the gage and the plunger is drawn down. This creates a vacuum in the syringe, the fuel boils, evaporates, and a reading is obtained on the gage which indicates whether the fuel is "safe or unsafe". Complete instructions are, of course, included with the tester.

The Hodges Volatility Tester gives an on-the-spot answer to the question - "could the fuel cause vapor lock?" - and unlike all other standard tests it does not give an answer that needs further interpretation. If the fuel has weathered to a lower Reid Vapor Pressure (RVP) than normal, the equipment automatically accounts for the current vapor pressure, and registers a "safe or unsafe" result dependent only on the current value. This capacity to read current value gives the pilot the option of blending fuels until a safe reading is obtained, or of delaying the flight until a cooler part of the day when a "safe" reading can be obtained.

Please note that the volatility tester does not give octane ratings, nor does it specifically give you RVP. However, a chart is available at your request that can be used to extrapolate RVP to within 1 psi. RVP by itself means nothing. The tester is designed to give a "go-no go" indication which is really the most useful way to evaluate the fuel for vapor lock potential. Furthermore, samples for testing must be fresh, since any sample collected in an open jar or blends tested that are not properly mixed won't give a true result.

The Hodges Volatility Tester sells for \$65.00 (shipping included). Purchase from Peterson Aviation.

## **Supplement Number 4**

**Model: Zodiac XLi**

### **Garmin GNS 430 GPS Navigator With VHF Nav, ILS, and VHF Com**

When a Garmin GNS 430 GPS Navigator with NAV, ILS, and COM is installed in the **Zodiac XLi**, this supplement is applicable and must be inserted in the **Zodiac XLi** Pilot's Operating handbook. This document must be carried in the airplane at all times. Information in this supplement either adds to, supersedes, or deletes information in the basic **Zodiac XLi** Pilot's Operating Handbook.

**SUPPLEMENT NUMBER 2  
LOG OF REVISIONS**

| <b>Revision Date</b> | <b>Revised Pages</b> | <b>Description of Revision</b> |
|----------------------|----------------------|--------------------------------|
| JAN 06               | All pages            | Initial Issue                  |
|                      |                      |                                |
|                      |                      |                                |
|                      |                      |                                |

| <b>Supplement<br/>Number 4</b> | <b>Page</b> | <b>Date</b> |
|--------------------------------|-------------|-------------|
|                                | 1           | JAN 06      |
|                                | 2           | JAN 06      |
|                                | 3           | JAN 06      |
|                                | 4           | JAN 06      |
|                                | 5           | JAN 06      |
|                                | 6           | JAN 06      |
|                                | 7           | JAN 06      |

**SUPPLEMENT #4 GARMIN GNS 430 - IFR  
ZODIAC XL-SLSA WITH 0-200 ENGINE**

---

**(a) GENERAL**

The airplane is equipped with a Garmin GNS 430 GPS Navigator with VHF Nav, ILS, and VHF Com herein referred to as the “Navigator”. The GNS 430 is capable of providing IFR enroute, terminal, and approach navigation with position accuracies better than 15 meters. The system utilizes the Global Positioning System (GPS) satellite network to derive the airplane’s position (latitude, longitude, and altitude) and the altitude digitizer to enhance the altitude calculation.



Power to the Garmin avionics is supplied from the aircraft battery to the Avionics Master Switch Breaker. Power for the Bendix/King KX155 is supplied from the aircraft power bar, through the main aircraft master.

**(b) LIMITATIONS**

Provided the GPS Navigator is receiving adequate usable signals, it has been demonstrated capable of and has been shown to meet the accuracy specifications of:

VFR/IFR, enroute, terminal, and instrument approach (GPS, VOR) operations, that is, enroute, terminal, and instrument approach within the U.S. National Airspace System, North Atlantic Minimum Navigation Performance Specification (MNPS) Airspace using the WGS-84 (or NAD 83) coordinate reference datum in accordance with the criteria of AC 20-138, AC 91-49, and AC 120-33. Navigation data is based upon use of only the global positioning system (GPS) operated by the United States.

1. The Garmin GNS 430 Pilot's Guide and Reference, P/N 190-00140-00, Revision A dated December 1998 (or later appropriate revision) must be immediately available to the flight crew whenever navigation is predicated on the use of the GPS Navigator. The software status stated in the pilot's guide must match that displayed on the equipment.
2. The Navigator must utilize software version 2.XX (where X is a digit, 0-9).
3. GPS/IFR enroute and terminal navigation is prohibited unless the pilot verifies the currency of the database or verifies each selected waypoint for accuracy by reference to current approved data.
4. GPS instrument approaches must be accomplished in accordance with approved instrument approach procedures that are retrieved from the Navigator's NavData database. The database must incorporate the current update cycle.
  - a. Instrument approaches must be conducted in the approach mode and RAIM must be available at the Final Approach Fix.
  - b. Accomplishment of ILS, LOC, LOC-BC, LDA, SDF, and MLS approaches are not authorized in GPS mode.
  - c. The following limitation applies when required by national regulations: When an alternate airport is required by the applicable operating rules, it must be served by an approach based on other than GPS navigation, the aircraft must have operational equipment capable of using that navigation aid, and the required navigation aid must be operational.
5. The aircraft must have other approved navigation equipment installed and operating appropriate to the route of flight.



**(c) EMERGENCY PROCEDURES**

1. If GPS Navigator information is not available or is invalid, utilize remaining operational navigation equipment as required.
2. If “RAIM NOT AVAILABLE...” or “RAIM POSITION WARNING” message is displayed, continue to navigate using the GPS equipment or revert to an alternate means of navigation appropriate to the route and phase of flight. When continuing to use GPS navigation, position must be verified every 15 minutes using another IFR approved navigation system.

**(d) Normal Procedures**

Normal operating procedures are outlined in the GARMIN GNS 430 Pilot’s Guide and Reference, P/N 190-00140-00, Revision A dated December 1998 (or later appropriate revision).

**(e) Activate GPS**

1. Avionics Master Switch Breaker - on panel ----- ON
2. Navigator Com/ Power Switch - on Garmin GNS-430 unit ----- Rotate ‘ON’  
The Navigator will display a welcome page while the self-test is in progress. When the self test is successfully completed, the Navigator asks for NavData database confirmation, acquires position, and then displays the acquired position on the Navigator’s display and on the ARNAV display.

**Note:** The Navigator is not coupled to an air and fuel data computer. Manual fuel-on-board and fuel flow entries must be made in order to use the fuel planning function of the AUX pages.

The GPS Navigator utilizes altitude information from the altitude encoder’s altitude digitizer to enhance altitude information.

**(f) GNS 430 Integration**

The GNS 430 Navigator is integrated in the CH2000 Avionics installation:  
Single GARMIN GNS 430 (GPS) interfaced with the CDI.

In this configuration, pressing the alternate-action CDI push-button on the GARMIN GNS 430 alternately selects GPS or NAV for display on the CDI each time the button is pressed. The CDI source is indicated by illumination of the “GPS” or “VLOC” annunciation in the lower left corner of the GNS 430 display.

Note: The CDI displays course deviation from a VOR, Localizer (LOC) or Glideslope (G/S) when VLOC is selected for display and displays GPS track deviation when GPS is the selected navigation source.

**(g) Deactivate GPS**

1. Navigator Com/ Power Switch----- Rotate CCW 'OFF'

**(h) PERFORMANCE**

No change from basic Handbook.

**(i) WEIGHT & BALANCE**

No change from basic Handbook

**(j) SYSTEM DESCRIPTION**

**Note:** This supplement provides a general description of the Garmin GNS 430, and its operation. For a detailed description of the GNS 430 and **full operation instructions refer to the Garmin GNS 430 Pilot's Guide and Reference, P/N 190-00140-00, Revision A dated December 1998 (or later appropriate revision).**

**(k) GNS 430 Integrated GPS/Nav/Com System**

This airplane is equipped with a GNS 430 integrated GPS navigator, NAV receiver, and COM transceiver. The GPS navigator consists of a GPS receiver, a navigation computer, and a Jeppesen NavData database all contained in the GNS 430 control unit mounted in the center console. A VHF NAV receiver and tuner for receiving VHF Omnidirectional Range (VOR), Localizer (LOC), and Glideslope (G/S) is also integrated into the control unit. The NAV receiver is designated 'NAV 1'. Additionally, a VHF communications receiver designated "COM 1, is also integrated into the unit. All tuning and display controls for the GPS, NAV, and COM are located in the GNS 430 control/display in the center console. The following paragraphs describe the GPS, NAV, and COM functions of this unit. For a complete description, as well as full operating instructions, refer to the Garmin GNS 430 Pilot's Guide and Reference.

**(l) GPS Navigator**

The Garmin GPS 430 is capable of providing IFR enroute, terminal, and approach navigation with position accuracies better than 15 meters. The system utilizes the Global Positioning System (GPS) satellite network to derive the airplane's position (latitude, longitude, and altitude) and the altitude digitizer to enhance the altitude calculation. The GPS antenna is located behind the cabin roof along the airplane centerline. All GPS navigator controls and functions are accessible through the GNS 430 front control panel located in the center console. The panel includes function keys, power switches, MSG and Nav status annunciators, color LCD display, concentric selector knobs, and a Jeppesen NavData card slot. The GNS 430 navigator is powered by 14 VDC through the 5-amp GPS circuit breaker.

**SUPPLEMENT #4 GARMIN GNS 430 - IFR  
ZODIAC XL-SLSA WITH 0-200 ENGINE**

---

The Jeppesen Navigation Database provides access to data on Airports, Approaches, Standard Instrument Departures (SIDs), Standard Terminal Arrivals (STARs), VORs, NDBs, Intersections, Minimum Safe Altitudes, Controlled Airspace Advisories and Frequencies. North American and International databases are available. Database information is provided on a card that can be inserted into the card slot on the GPS unit. Subscription information is provided in a subscription package provided with each system.

**(m) Navigation (Nav) Receiver**

The Garmin GNS 430 provides an integrated Navigation (NAV) receiver with VHF Omirange/Localizer (VOR/LOC) and Glideslope (G/S) capability. The VOR/LOC receiver receives on a frequency range from 108,000 MHz to 117,950 MHz with 50 KHz spacing. Glideslope is received from 329.150 to 335.00 in 150 KHz steps. The Nav receiver controls are integrated into the Garmin GNS 430 control mounted in the center console. The receiver control provides active and standby frequency indication, frequency memory storage, and knob-operated frequency selection. IDENT audio output for VOR and LOC is provided to the audio system. The Nav antenna is mounted at the vertical tail. Fourteen VDC for navigation receiver operation is controlled through the Avionics Master Switch on the bolster switch panel and supplied through the 5-amp GPS circuit breaker on the Avionics Essential Bus. The airplane is equipped with a Garmin GNS 430 integrated GPS Navigator, Navigation (NAV) receiver with VHF Omirange/Localizer (VOR/LOC) and Glideslope receiver.

**(n) Communication (COM) Transceiver**

The GNS 430 includes a digitally-tuned integrated VHF communications (COM) transceiver. The transceiver and integrated controls are mounted in the Garmin GNS 430 unit. The transceiver receives all narrow and wide-band VHF communication transmissions transmitted with a frequency range of 118,000 MHz to 136,975 MHz in 25.0 KHz steps (720 channels). For European operations, the COM can be operator configured for 8.33 KHz channel spacing (2280 channels). The tuning controls are collocated with the NAV at the left side of the GNS 430 front panel. Frequency tuning is accomplished by rotating the large and small concentric knobs to select a standby frequency and then transferring the frequency to the active window. The COM frequency display window is at the upper left corner of the GNS 430 display. Auto-tuning can be accomplished by entering a frequency from a menu. The COM antenna is located above the cabin on the airplane centerline.