

INSTRUCTION AND MAINTENANCE MANUAL
FOR
JABIRU 3300 AIRCRAFT ENGINE

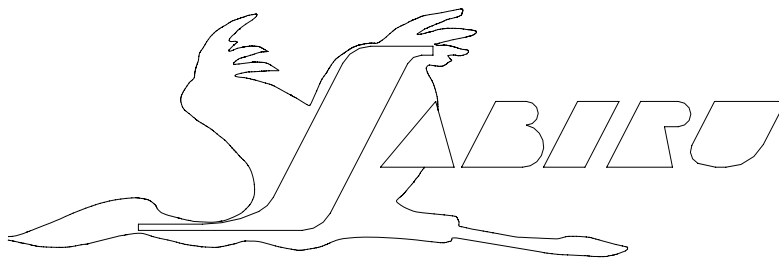

This Manual has been prepared as a guide to correctly operate, maintain and service the Jabiru 3300 engine.

Should you have any questions or doubts about the contents of this manual, please contact Jabiru Aircraft Pty Ltd.

Table of Contents

Paragraph	Description	Page
	<i>Table of Contents</i>	2
	<i>List of Amendments</i>	4
1.0	<i>Description</i>	5
1.1	Denomination of Cylinders	8
2.0	<i>Technical Data</i>	9
2.1	Dimensions & Weights	9
2.2	Normal Equipment	9
2.3	Performance Data	9
2.4	Fuel Consumption	9
2.5	Fuel & Lubricant	9
2.6	Cooling System	10
2.7	Operating Speeds & Limits	10
3.0	<i>Performance Graphs</i>	11
4.0	<i>Operating Instructions</i>	12
4.1	Pre-Start Checks	12
4.2	Starting Procedure	12
4.3	Warm-Up Period, Ground Test	12
4.4	Take-Off	12
4.5	Engine Stop	13
4.6	Engine Stop & Start During Flight	13
4.7	(Addition) Early Operation of Engine	13
5.0	<i>Checks on Engine & Installation</i>	14
5.1	Daily Checks	14
5.2	Periodic Checks	14
5.3	Check After Initial 25 Hours	15
5.4	50 Hours Check	16
5.5	100 Hours Check	16
5.6	TBO	16
5.7	Engine Preservation	17
5.8	Operation in Winter	20
6.0	<i>Maintenance</i>	21
6.1	Lubrication System	21
6.2	Air Intake Filter	21
6.3	Carburettor Adjustment	21
6.4	Compression Check	21
6.5	Spark Plugs	22
6.6	Exhaust System	22
6.7	Bolts & Nuts	22
6.8	Tappet Adjustment	23
6.9	Tachometer and Sender	23

6.10	Additional Checks	23
7.0	<i>Service & Repair</i>	24
7.1	Engine Overhaul and TBO	24
7.2	Engine Removal Procedure	25
7.3	Disassembly	26
7.4	3300 Engine Overhaul	29
	1 Subassembly A - Crankshaft Prop Mount and Con rods	30
	2 Subassembly B - Crankcase and Camshaft	33
	3 Subassembly C - Pistons, Cylinders and Cylinder Heads	35
	4 Subassembly D - Sump and Oil Pump	42
	5 Subassembly E - Flywheel and Ignition Coils & Alternator & Alternator Operation	44
	6 Subassembly F - Gear Case	49
	7 Subassembly G - Fuel Pump & Carburettor & Carburettor Operation	50
	8 Subassembly H - Final assembly of subassemblies	56
	9 Run in	65
7.5	Engine Installation and First 25 hours	66
7.6	Prop Strike Inspection	67
7.7	Build Sheets and Run in programme	68
8.0	<i>Table of Lubricants</i>	86
9.0	<i>Torque Specifications</i>	87
9.1	Prescribed Sealants and Primers	88
9.2	New Tolerances	89
9.3	Maximum Allowable Clearances (Wear Limits)	90
9.4	Electrical System Specifications	91
10.0	<i>Trouble Shooting</i>	92
10.1	Engine Won't Start	92
10.2	Engine Idles Unsteadily After Warm-Up Period: Smoky Exhaust Emission	92
10.3	Engine Runs Erratically or Misfires Occasionally	92
10.4	Engine Runs Too Hot, Oil Temperature above 110°C (230°F)	93
10.5	Unsatisfactory Power Output	93
10.6	Low Oil Pressure	93
10.7	Engine Keeps Running with Ignition OFF	93
10.8	Excessive Oil Consumption	94
10.9	Knocking Under Load	94
10.10	Engine Hard to Start at Low Temperature	94
11.0	Engine Warranty Form	95
		96

List of Amendments

Page	Amendment	Date	Issue
------	-----------	------	-------

1.0 DESCRIPTION OF DESIGN

- ✓ 4 Stroke
- ✓ 6 Cylinder
- ✓ Horizontally Opposed
- ✓ One Central Camshaft
- ✓ Pushrods
- ✓ OHV
- ✓ Ram Air Cooled
- ✓ Wet Sump Lubrication
- ✓ Direct Propeller Drive
- ✓ Dual Transistorised Magneto Ignition
- ✓ Integrated AC Generator
- ✓ Electric Starter
- ✓ Mechanical Fuel Pump
- ✓ Pressure Compensating Carburettor (Bing Type 94/40)

It is said that "aircraft are designed around available engines".

Jabiru believe that the Jabiru range of very light engines will now offer new opportunities for light aircraft designers, to develop a new generation of light aircraft.

Jabiru engines are designed to be manufactured in small batch quantities using the very latest Computer Numerically Controlled (CNC) machine tools. The vast majority of the components are manufactured in Southern Queensland in a network of high technology small companies. The crankcase halves, cylinder, crankshaft, starter motor housings, gearbox cover (the gearbox powers the distributor rotors) and coil mounts together with many smaller components are machined using the latest CNC machine tools. The sump (oil pan) is the only casting. The cylinders are machined from solid bar 4140 chrome molybdenum alloy steel, with the pistons running directly in the steel bores. The crankshaft is also machined from solid bar 4140 chrome molybdenum alloy steel, the journals of which are precision ground prior to being Magnaflux inspected. The camshaft is manufactured of 4140 steel and hardened using a nitriding process.

The propeller is direct crankshaft driven and does not use a reduction gearbox. This facilitates its light-weight design and keeps maintenance costs to a minimum. The crankshaft features a removable propeller flange which enables the easy replacement of the front crankshaft seal and provides for a propeller shaft extension to be fitted, should this be required for particular applications. Cylinder heads are machined from solid aluminium billet which is purchased directly from one of Australia's largest aluminium companies, as is all alloy used in the engine, thereby providing a substantive quality trail to material source. Conrods are machined from 4130 alloy steel, the 45mm big end bearings are of the automotive slipper type.

Under a direct supply arrangement with Honda, various components of the engines are sourced. These items include camshaft followers, and the bendix gear in the starter motor.

The ignition coils are also sourced from Honda, but are modified by Jabiru for their own particular application.

An integral alternator using rare earth magnets, provides alternating current for battery charging and electrical accessory drive. The alternator is attached to the flywheel and is driven directly by the crankshaft. The ignition system is a transistorised electronic system; two fixed coils mounted adjacent to the flywheel are energised by rare earth magnets attached to the flywheel. The passing of the coils by the magnets creates the high voltage current which is then transported by high tension leads to the centre post of two automotive type distributors (which are simply rotors and caps) before distribution to automotive spark plugs, two in the top of each cylinder head. The ignition system is fixed timing and, therefore, removes the need for timing adjustment. It is suppressed to prevent radio interference. The ignition system is fully redundant, self-generating and does not depend on battery power.

The crankshaft is designed with a double bearing at the propeller flange end and a main bearing between each big end; it therefore does not have flying webs. 48mm main bearings are also of the automotive slipper type. Thrust bearings are located for and aft of the front double bearing allowing either tractor or pusher installation.

Pistons are General Motors aftermarket made in Australia and are re-machined to include a piston pin circlip groove. They are fitted with 3 rings, the top rings being cast iron to complement the chrome molybdenum cylinder bores. Valves are 7mm (stem dia) which are purpose manufactured for the Jabiru engine in England.

The valve gear includes pushrods from the camshaft from the camshaft followers to valve rockers which are CNC machined from steel plate, induction hardened and polished on contact surfaces and mounted on a shaft through a teflon bronze-steel bush. Valve guides are manufactured from aluminium/bronze, as is found in larger aero engines and high performance racing engines. Replaceable valve seats are of nickel steel and are shrunk into the aluminium cylinder heads. The valve gear is lubricated from the oil gallery.

An internal gear pump, direct mounted on the camshaft and incorporating a small automotive spin-on filter, provides engine lubrication. An oil cooler adapter is provided. Most installations require an oil cooler to meet oil temperature limits.

The standard engines are supplied with two RAMAIR cooling ducts, which have been developed by Jabiru to facilitate the cooling of the engine and direct air from the propeller to the critical areas of the engine, particularly the cylinder heads and barrels. The fitment of these RAMAIR cooling ducts is a great bonus for the home builder or engine installer, as they obviate the need to design and manufacture baffles and the establishment of a plenum chamber, which is the traditional method of cooling air-cooled aircraft engines. The fact that these baffles and plenum chamber are not required also ensures a "cleaner" engine installation, which in turn facilitates maintenance and inspection of the engine and engine component. So the hard work of engine installation has largely been done for you by the Jabiru design team. RAMAIR ducts are available for tractor or pusher configurations. Special ducts are available for certain installations.

The engine is fitted with a 1 kw starter motor, which is also manufactured by Jabiru and provides very effective starting. The engine has very low vibration levels, however it is also supported by four large rubber shock mounts attached to the engine mounts at the rear of the engine. An optional bed mount is available.

The fuel induction system comprises a BING pressure compensating carburettor. Following carburation, the fuel/air mixture is transported to a small plenum chamber in the sump casting, in which the mixture is warmed prior to entering short induction tubes attached to the cylinder heads.

An effective stainless steel exhaust and muffler system is fitted as standard equipment, ensuring very quiet operations, which in the Jabiru aircraft have been measured at 62dB at 1000' full power flyover (for 2200 engine).

For those owners wanting to fit vacuum instruments to their aircraft the Jabiru engine design includes a vacuum pump drive, direct mounted through a coupling on the rear of the crankshaft.

The Jabiru engine is manufactured within an Australian Civil Aviation Safety Authority (CASA) approved Quality Assurance System to exacting standards.

Jabiru recommend a TBO of 1000 hours for both of their engines. A Guaranteed Fixed Price Overhaul Plan* is offered with both engines. Contact your regional distributor or Jabiru Aircraft for details.

Jabiru engine Warranty* is 200 hours or 12 months (whichever comes first) from date of sale or from date of independently verified first flight.

**Conditions Apply*

1.1 Denomination of Cylinders

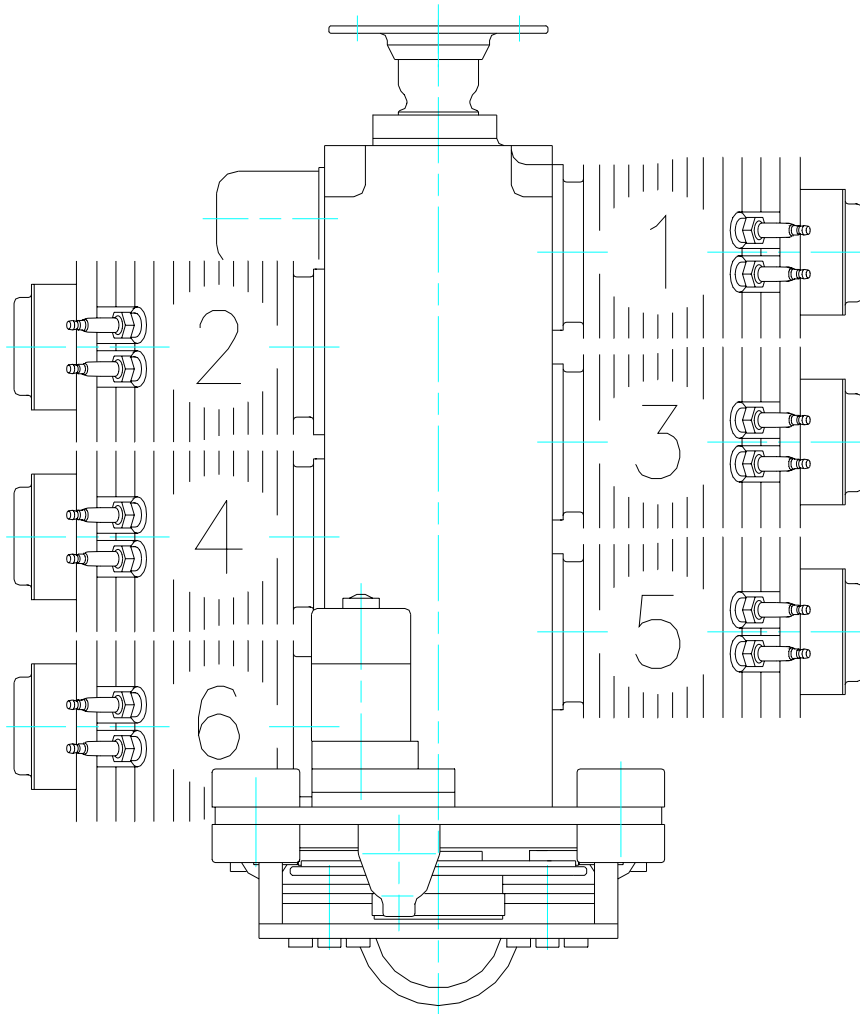

Drawing 9476083

2.0 TECHNICAL DATA

2.1 Dimensions and Weights

Bore:	97.5 mm
Stroke:	74 mm
Displacement:	3314 cc
Compression Ratio:	7.8:1
Direction of Rotation on Prop Shaft:	Clockwise Pilot's view, tractor applications.
Engine Curb Weight:	81 kg (178 lb) complete with Engine Oil, Exhaust and Starter Motor.

2.2 Normal Equipment

Ignition Unit:	Jabiru dual ignition - breakerless transistorised. Battery Independent
Ignition Timing:	25 degrees BTDC
Firing Order:	1 - 4 - 5 - 2 - 3 - 6
Spark Plugs:	NGK D9EA
Electrode Gap:	0.55 - 0.6mm (0.022" - 0.024")
Generator:	Jabiru, permanently excited three phase or single phase AC generator with rectifier/regulator
DC Output:	15 amps (continuous)
Carburettor:	BING constant depression type 94/40
Air Intake Filter:	1 x folded paper cartridge
Fuel Filtration:	0.1 mm (100 Micron) maximum particle size.
Fuel Pump:	Camshaft driven diaphragm type
Starting System:	Electric 12 V / 1.0 kW

2.3 Performance Data

Maximum	90 kW (120 hp) @ 3300 RPM ISO STD Conditions
---------	--

2.4 Fuel Consumption

Fuel Consumption @ Takeoff/Max Continuous Rating	28.5 litres/hr
--	----------------

2.5 Fuel and Lubricant

Fuel: AVGAS 100 LL & AVGAS 100/130

Leaded and Unleaded Automotive Gasoline above 95 Octane Ron

Run in Period

Oil	80	100	120
Outside Air Temp	-17°C to 25°C (1° to 77°F)	15°C to 35°C (59° to 95°F)	Above 35°C (Above 95°F)

Normal Operations

Oil	W80	W100	W120
Outside Air Temp	-17°C to 25°C (1° to 77°F)	15°C to 35°C (59° to 95°F)	Above 35°C (Above 95°F)

2.6 Cooling System

Free air cooled. Ensure that baffles are correctly fitted & located.

The required pressure drop across the cylinders at 1.3 Vs in take off configuration is 4.3 cm (1.7") water gauge, minimum.

2.7 Operating Speeds and Limits

Maximum continuous speed		2750 RPM
Maximum		3300 RPM ISO STD Conditions
Idle Speed:		650 RPM
Oil Pressure:	Normal Operations	Min 220 kPa (31 psi)
		Max 525 kPa (76 psi)
	Idle	Min 80 kPa (11 psi)
	Starting & Warm up	Max 525 kPa (76 psi)
Oil Temperature:	Min.	15 °C (59°F)
	Max.	118 °C (244°F)
Continuous Temperature:		80 - 100 °C (176° - 212°F)
Max. Cylinder Head Temperature:		175 °C (348°F)
		(reading on the sensor spot of the hottest cylinder)
Continuous		150°C (302° F) Max.

3.0 PERFORMANCE GRAPHS

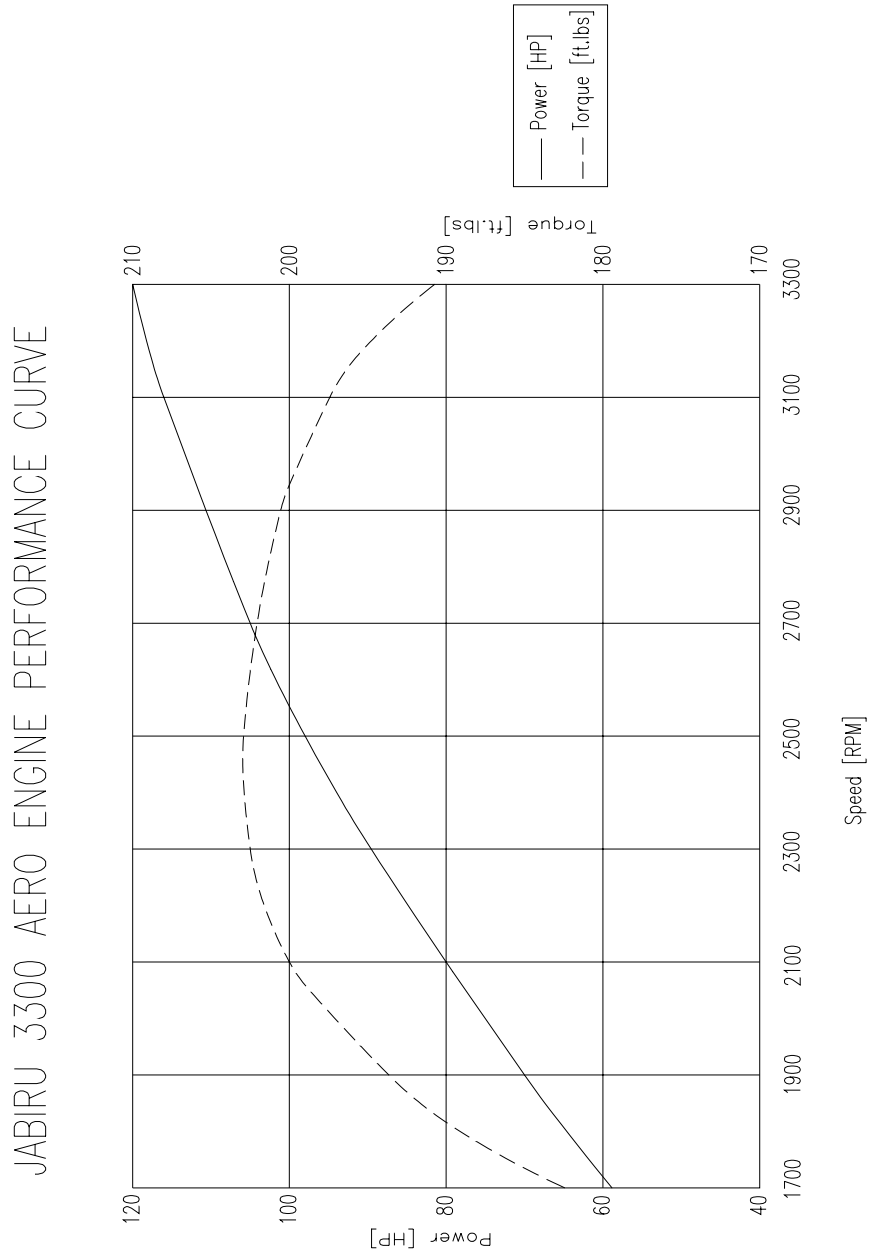

Drawing 9484093/1 3300 ENGINE POWER CURVE

4.0 OPERATING INSTRUCTIONS

To ensure that the engine operates reliably, carefully observe all of the operating & maintenance instructions.

4.1 Pre-Start Checks

Daily Checks (See Paragraph 5.1)

Move throttle position to FULL & check for ease of movement over the entire range.

4.2 Starting Procedure

Fuel Tap	OPEN
Choke	ON (in cold conditions)
Fuel Pump	ON for 10 seconds then off
Throttle	CLOSED to Stop
Master	ON
Ignition	BOTH ON
Starter	PRESS

Attention: Activate Starter for a max. 20 seconds, followed by a cooling period of 1 minute.

When engine runs, adjust throttle to achieve smooth running at approximately 1200 RPM. Deactivate Choke. Check Oil Pressure has risen within 5 seconds - if not, shut down.

4.3 Warming Up Period, Ground Test

Start the warming up period with the engine running at 1000 RPM. Continue at 1400 RPM depending on ambient temperature, until oil temperature reaches 15°C (59°F). Check the two ignition circuits at 1600 RPM. Note: - RPM with only one ignition should not drop by more than 100 RPM.

DO NOT apply full power until CHT reaches 100 °C (212°F)

DO NOT allow cylinder heads to rise above 150°C during ground running.

4.4 Take-Off

Climb with the engine at maximum continuous power. Observe Oil & Cylinder Head Temperatures & Oil Pressure Limits must not be exceeded !

4.5 Engine Stop

In normal conditions, cooling down the engine during descent & taxiing will permit the engine to be stopped by switching OFF the ignitions.

4.6 Engine Stop and Start During Flight

Reduce power to 1000 RPM to cool engine for 30 seconds, then to idle. Switch ignitions OFF. Starting procedure is the same as ground starting, without choke for a warm engine & with choke for a cold engine. Note: Engine cools quickly with propeller stopped in flight. Choke will therefore normally be needed to restart.

4.7 Addition} Early Operation of Engine

JABIRU ENGINE NOTES

NEW ENGINE NOTES:

This engine has been ground run to a specific run in program and is ready for flight. It has been *INHIBITED* however if you intend to store for any length of time please refer to 5.7 Section 3 of *INSTRUCTION AND MAINTENANCE MANUAL*. Removing spark plugs and turning over will help periodically. Before initial start, oil engine 3.4 litres (with cooler) remove one plug per head activate starter to remove excess inhibitor. Once oil pressure is obtained replace plugs and continue start-up sequence. The following are tips to ensure a long life.

1. OIL

Use a non-compounded *AVIATION* oil:-

- ***Aero Shell 100***
- ***Mobil Red Band***
- ***BP Aviation Oil 100***

Use for 20-25 hours.

Drain and replace with a compounded oil:-

- ***Aero Shell W100***
- ***Aero Shell 15W50 (for cooler climates)***
- ***Mobil Aero 100 (SAE 50)***
- ***BP Aero Oil D100/BP Multigrade Aero Oil D SAE 20 W 50***
- ***Aero Shell W 100 Plus***

The normal running oils are detergent and ashless dispersant types. See *MAINTENANCE SECTION 5.3*

2. **Add** **3.2 Litres (without oil cooler)**
 3.4 Litres (with an oil cooler)

3. **Avoid prolonged ground running at elevated RPM. Engine can be over heated, remember air ducts are designed for in flight cooling. NOTE: remove ALL plastic bungs on engine. EXHAUST (4) CARBY (2) OIL VENT (1) FUEL PUMP (1)**

4. **DO TAKE OFF AT FULL POWER.**
For the first few take offs climb at a higher airspeed. Reduce power at cross wind leg and shallow climb (lower nose).

5. **VARY your RPM when flying.**

6. **Avoid high nose altitude continual climbs. The higher the climb out speed the better for engine cooling. No low speed high nose altitude climb outs.**

7.

Ring bed in is accomplished better at 75% power and above. Avoid heat build up. Monitor CHT and oil temps. Vary RPM. Initial temps will be elevated due to friction of a new engine.

8. **CIRCUIT WORK is possibly a good sequence for initial run in work. Abbreviate circuits initially, step climb, climb shallow. No glide approaches. Gradually reduce power. Avoid sudden heating up and sudden cooling down.**

9. **RETORQUE heads as suggested on warning sheet. 24 ft lb and .010" valve clearance all done cold. Subsequent torquing of around 22 to 24 seems to help in settling down head bolts and heads.**

10. **Don't *BABY YOUR ENGINE* but monitor carefully CHT and oil temp initially especially during the first few hours of operation.**
Remember engines need to be flown. They are designed for this purpose. Do not use full power before CHT reaches 100°C.

The purpose of breaking in an engine correctly is to ensure a long reliable life. All moving parts need freeing up especially piston rings to cylinder walls. This is best accomplished when the greatest B.M.E.P. (Break Mean Effective Pressure) occurs. That is at 75% power and above. Careful monitoring by the pilot is needed during this initial period to ensure long life of the engine and its components.

- 11. Do not use any type of automotive oil. These oils have not been blended for the purpose of air cooled aero engine operation and will be detrimental to its operation.**
- 12. Use *AVGAS 100 LL* or the highest Octane Mogas above 95 containing lead. Engines not shimmed on the cylinder base should only be run on *AVGAS*.**
- 13. When you change oil from the “run in” type to the “normal” oil at or around 25 hrs replace oil filter. You may want to cut the filter open for inspection. It is usual in Jabiru engines to find a small amount of aluminium but definitely no metal. If bearing metal is present contact the Jabiru Service Department.**
- 14. With ignition and master OFF and throttle closed turn the prop by hand and observe engine for odd noises or heavy movements.
Check for regular compressions, if irregular firstly check tappet adjustment. Operation with incorrectly adjusted tappets with result in damage to valves, valve seats, guides and overhead gear.**

HEAD TORQUING/VALVE SETTING

Your tension wrench should be accurate. It should have had some method of calibration. They can vary to manufacturers claims.

***24 ft lb on head bolts
.010" on valve clearance cold***

Engines use a 9/16 thin walled or tubed socket and a blade screwdriver.

Easiest method of setting valves requires you to pull the prop until exhaust valve on No.1 cylinder is fully depressed. Note the O'clock position. Rotate prop 360° and adjust valve. (This puts the cam and lifter at 180° to the peak lift). Repeat for each valve. Heads and valves should be done at least twice at 5 hrs and 10 hrs on a new engine. You may also adjust each cylinders valves on the firing stroke. (Firing order 145236 at TDC)

Remember to go over exhaust cap screws. They are fitted with shakeproof washers to prevent loosening.

AIR DUCTS

Periodic research and development does cause at time changes to occur. Ones supplied need to be fitted. See instructions manual.

FILTERS

Inspections down the track are a must for fuel and air filters. Conditions will dictate when changed. The air box has a rubber flap to give partial inspection of filter.

SPARK PLUGS

NGK D9EA are recommended.

Plug gap of around .022" to .024". Remember plugs are installed at around 8 ft lb or given 1/2 turn after contact with head. 18mm Plug spanner used.

COMPRESSION TESTING

Condition of compression can be done by a compression gauge. Wide open throttle, engine warm. Turn over on starter. Below 90 PSI would indicate removal of head and possibly cylinder.

PRESSURE DIFFERENTIAL TEST (Leak down)

This is a much better test for condition of rings, bore, head sealing and valve. Engine in warm to hot condition. This is the normal test used in aviation requiring specific equipment for the job. Pressure input of 80 PSI; a second gauge reads the differential when supplying 80 PSI. This is done with piston on TDC on the firing stroke. Prop needs to be restrained. The differential cut off is 80/60. Problems can be better identified eg.

- **BLOW BY (CRANKCASE VENT) - RINGS, BORE SEAL**
- **LEAKING FROM CARBY - INTAKE VALVE SEAL**
- **LEAKING FROM EXHAUST - EXHAUST VALVE SEAL**
- **HEAD LEAK - HEAD GASKET OR HEAD TO CYLINDER SEAL**

Correction work can then be carried out.

COIL GAP

Best done with a piece of plastic or thin card of a thickness .010". Cut into a strip approximately 15mm wide.

Place between magnets on flywheel and coil.

STARTING

A warm idle of around 650 RPM will automatically create the right starting environment. Idle set screw may have to be adjusted. Carby has been factory set. Normal start requires throttle closed, that is the idle criteria has just cracked the butterfly in the throat body and also apply choke. The engine is difficult to start if throttle is cracked open somewhat.

As the engine is cranked the choke should be pushed off. Engine should fire. The choke is only used for a cold start. Prolonged cranking with choke will only "flood" the intake system making starting difficult. Should this occur, leave or clear the system on full throttle momentarily (mags off).

Cranking speed if too slow (poor battery or starter fault) will prevent magneto operation.

Jump starting (with care) will point towards poor battery condition or faulty alternator charging.

Further testing would then be required in these areas to identify the problem.

POSSIBLE PROBLEMS

See "Trouble Shooting" Section of 10.0 of Maintenance Manual.

It is unusual for a problem to occur however a few of "common" type are listed.

1. LOW OIL PRESSURE

A sudden drop of pressure usually is caused by a small piece of foreign matter being lodged under the relief valve. Simply remove oil filter and cooler adaptor (if fitted). Remove matter by depressing plunger or removing relief mechanism. Replace and check operation by ground run. If low pressure persists the problem will need further investigation.

We strongly recommend the fitting of an approved oil cooler to Jabiru engines.

2. FLICKING OF OIL PRESSURE GAUGE

It is not uncommon for the Jabiru engine to display flicking of the needle pointer for brief periods but still within normal operating regions. If it continues, check continuity of sender lead and or possible sender change. (We are assuming oil level is OK).

3. CHT

Possible not reading can be cause by a break in the sender wires or incorrect polarity. High readings can result with poorly centred sender under the spark plug. Normal cruise CHT should not

exceed 150°C and climb must not exceed 175°C. Air ducts supplied at present give results below these figures.

4. RPM

Tacho's may need adjustment when a new engine is fitted. Inducted magnet sender units require coil gap to flywheel gear teeth of .014" or .35mm. Tacho's using this sender require a "pot" adjustment, access through outside of case.

Tacho's using the magneto as sender requires a sequence of operation for correction. This information can be faxed if required.

5. MAGNETO CHECKS

Possible causes of abnormal drop could be loose leads, faulty leads, rotor buttons, coil gaps, spark plugs.

6. ROUGH CYLINDER RUNNING

Check plugs/valve clearance and the induction system for looseness.

7. CARBY BREATHER

Later model carbies have a brass fitting for venting. This is easily connected via a clear plastic hose to a fitting screwed into the carby heat box. On earlier carbies we supplied a kit for this purpose as no internal carby fitting was installed.

8. LIMITATIONS

Warranty notes follow.

Jabiru recommend TBO of 1000 hrs. A guaranteed fixed price overhaul exists through the Jabiru factory.

Warranty is 200 hours or 12 months which ever comes first.

CAREFULLY READ MANUALS SUPPLIED

5.0 CHECKS ON ENGINE & INSTALLATION

5.1 Daily Checks

- * Ensure free movement of throttle & choke cables.
- * Check Oil Level, replenish if necessary. Oil level should be between the MAX & MIN marks - but must never be below the MIN mark. Before long periods of operation, ensure that the level is at least at the mid position. Difference in the oil quantity between MAX & MIN mark is 0.75 litres (0.792 US Quarts).
- * Check security of spark plugs, leads & electrical connections.
- * Check lubrication & fuel system for leaks.
- * Check exhaust system for security & leaks.
- * With Ignition & Master OFF and throttle closed, turn propeller by hand & observe engine for odd noises or heavy movements. Check for regular compression. If irregular, firstly check tappet adjustment (see para 6.8).

IMPORTANT

Prior to pulling through the propeller by hand, both ignition circuits & the Master must be switched OFF, the brakes applied, throttle closed & the cockpit attended by a trained person.

WARNING

A hot engine may fire with the ignition/s switched OFF.

CAUTION

Continued operation with incorrectly adjusted tappets will result in damage to valves, valve seats, valve guides & overhead gear.

- * Prior to takeoff - follow the Starting & Warm Up procedure, observe the engine behaviour & throttle response.
- * Check temperatures & pressures. Conduct a short ground test at full power (10 seconds Max.) (consult aircraft Flight Manual).

5.2 Periodic Checks

After the initial 25 hours, check in accordance with para. 5.3.

After 50 hours of operation, check in accordance with para. 5.4 & thereafter after each 50 hours of operation.

After 100 hours of operation, check in accordance with para. 5.5 and thereafter after each 100 hours of operation.

At TBO, overhaul in accordance with para. 5.6.

5.3 Check After Initial 25 Hours

Details of specific operations are shown in Chapter 6 "Maintenance".

- * Remove engine cowlings, check engine mounts.
- * Thoroughly check engine for missing or loose bolts, nuts, pins, etc., & for abrasions.
- * Check induction and exhaust flange for loose bolts.
- * Check safety wires, cooling air ducts & baffles, ignition wiring & hose connections.
- * Oil Change 3.5 litres
- * Change oil filter. (First 25 hours only)
- * Inspect old filter.
- * Retorque cylinder head bolts (24 ft lbs) in diagonal pattern
- * Check tappet clearance and adjust as necessary (refer Para 6.8).
(0.010" cold inlet and exhaust)
- * Check exhaust system.
- * Check fuel system for leaks & abrasion.
- * Check wiring for damage & for tightness.
- * Engine test run.
 - Observe starting, warm up & acceleration behaviour to maximum RPM (10 seconds max)
 - Check temperatures & pressures.
 - Engine stop.

5.4 50 Hours Check

Details of specific operations are shown in Chapter 6 "Maintenance".

* Conduct the items shown under 25 Hour Check at para. 5.3.

5.5 100 Hours Check

Details of specific operations are shown in Chapter 6 "Maintenance".

* Conduct the items shown under 25 Hour Check at para. 5.3.

* Renew spark plugs, if necessary.

5.6 TBO

Details of specific operations are shown in Chapter 6 "Maintenance".

* Engine Overhaul, in accordance with Service Bulletins

* Conduct the items shown under 25 Hour Check at para. 5.3.

* Check clearance on throttle valve shaft. If radial clearance exceeds 0.5mm (0.020"), repair carburettor.

The overhaul work must be carried out to Jabiru specifications at an approved aeronautical service facility or by an approved Jabiru Service Centre.

If necessary, changes to the TBO Limit due to operational experience, will be announced by Jabiru in a Service Bulletin.

5.7 Engine Preservation

The following procedures assume that the engine is installed in a Jabiru LSA airframe. For other aircraft types, refer to the manufacturer's service manual. If the engine is not fitted to an airframe, ignore those items referring to the airframe.

5.7.1 Flyable Storage

Flyable storage is defined as a maximum of 30 days non-operational storage.

Ensure that the engine has been stopped by turning off the fuel valve, thereby not leaving any fuel in the carburettor bowl.

Every 7th day the propeller should be rotated through 5 revolutions, without running the engine. Leave the propeller in the horizontal position to ensure even distribution of liquids in the wood. If left in the vertical position, liquids will drain to the lower tip resulting in an unbalanced propeller.

CAUTION

Ensure that the Master and Ignition Switches are OFF!

5.7.2 Returning Engine to Service

After flyable storage, returning the engine to service is accomplished by performing a thorough pre-flight inspection. Ensure all protective covers are removed.

5.7.3 Temporary or Indefinite Storage

Temporary storage is defined as aircraft in non-operational status for a maximum of 90 days.

Treat as for flyable storage (see Paragraph 5.7.1), plus:

- For temporary storage, fill fuel tank with correct grade of fuel (to prevent moisture accumulation).
- For indefinite storage, drain fuel tank, ensure carburettor bowl is empty by running engine with fuel valve off until it stops or by draining bowl.

Then:

1. Disconnect spark plug leads and remove spark plugs from each cylinder.
2. Using a spray atomiser, spray the oil through the spark plug hole with the piston down, then rotate until both valve are open and respray to coat the induction and exhaust system. When all cylinders are treated leave prop horizontal and retreat each cylinder.

NOTE: Use Shell Aero fluid 2UN (MIL-C-6529C Type 1) Corrosion Preventive Concentrate or similar engine preservative.

CAUTION

Ensure that the Master and Ignition Switches are OFF!

3. Install spark plugs and connect leads.
4. Seal exhaust pipes. Attach a red streamer to each seal. DO NOT seal fuel tank breather.
5. Attach a warning placard to the propeller stating that vents and breathers have been sealed and prop should not be turned.
The engine must not be started with the seals in place.

5.7.4 Inspection During Storage

1. Inspect the interior of at least one cylinder through the spark plug hole for corrosion at least once a month.
2. If, at the end of the 90 day period, the aircraft is to be continued in non-operational storage -- repeat Steps 1-4 above (most will only need to be checked).

5.7.5 Returning Engine to Service

After temporary storage, the procedures for returning the aircraft to service are as follows:

1. Check battery and install.
2. Check carburettor air filter and service if necessary.
3. Remove warning placard from propeller.
4. Remove materials used to cover openings.
5. Remove, clean and gap spark plugs.
6. While spark plugs are removed, rotate propeller several revolutions to clear excess preservative oil from cylinders.

CAUTION

Ensure that the Master and Ignition Switches are OFF!

7. Install spark plugs -- torque to 11 Nm (8 ft/lbs).
8. Check fuel filter -- replace if necessary.

9. If returning to service after indefinite storage, fill fuel tank with correct grade of fuel.
10. Check fuel tank and fuel lines for moisture and sediment. Drain enough fuel to eliminate any moisture and sediment.
11. Check fuel tank breather is clear.
12. Perform a thorough pre-flight inspection.
13. Start and warm engine.

5.8 Operation in Winter

It is recommended to carry out an engine service prior to the start of the cold season. For selection of oil, consult the table of lubricants at Paragraph 2.5. Follow the following advice for operation at extremely low temperatures:

5.8.1 Carburettor Icing

It is important to distinguish between two kinds of icing:

- 1) Icing due to water in fuel, and
- 2) Icing due to high air humidity.

Re 1)

Water in fuel will accumulate at the lower parts of the fuel system & can lead to freezing of fuel lines, filters or jets. Remedies are:

- Drain, using fuel tank water drain.
- Ensure fuelling without traces of water. If in doubt, use a chamois as a filter.
- Install a generously sized water separator.
- Ensure that fuel lines do not permit the accumulation of water.
- Add up to 2% isopropyl to fuel. Note: Addition of alcohol raises vapour pressure and may aggravate vapour lock in warm weather; this practice should be used only when needed and not in warm weather.
- Prevent condensation of humidity, ie avoid temperature differences between the aircraft & fuel.

IMPORTANT

Fuels containing alcohol always carry a small amount of water in solution. In situations where there are changes in temperature, or where there is an increase in alcohol content, water (or a mixture of water & alcohol) may settle & could cause problems.

Re 2)

Carburettor icing due to humidity may occur in the carburettor venturi & leads to performance loss due to changes in the mixture.

The only effective remedy is to preheat the intake air by use of the Carburettor Heat Control.

WARNING

When using auto fuels, ensure all components of the fuel delivery system are cooled to prevent fuel vaporization.

6.0 MAINTENANCE

6.1 Lubrication System

Oil Change, Oil Filter Change, Visual Check for Leaks.

- * Drain the oil while engine is still warm.
- * Change the oil filter at 100 hour inspection.
- * Fill with oil. Capacity is 3.5 litres (3.69 US Quarts)
- * Check oil level. The MAX mark must not be exceeded.
- * Use only registered brand oils meeting the specification detailed in Para. 2.5.

6.2 Air Intake Filter

Clean filter by removing from the intake housing & blowing compressed air against the direction of the intake flow.

For operation in heavy dusty conditions, clean air filter at shorter intervals than recommended for normal conditions.

A clogged filter will reduce engine performance as well as promote premature engine wear.

6.3 Carburettor Adjustment

Open idle mixture screw approximately 1-1/4 turns, fine adjust for a smooth idle. The determination of the main jet is carried out on a dyno at 107 ft above Mean Sea Level.

IMPORTANT

Check & oil carburettor joints & linkage

6.4 Compression Check

Measure compression using a compression tracer. Readings are taken with fully open throttle valve at engine oil temperature between 30 & 70 degrees C (90 to 160 degrees F).

If readings are below 6 bar (90 psi) a check of the pistons, cylinders, valves & cylinder heads must be undertaken.

Alternatives:

- * Pressure loss or leakage tester eg SUN or BOSCH tester; max. allowable pressure loss is 25%.
- * Checking by commonly used pressure difference method; place orifice of 1 mm ID and 3mm length between the two pressure gauges. This will give the same result as with the above instrument. Max. pressure drop is 25%.

6.5 Spark Plugs

Do not use steel or brass brushes for cleaning & never sandblast plugs.

Clean with plastic brush in a solvent.

Check electrode gap & if necessary, adjust to 0.55 - 0.6mm (0.022" - 0.024") by carefully bending the electrode. Recommended Plugs: NGK D9EA

IMPORTANT

Only tighten spark plugs on cold engine & only to the torque values shown in para. 9.0 using appropriate anti-seize compound

Note: When plugs are removed from a warm engine, the following are indicators:

Light Coloured to Brown :- Plug & calibration is correct.

Velvet Black:- Mixture too rich. Check choke. Insufficient air intake. Check for clogged air filter.

Oily, Glossy Coating:- Misfiring. Too much oil in combustion chamber. Worn cylinder & piston rings.

Whitish with Melt Droplets:- Mixture too lean. Leaking valves.

6.6 Exhaust System

Visual check for damage, leaks & general condition.

6.7 Bolts and Nuts

Check for tightness, re-torque if necessary (see para. 9.0).

6.8 Tappet Adjustment

Tappets must be adjusted to: Inlet 0.254mm (.010")
 Exhaust 0.254mm (.010")

Adjust the tappets when the engine is cold. Head torqued to 24 ft lb. when cold. Carry out this adjustment after five hours of operation and again after ten hours of operation. At the 25 hour inspection this is done again.

CAUTION

Continued operation with incorrectly adjusted tappets will result in damage to valves, valve seats, valve guides & overhead gear.

6.9 Tachometer and Sender

Many apparent engine problems can be caused through inaccurate tachometers. Where engine performance is observed to be outside limits, the tachometer should be checked against a calibrated instrument. Tachometer sender gap is 0.4mm (0.016").

6.10 Additional Checks

Check engine for ease of starting. Conduct idle test run.

7.0 SERVICE & REPAIR

7.1 Engine Overhaul and TBO

These are carried out only by the manufacturer, Jabiru Aircraft Pty Ltd or by a specifically approved Jabiru Engine Service Centre (contact Jabiru for details).

The engine must be sent in a complete state, with logbook, to Jabiru (or the Approved Service Centre) after reaching the TBO limit.

Changes to the TBO due to operational experience will be advised by Jabiru through Service Bulletins.

7.2 ENGINE REMOVAL PROCEDURE

<u>No.</u>	<u>Operation</u>	<u>Tools</u>
1	Remove Spinner and Propeller	Phillips Screwdriver 1/2" Socket 1/2" Spanner
2	If fitted, remove Carby Heat hose from Hot Box Muffler	Screwdriver
3	Remove Air Inlet Hose from Carburettor and blank off Carburettor and Air Cleaner	Screwdriver 2 Plugs
4	Disconnect Throttle Cable	Long Nose Pliers
5	Disconnect Choke Lever	Long Nose Pliers
6	Remove Oil Breather Line	Screwdriver
7	Remove Fuel Line from Fuel Pump and plug Fuel Line and Fuel Pump	Screwdriver 1/4" Plugs
8	Remove Starter Motor Cable from Solenoid	7/16" R/OE
9	Disconnect Earth at Battery	10mm R/OE
10	Remove Oil Pressure Gauge Lead	-
11	Remove Oil Temperature Gauge Lead	-
12	Remove Hourmeter Lead	Screwdriver
13	Remove Cylinder Head Temperature Gauge Lead	-
14	Remove Exhaust Gas temperature Gauge Lead	-
15	Remove Tacho Lead	-
16	Remove Left and Right Ignition Coil Leads	-
17	Remove Air Ducts	-
18	Remove Muffler Assy	3/16" Ball End Allen Key
19	Undo Engine Mount Bolts	7/16" Tube Socket 7/16" Spanner
20	Remove Engine from Engine Mount Frame	-

7.3 ENGINE DISASSEMBLY

<u>No.</u>	<u>Operation</u>	<u>Tools</u>
1	Mount Engine on an engine stand in vertical position	
2	Remove Spark Plugs	Spark Plug Socket
3	Remove Oil Pressure Sensor	17mm Spanner
4	Remove Oil Filter	-
5	Oil Pressure Valve may be removed by removing snap ring (1)	Snap Ring Pliers
6	Extract Valve Seat (1), Valve (1), Spring (1)	-
7	Remove Oil Pump Assembly (Housing, Rotor, Stator & Backing Plate)	1/4" Allen Key
8	Remove 4 capscrews in front oil seal carrier and break seal on crankcase	3/16" Allen Key
9	Remove Fuel Line and Carburettor	Screwdriver
10	Remove Fuel Pump, Gasket and Push Rod	1/4" Allen Key
11	Remove Distributor Cap Clamps, Caps and Rotors	5/32" Allen Key
12	Remove Starter Motor	3/16" Allen Key
13	Remove Alternator Mount	7/16" Socket 5/16 Ring O/End Spanner
14	Remove Ignition Coils from Alternator Mount	3/16" Allen Key
15	Remove Flywheel	1/4" Allen Key
16	Remove Gearbox Cover	3/16" Allen Key
17	Remove Engine Mount Plate	1/4" & 3/16" Allen Key
18	Remove Crankshaft Timing Gear	-
19	Remove Lower Induction Pipes	Screwdriver

20	Remove Sump	3/16" Allen Key
21	Remove Exhaust and Induction Pipes	3/16" Allen Key
22	Remove Tappet Covers	3/16" Allen Key
23	Remove Rocker, Rocker Shafts and Push Rods	3/16" Allen Key
24	Remove Cylinder Head	1/4" Allen Key 1/2" Socket
25	Remove Push Rod Tubes	-
26	Remove Cylinder	7/16" Crowsfoot

Removal of Piston

27	Remove 1 Wrist Pin Circlip	-
28	Remove Wrist Pin (keep pin matched with its piston)	-
29	Remove Piston Rings (keep rings matched with its piston)	-
30	Repeat Operations 27-30 on other pistons if required.	-

Crankcase Disassembly

31	Remove main Stud Nuts on Front 2 studs	7/16" Socket
32	Double check that every bolt is removed and sump, gear case engine mount plate, oil pump and Front Oil Seal Carrier is removed	-
33	Tap Crankcase slightly and open Crankcase by removing half Crankcase	Soft Faced Hammer
34	Remove both Crankcase Halves of Crankshaft and Remove Cam Shaft	-
35	Remove Valve Lifters (12) <i>Note - Keep valve lifters matched to each Crankcase half.</i>	-

- 36 Remove Thrust Washers (front and rear)
 - 2 without tang on right half case
 - 2 with tang on left half case
 Note - visually check for marks or scratches
 - keep matched to their seats -
- 37 Remove Main Bearing Inserts (16) -
 Note - visually check for marks or scratches
 - keep matched to seats
- 38 Remove Crankcase dowels. Remove O'Rings and Discard -
 Note - do not attempt to remove studs as they
 are loctited in with 620 loctite
- 39 Remove Oil Gallery Plugs and Oil Pressure Sender. -
 Remove Oil Relief Valve.

Cylinder Head Disassembly

- 40 Remove Valve Springs and Valves Valve Spring
Compressor
- 41 Remove Push Rod Circlips and O'Rings Internal Circlip Pliers

Gearbox Cover Disassembly

- 42 Remove Distributor Shafts -
- 43 Remove Oil Seals -

Crankshaft & Camshaft Disassembly

- 44 Remove Bolts from Conrod 1/4" Allen Key
 Note - Rods will need to be heated 3/8 Ratchet
 - Big End Bolts are Discarded on Removal Hot Air Gun Rags
- 45 Remove Rod Bearing Inserts -
 Note - visually inspect for marks and scratches
 - keep matched to their seats
- 46 Remove Camshaft Gears. Discard Camshaft Bolts. -
 Remove welsh plug in rear of camshaft.

7.4 3300 ENGINE OVERHAUL

Inspection and Assembly of Sub-Assemblies

- 1 Sub-Assembly A - Crankshaft, Prop Mount and Con Rods.
- 2 Sub-Assembly B - Crankcase and Camshaft.
- 3 Sub-Assembly C - Pistons, Cylinders and Cylinder Heads.
- 4 Sub-Assembly D - Sump and Oil Pump
- 5 Sub-Assembly E - Flywheel, Ignition Coils and Alternator
- 6 Sub-Assembly F - Gear Case
- 7 Fuel Pump and Carburettor
- 8 Final Assembly of Sub-assemblies
- 9 Run In

Jabiru 3300 Component Inspection and Assembly Procedure

7.4.1 Sub-Assembly A - Crankshaft, Prop Mount and ConRods

- A1
- 1) Remove welsh plugs from crankshaft
 - 2) Clean conrods and crankshaft
Note - Make sure all old loctite is removed from threads
 - 3) Strip paint off prop flange and crankshaft.
 - 4) Magnet particle inspect crankshaft, prop flange, cam and conrods
- A2 Measure crankshaft and record in Build Sheet.
- A3 Inspect Oil Holes for Cleanliness and insert new front welsh plugs (2 off) and rear welsh plug.
- A4 Inspect prop flange. Paint prop flange and end of crankshaft to prevent rusting.
- A5
- 1) Magnet Particle Inspect conrods for cracks.
 - 2) Fit bearings with a light smear of bearing blue on back of shells.
 - 3) Torque Caps to 18 lbs (with new bolts)
 - 4) Measure Big End Bearings. Record in Build Sheet.
 - 5) Measure Piston Pin Bore. Record in Build Sheet.
 - 6) Remove caps and check bearing back contact (Must be at least 90%)
 - 7) Remove all blue and thoroughly clean surfaces. Refit bearing shells.
- A6 Temporarily mount prop flange to crankshaft and mount to stand vertically.
(Flange is removed later to fit front oil seal)
- A7
- 1) Spray conrod bolts and conrod bolt threads with Loctite 7471 primer and allow to dry.
 - 2) Mount conrods to crankshaft. Use plenty of oil on journals. Closest to prop flange is number 1. Pins to prop drive. Use Loctite 620 on rods and bolts torque up to 24 NM (18ft/lbs).

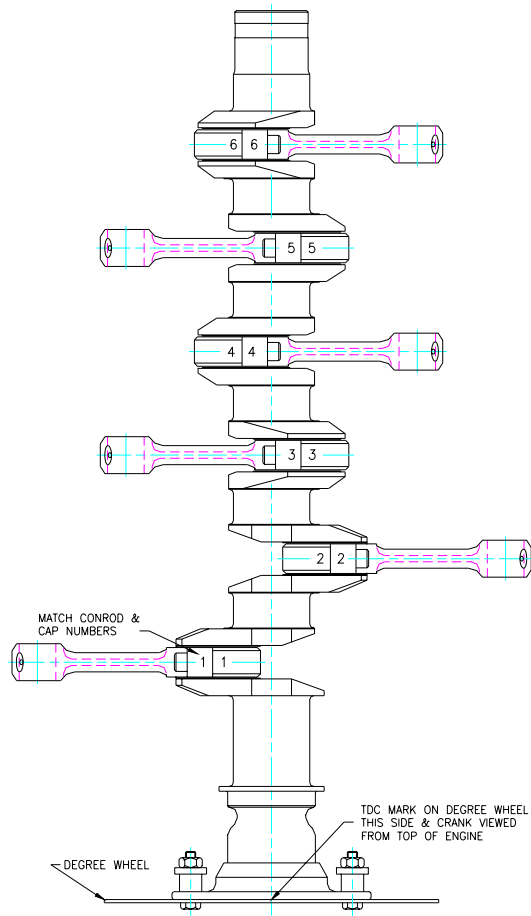

Drawing 9478083

- A8
- 1) Clean and visually inspect camshaft.
 - 2) Measure journal diameter.
 - 3) Measure lobe lift.

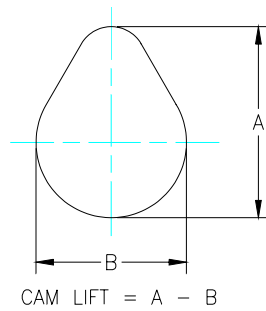

Drawing 9433064/1 CAM LIFT MEASUREMENT

Drawing 9433064

- 4) Inspect fuel pump lobe for wear.
- 5) Spray camshaft rear gears and bolts with Loctite 7471 Primer.
- 6) Fit gears and new bolts. Use Loctite 620 torque to 12 ft lbs & Lock Wire.
- 7) Fit end welsh plug.

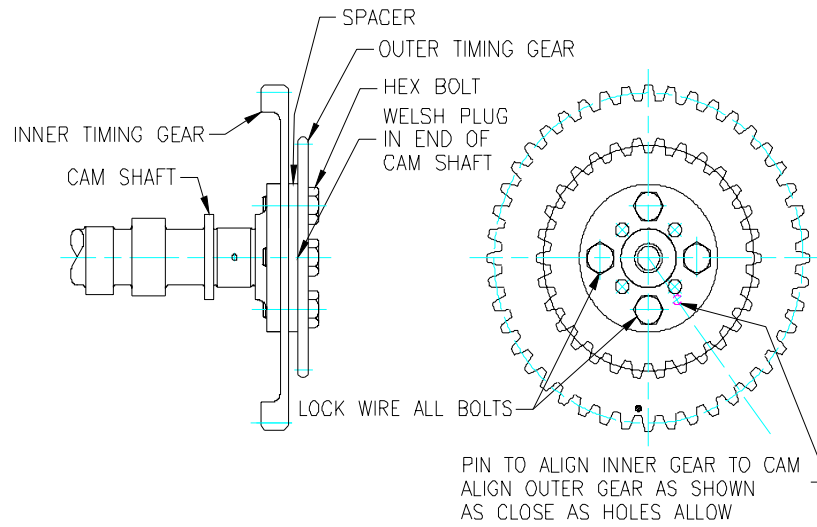

Drawing 9448064

A9 Stage Inspection by 2nd person of Sub-Assembly

3300 Component Inspection and Assembly Procedure

7.4.2 Sub-Assembly B – Crankcase and Camshaft

- B1
 - 1) Clean crankcase, remove old Loctite and clean oil galleries.
 - 2) Visually inspect crankcase.
- B2 Fit inner stud O Rings with a small smear of rubber grease.
- B3 Inspect all studs for tightness threads and stretching
- B4
 - 1) Check oil suction pipe for security, replace o ring.
 - 2) Fit all dowles lightly. Lubricate o rings before fitting dowel.
- B5 Fit oil relief valve assembly, oil pressure sender and front plug/hourmeter switch.

Drawing 9435064

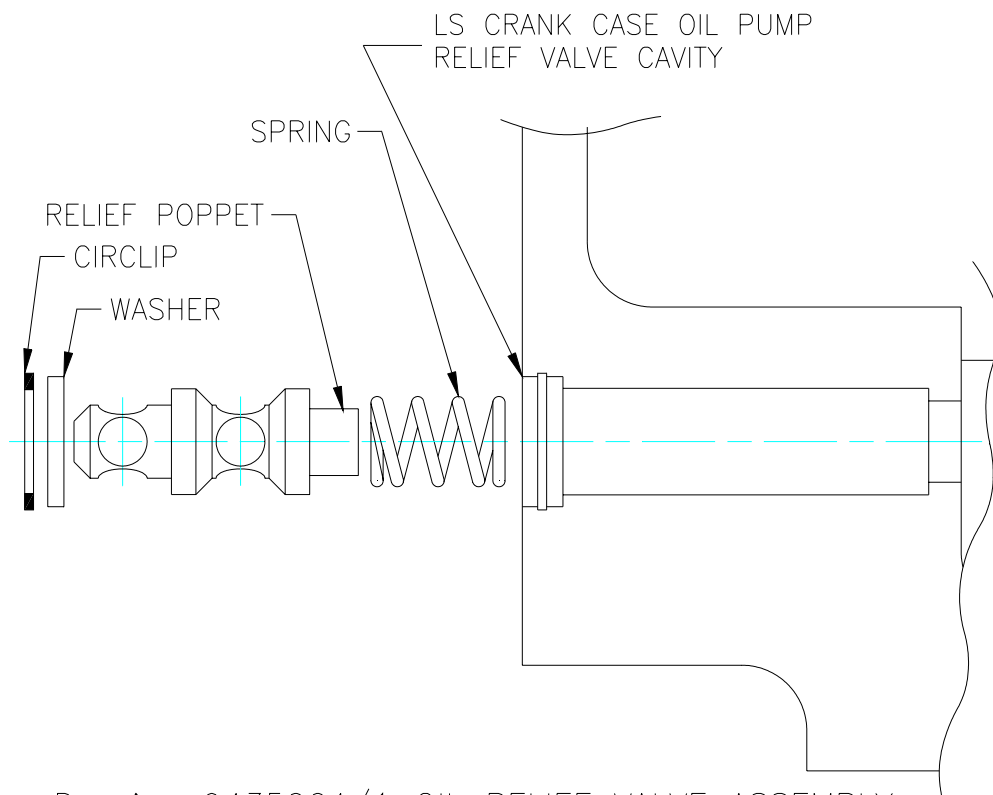

Drawing 9435064/1 OIL RELIEF VALVE ASSEMBLY

- B6
 - 1) Lightly blue bearing shells and one crankcase half.
 - 2) Fit bearing shells.

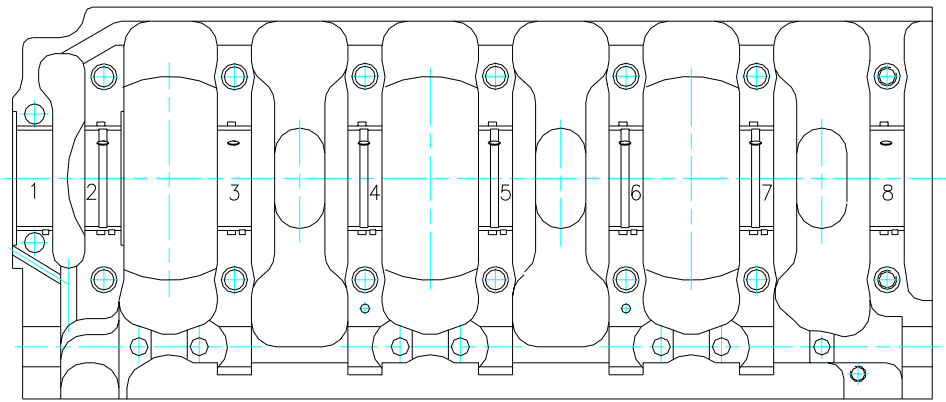

- | | |
|------------------|------------------|
| 1: PLAIN | 5: GROOVE & HOLE |
| 2: GROOVE & HOLE | 6: HOLE |
| 3: HOLE | 7: GROOVE & HOLE |
| 4: GROOVE & HOLE | 8: HOLE |
- BEARING POSITION & TYPE

Drawing 9441064

- B7 1) Make spacers as per drawing.

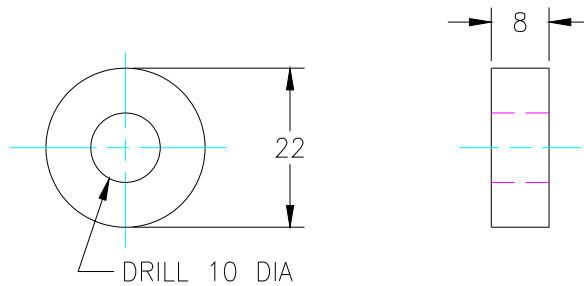

Drawing 9442064/1 SPACER FOR MEASURING CRANKCASE

Drawing 9442064

- 2) Join crankcase halves.
- 3) Put through studs in case.
Note the cylinders by themselves can be used as spacers. It is just a bit harder to measure the main tunnels.
- 4) Fit old nuts and torque to 40 NM (30 ft/lbs) in two stages.

B8 Measure main tunnel and cam tunnel and record in build sheet.

- B9
- 1) Disassemble.
 - 2) Remove shells and check back contact (must be at least 90%).
 - 3) Check mating surface on crankcase.
 - 4) Remove all blue and thoroughly clean surfaces. Refit bearing shells.

B10 Measure cam lifters and bores and record on build sheet. Check Lifter face for excessive scuffing. Oil and refit. Use a small amount of Molybdenum disulphide grease on lifter faces.

B11 Check cam shaft end float in both halves. Record in build sheet.

B12 Check crankshaft end float in both halves and record in build sheet.

Jabiru 3300 Component Inspection and Assembly Procedure

7.4.3 Sub-Assembly C - Pistons, Cylinders and Cylinder Heads

Cylinder Head Clean Up

- C1
- 1) Clean oil off heads.
 - 2) Dip heads in a cold dip solvent (i.e. Redik dkt Degreaser - Decarboniser - Paint stripper) as per manufactures instructions to remove all carbon deposits.
 - 3) Note. The heads can be bead blasted, but care must be taken.
 - 4) Wire buff valves.
 - 5) Clean all other parts.

Cylinder Head Inspection and Repair

- C2
- 1) Inspect cylinder head for flatness. If sealing surface show signs of leakage it may need refacing. When refacing, remove only the minimum to clean up.
 - 2) Measure valve guide wear.
 - 3) If wear is excessive remove guides. Measure valve guide bore in the head. The new guide must have at least 0.05mm (0.002") interference on the outside diameter.
Note - The standard guide has no dimples in top (P.N.4518064) In (P.N. 4519064) Ex
0.05mm (0.002") has one dimple
0.05mm (0.004") has two dimples
0.05mm (0.006") has three dimples
 - 4) Press guides back in.
Note - Oil hole must go up
 - 5) Special note Guides:
Guides are installed at 7.05mm bore diameter. Guides from 7.08mm can cause oil usage in the engine. (Max valve stem to guide clearance is 0.12mm).

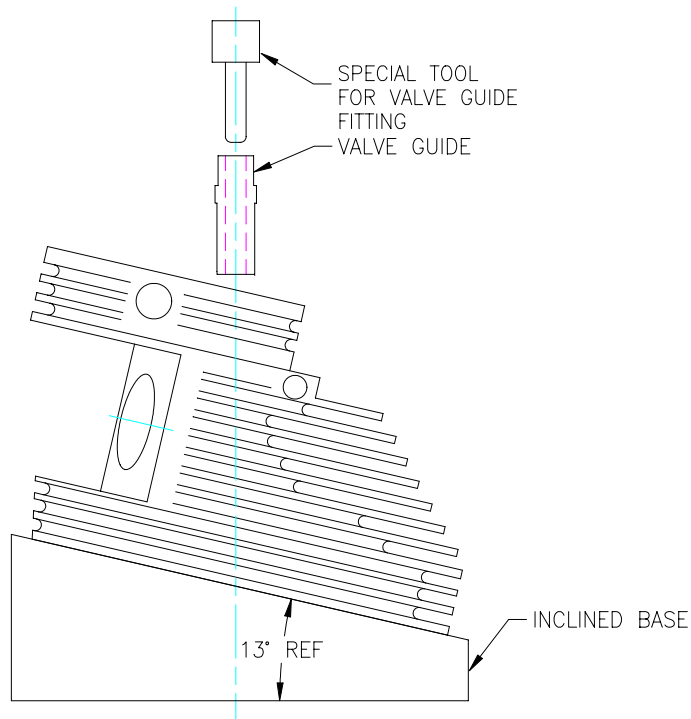

Drawing 9446064/1 VALVE GUIDE REPLACEMENT

Drawing 9446064

5) Mount head up and cut seats as per drawing.

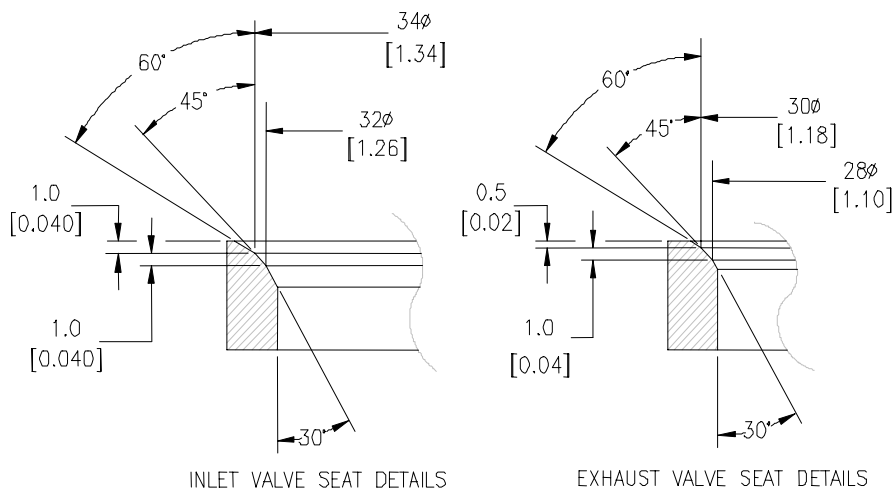

Drawing 9445064

Note - When cutting seats cut enough to clean up but try to remove as little as possible. This will give maximum number of overhauls on heads.

- 6) Use ground and serviceable valves to check seat contact.
Note - If machine has a vacuum tester, vacuum test valves.
- 7) Heads of valves must be above the level of the combustion chamber. If they are below, the valve seats and valves must be replaced.
- 8) Measure valve stem for wear. Record in build sheet if within limits or replace valves.
- 9) Grind valve seats. If margin is too small, replace valves.

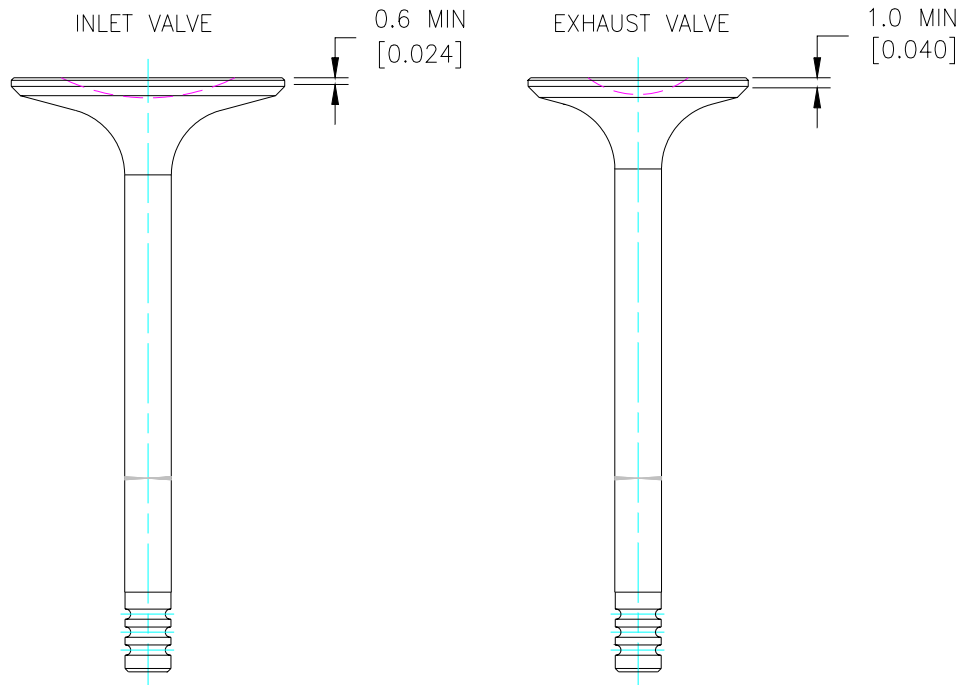

Drawing 9444064/1 VALVE DETAILS

Drawing 9444064

- C3
- 1) Clean heads and valves ready for assembly.
 - 2) Measure valve springs. Replace if they are shorter than service limits.
40.0mm – 41.8mm (1.580" - 1.688")

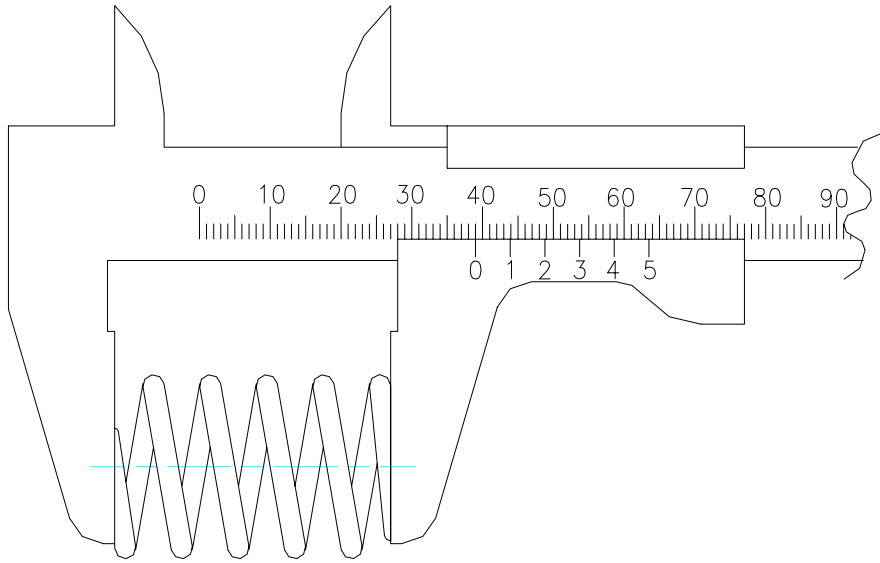

Drawing 9443064/1 VALVE SPRING MEASUREMENT

Drawing 9443064

- 3) **Inspect valve spring seats, valve spring retainers and valve collets. Replace any that show signs of wear.**
- 4) **Lube valves well. Install valves, valve spring seats, springs, retainers and collets.**

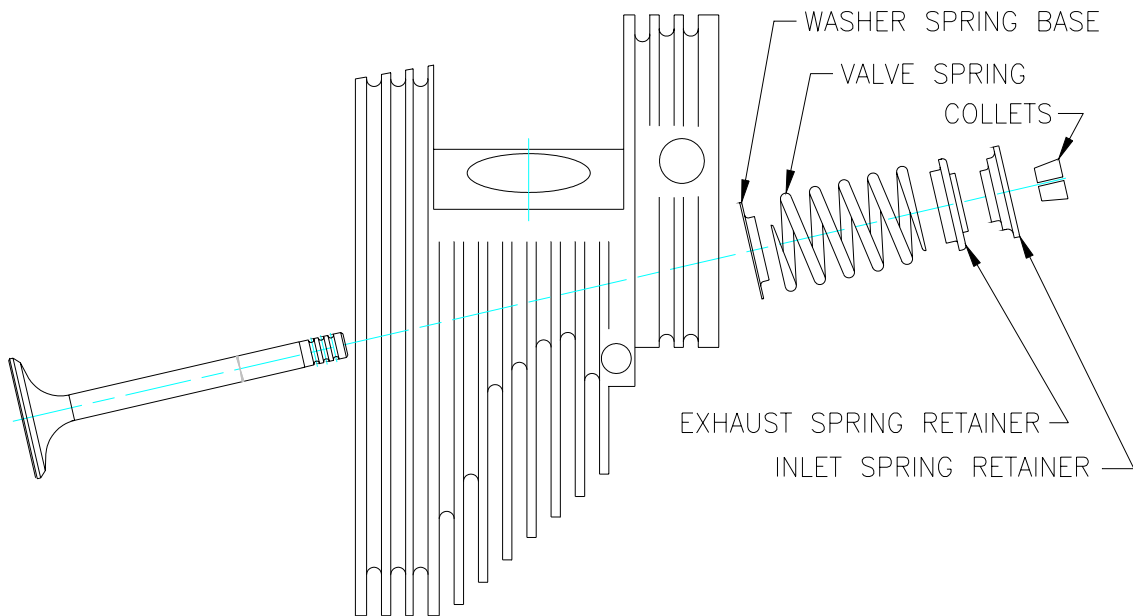

Drawing 94470641/1 VALVE ASSEMBLY

Drawing 9447064

C4 Install Push Rod Tube O'Rings with a small amount of rubber grease.

Rocker Assembly

- C5
- 1) Disassemble and clean off all carbon.
 - 2) Inspect rocker tip for wear. Replace any with excessive wear.
 - 3) Measure bushes and record on build sheet.
 - 4) If over service limits, replace.

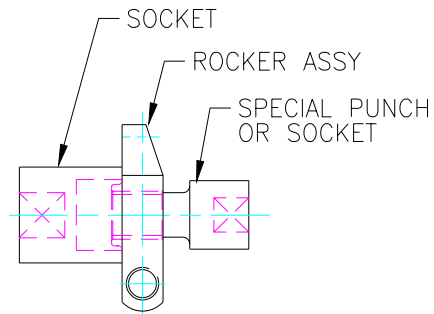

Drawing 9449064/1 ROCKER BUSH REMOVAL

Drawing 9449064

- 5) Clean off old Loctite from rocker bore.
- 6) Press in Bushes. These are a 15mm wide glasier type bush.
- 7) Measure rocker shafts for wear and inspect for scratching, scuffing etc.
Record in Build Sheet.

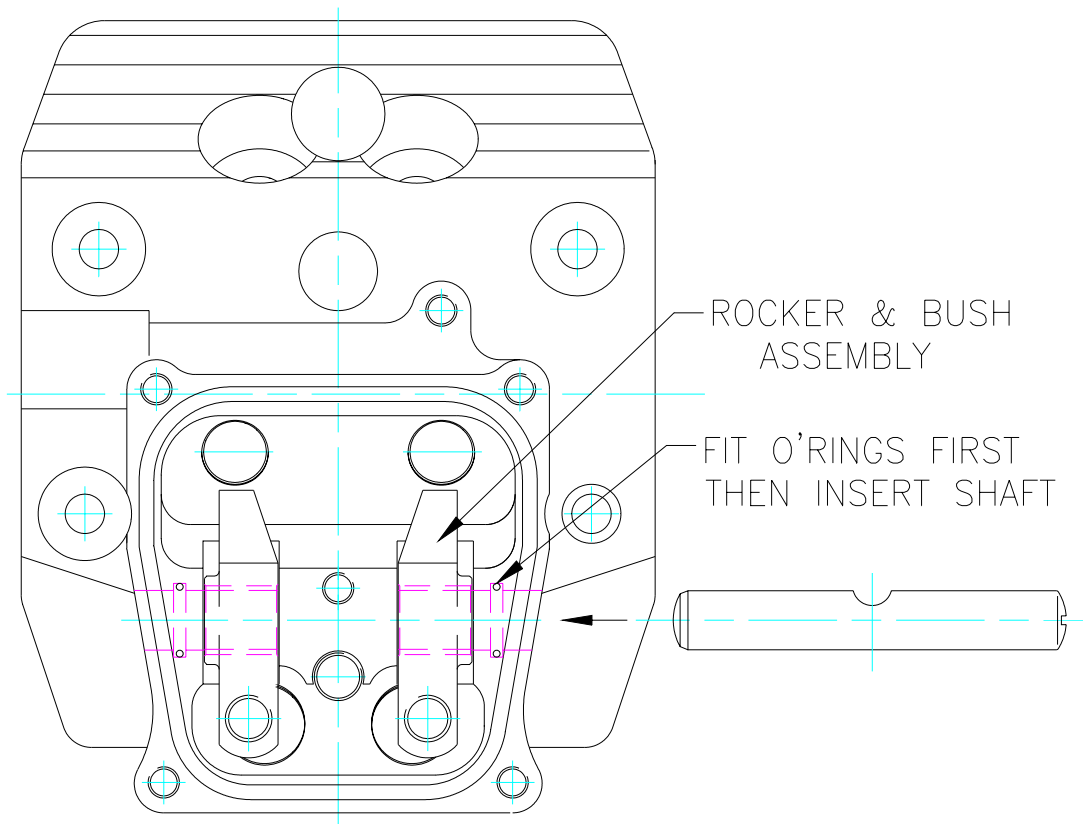

Drawing 9449064/1 ROCKER ASSEMBLY

Drawing 9449064

- 12) Put capscrew through clamp hole and check rocker end float. Must be 0.1 to 0.4mm (0.004" to 0.010"). Face off outside bushes to adjust.
- 13) Clean up, oil well and reassemble.

Cylinders

- C6 1) Clean and visually inspect.
- 2) Mount cylinders in honing machine by base and hone with Sunnen mm 33-J85 Stone

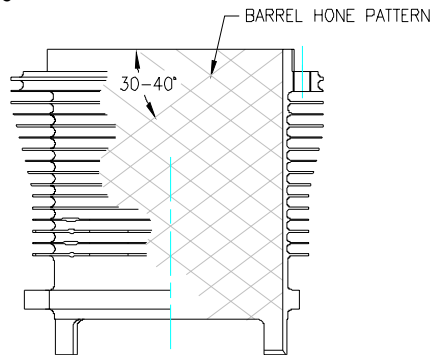

Drawing 9436064

- 3) Measure and record in Build Sheet
- 4) Bead blast cylinder outer to remove all old paint and rust.
- 5) Etch prime and paint with high temperature black paint.
- 6) Run 5/16 UNF Tap through head threads to remove all beads and to insure that head bolts torque up fully.
- 7) Clean in kero then in hot soapy water to remove all honing oil etc.
Note: Once cleaned, oil up cylinders straight away. Store in a cool dry place in a sealed container.

Pistons

- C7
- 1) Clean oil out of pistons.
 - 2) Dip Pistons in cold dip solvent (i.e. Redik DKT degreaser - decarboniser - paint stripper) as per manufacturers instructions to remove all carbon.
Note: The head of the piston can be bead blasted, but never bead blast the ring grooves, piston skirt and piston pin bores.
 - 3) Use an old ring to clean carbon out of ring grooves but care must be taken not to scratch grooves. Any scratching will cause Gas Leakage past the rings. A piece of 2mm (0.080") perspex can also be used as it is kinder to the pistons.
- C8
- 1) Clean thoroughly.
 - 2) Visually inspect pistons for cracks or damage.
 - 3) Measure pistons and record in build sheet.

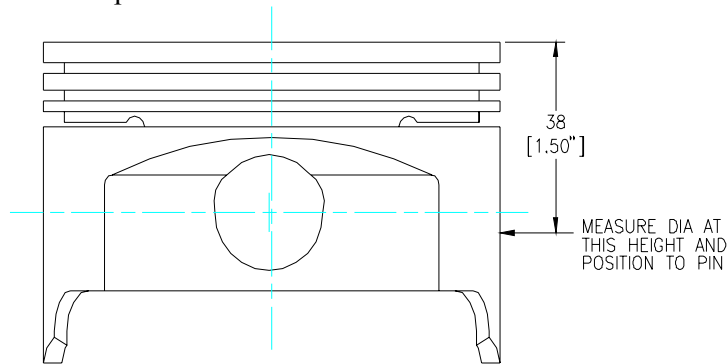

Drawing 9434064

- (i) Clean inhibitor off new rings.
- (ii) Measure end gap of rings in the cylinder and record in build sheet.
- (iii) Fit rings with dots up
Note: End of oil ring expanded must be butted together.
- (iv) Fit pistons in cylinders. Oil Ring should only just enter so piston pin can be fitted later.
Note: Arrows on inside of pistons point in direction of rotation. Oil Rings and pistons and bore well.
- (v) Fit front piston pin circlip.
- (vi) Fit cylinder base O Ring.
- (vii) Seal up in plastic bags ready for final assembly.

Jabiru 3300 Component Inspection and Assembly Procedure

7.4.4 Sub-Assembly D - Sump and Oil Pump

Sump

- D1 1) Clean sump and remove all gasket eliminator.
2) Inspect oil pick up.
- D2 Remove induction O Rings.
- D3 Inspect carburettor coupling replace if it is damaged or showing signs of deterioration.
Note: It is very important that the carburettor and coupling are free of oil. If there is any oil present at all, it is possible for the carburettor to slip out of the coupling
- D4 Fit new induction O Rings to Induction Pipes. Engines from S/N 68 used a bolt on swept chamber and new induction pipes.

Oil Pump

- D5 1) Inspect oil pump inner and outer for damage to rotor surfaces.
2) Measure rotor clearance.

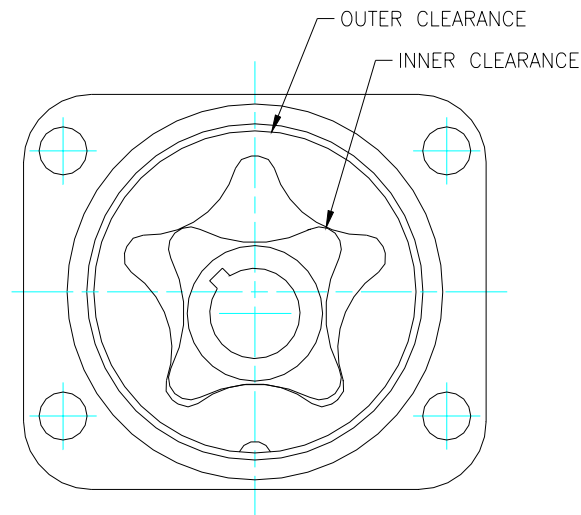

Drawing 9440064/1 OIL PUMP CLEARANCES

Drawing 9440064

Housing to Outer Rotor clearance 0.07mm to 0.14mm (0.003" to 0.006")

Inner Rotor to Outer Rotor 0.07mm to 0.14mm (0.003" to 0.006")

- 3) Fit Inner Rotor into Outer Rotor. Using straight edge check end clearance.
End Clearance 0.03mm to 0.006mm (0.0015" to 0.003")

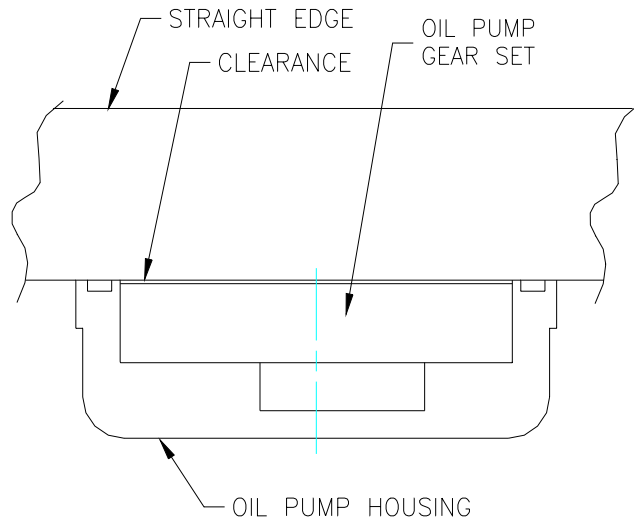

Drawing 9428064/1 OIL PUMP END CLEARANCE

Jabiru 3300 Component Inspection and Assembly Procedure

7.4.5 Sub-Assembly E - Flywheel & Ignition Coils & Alternator & Alternator Operation

Flywheel Inspection

- E1 Inspect ring gear for damaged teeth
- E2 Use a spring scale and a prop cap screw as per drawing to test ignition magnet strength. Pull off should be 1.5 to 2.5 kg (3.3 to 5.5 lbs)

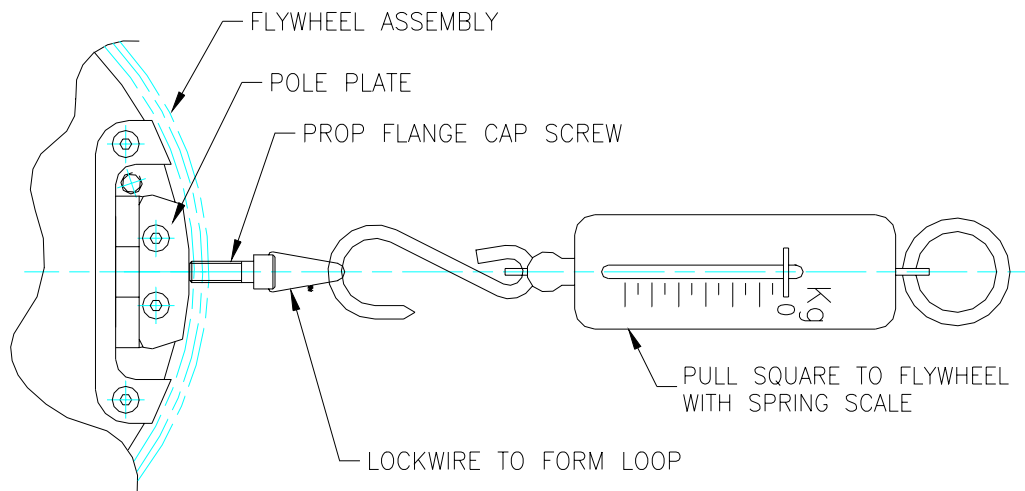

Drawing 9437064/1 MAGNET PULL TEST – FLYWHEEL

Drawing 9437064

- E3 Use spring scale and prop cap screw as in E2 to test alternator magnets. Pull off should be 1.5 to 2.5 kg (3.3 to 5.5 lbs).

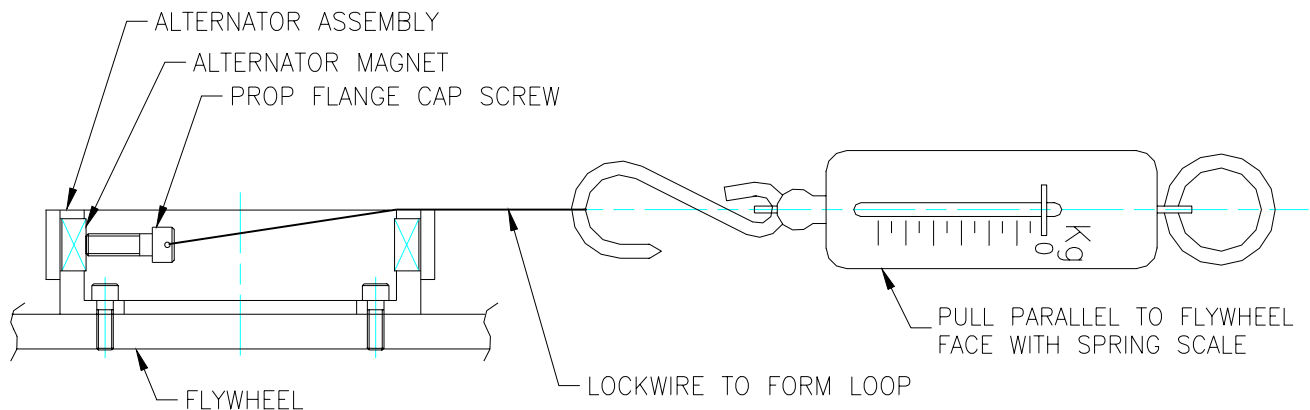

Drawing 9438064/1 MAGNET PULL TEST – ALTERNATOR

Drawing 9438064

Ignition Coil Inspection

- E4 1) Using a multimeter measure the primary resistance (from the earth terminal to the iron core). It should be 0.8 R to 1.0 R.

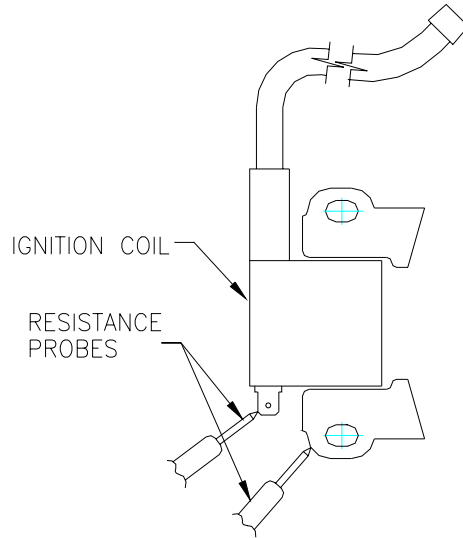

Drawing 9439064/1 IGNITION PRIMARY RESISTANCE

Drawing 9439064

- 2) Measure the secondary resistance (from the high tension lead to the iron core) it should be between 5.9 KR to 7.1 KR.

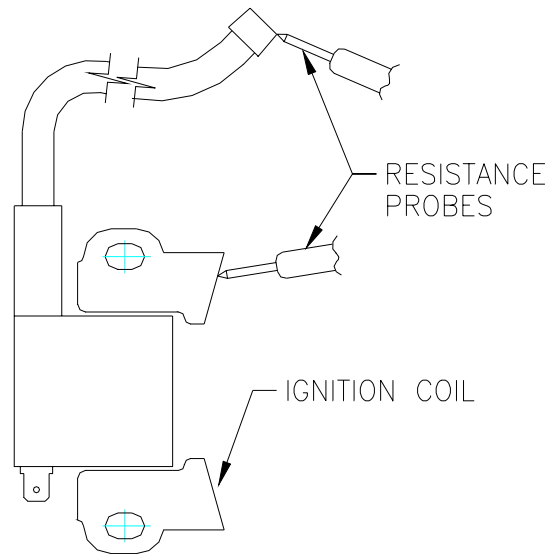

Drawing 9439064/1 IGNITION SECONDARY RESISTANCE

Drawing 9439064

Alternator Inspection

- E5
- 1) Use multimeter to test resistance of windings. Resistance should be 0.5 to 1.1 R.
 - 2) Use multi meter to test resistance to ground. Resistance should be infinite.

Permanent Magnet Alternator (PMA) Operation

(1) Master Switch

(3) Main Bus Bar

(5) Battery

(7) Regulator

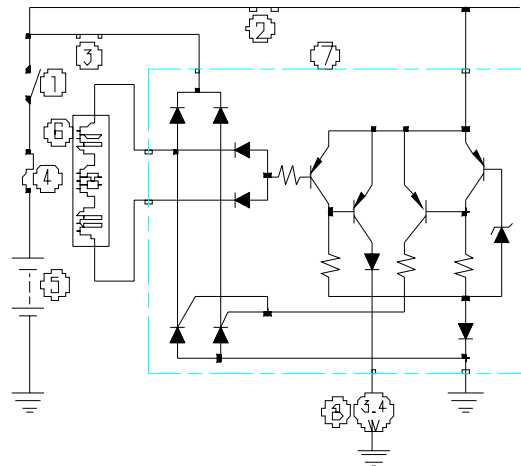

(2) Voltage Reference Line

(4) Fusible Link

(6) Permanent Magnet Alternator

(8) Charge Lamp

The charging system supplies electrical devices and also charges the battery while the engine runs. It consists of a Permanent Magnet Alternator (PMA) and a Regulator.

1. This permanent magnet alternator (PMA) is a 12 pole 3 phase rotating magnet type generator. It is a simple construction consisting of a stator and rotor. The rotor is made up of permanent magnets, alternator body and magnet retainer mounted on the flywheel.

The stator has 12 poles with coils and is mounted on the rear plate the stator goes inside the rotor.

2. Later engines use a single phase alternator of similar construction and a single phase regulator.

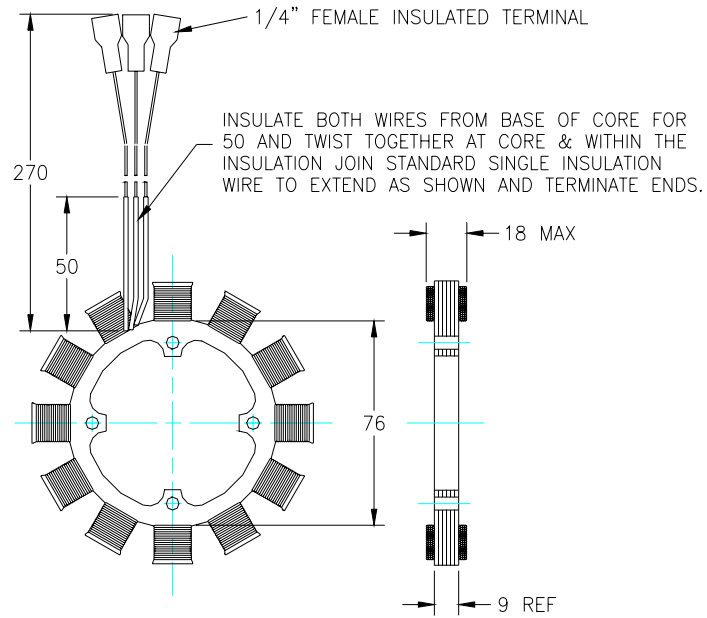

Drawing 4665084/1 ALTERNATOR CORE ASSEMBLY

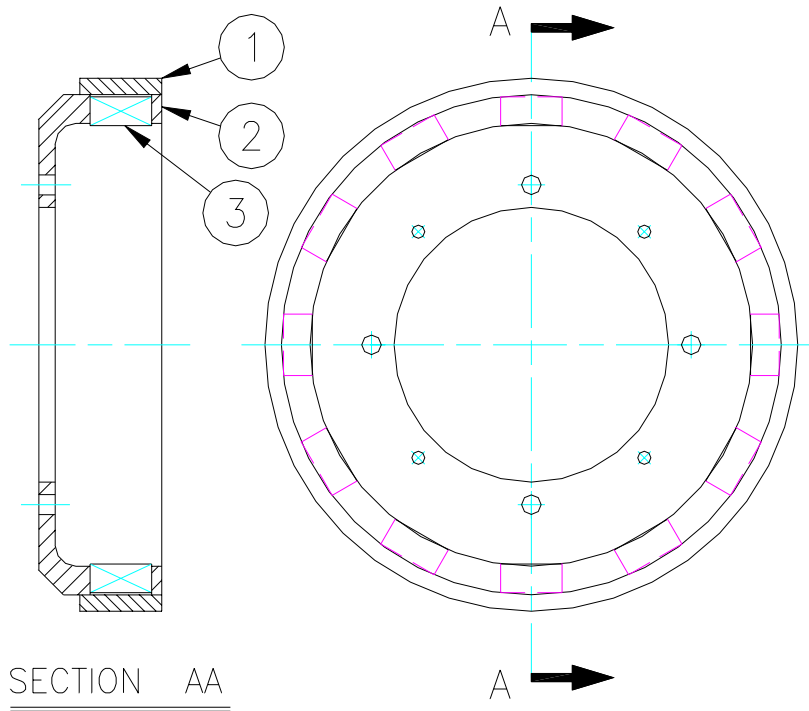

3	PM00656	MAGNET 15 ϕ X 7	12
2	4664184	ALTERNATOR BODY	1
1	4664284	MAGNET RETAINER	1
ITEM	PART No.	DESCRIPTION	QTY.

Drawing 4664084/1 ALTERNATOR BODY ASSEMBLY

2. Regulator

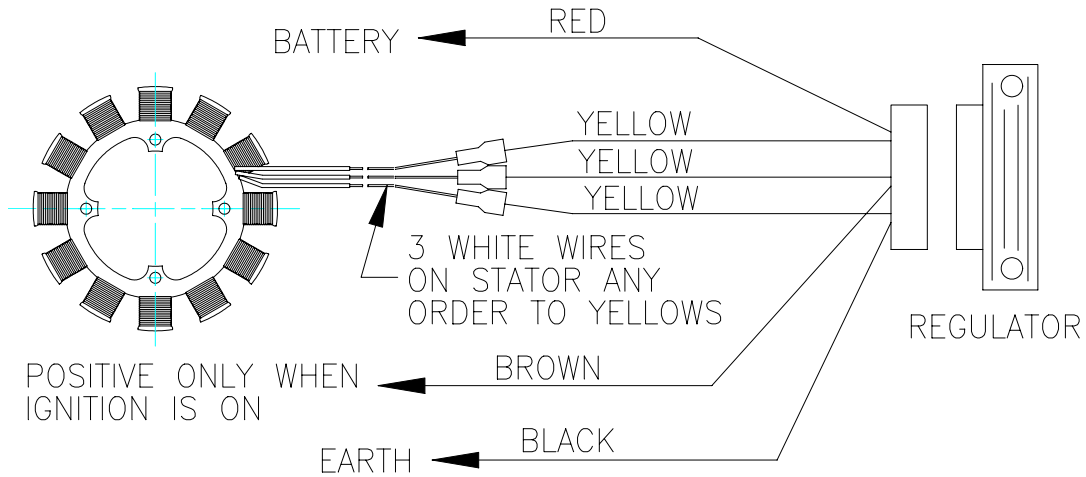

REGULATOR WIRING

The regulator performs rectification and voltage regulation.

The regulator converts A.C. into D.C. which flows through the power consuming circuits and the battery, and also charges the battery.

If however, the battery voltage exceeds a certain level, the D.C. is cut off from the charging circuit to prevent over charging.

Single Phase Diagram

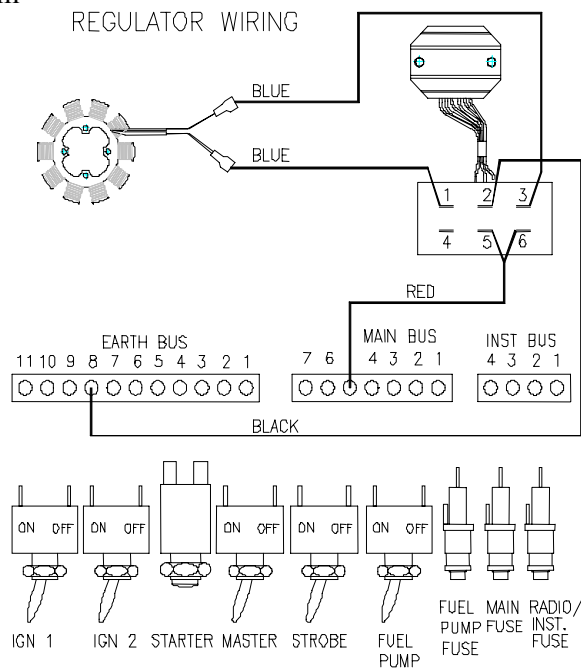

Jabiru 3300 Component Inspection and Assembly

7.4.6 Sub-Assembly F - Gear Case

- F1 Remove distributor shaft seals and rotor seal and discard.
- F2 Inspect Distributor shaft posts for signs of leaking.
Note: If there is no signs of leaking don't disassemble. But if it is leaking disassemble and clean off old master gasket. Inspect surfaces and reassemble.
- F3 Clean gear case distributor shaft and engine mount plate.
- F4 Measure distributor shafts and record on build sheet.
- F5 Measure distributor shaft posts and record in build sheet.
- F6 Fit shafts into gearcase and using a straight edge and feeler gauge measure end float. Record in build sheet.
- F7 Visually inspect gears for wear.
- F8 Fit seals to gear case.
- F9 Lube shafts and fit to gear case.
- F10 Fit rotors.
- F11 Visually inspect engine mount plate for
1) Damaged Threads
2) Wear from distributor shafts.
- F12 Seal up and store for final assembly.

Jabiru 3300 Component Inspection and Assembly

7.4.7 Sub-Assembly G - Fuel Pump and Carburettor and Carburettor Operation

Fuel Pump

The fuel pump on the 3300 engine is replaced as a complete unit at overhaul. It can be inspected for faults by removing the top half.

Things to look for are:

- 1) Stuck or leaking valves
- 2) Torn diaphragm
- 3) Weak springs
- 4) Broken actuating lever.

Carburettor Operation

The BING constant depression carburettor type comprises a cross draught butterfly-valve carburettor with variable choke tube, double-float system arranged centrally below the carburettor venturi and a rotary-valve type starting carburettor. It features a throttle slide which is suspended from a roller diaphragm and projects into the venturi. It changes the smallest cross-section ("choke tube") of the venturi as a function of the vacuum at this point.

MOUNTING

The carburettor is secured to the engine using a push-on connection which takes a flexible connecting piece with clamps. On the intake side the carburettor is provided with a socket having a diameter of 50mm and a length of 12mm for connecting an air filter or intake silencer.

FUEL INTAKE CONTROL

The float (40) of the carburettor consists of two plastic float elements joined by a metal hinge. The float is arranged centrally below the carburettor choke tube so that the carburettor can be tilted very far in all directions without impairing operation. The object of the float is to maintain the fuel level in the float chamber (44) constant. When the fuel has reached a specified level in the float chamber, then the float (40) mounted on pin (41) is lifted until the float needle (42) is pressed against the seat of the float needle valve, thus preventing any further supply of fuel. When the engine draws in fuel from the carburettor, the level in the float chamber (44) drops and so does the float. The float needle then opens the valve again and allows fuel to flow in from the tank. The float needle valve regulates the fuel supply in conjunction with the float but it does not act as a stop valve when the engine is at a standstill. Minute foreign bodies may be deposited between valve seat and needle tip, thus preventing complete closure of the valve. When stopping the engine, therefore, the fuel cock on the tank should always be closed. In addition the fuel should be filtered before it reaches the carburettor. The filter should be

selected so that foreign bodies greater than 0.1mm are filtered out and the fuel supply is not impeded to too great an extent.

The float needle (42) contains a spring-loaded plunger which contacts the float hinge. This absorbs vibrations on the float (40). In addition the float needle (42) is connected to the float hinge by the retaining spring (43) to prevent it from moving between float and valve seat and thus reducing the fuel supply. Spring and retaining guide make a considerable contribution towards keeping the fuel level in the float chamber constant.

When fitting a new float, the fuel level must be adjusted. When doing this care must be taken to ensure that the fuel needle spring is not compressed by the float weight. It is therefore advisable to put the carburettor in a horizontal position until the float just contacts the float needle. In this position the point on the float hinge is set in such a way that the float top edges are parallel to the top edge of the float chamber.

The float chamber (44) is secured to the carburettor housing by a spring yoke (45). A seal (46) is provided between float chamber and carburettor housing. The space above the fuel level is connected to atmosphere by two ducts. When these ducts are blocked, an air cushion forms above the fuel. The fuel will not lift the float sufficiently to close the needle valve and the carburettor overflows.

The float chamber (44) incorporates an overflow pipe to allow fuel to drain off if the specified level in the float chamber is exceeded substantially due to a leaking needle valve.

MAIN REGULATING SYSTEM WITH PRESSURE REGULATOR

The amount of mixture drawn in by the engine and thus its performance is determined by the cross-sectional area in the choke tube which is opened by the throttle valve (23). The throttle valve is secured to the valve shaft (24) by two screws (25). The end projecting from the carburettor housing carries the throttle levers (27) + (28) which are secured by the nut (3) and washer (29) to which the Bowden cable operating the throttle shaft is attached. The sealing ring (26) provides the seal between valve shaft and housing. The retaining arm (31) attached to the carburettor housing by means of screws (32) and washers (33) engages the notch in the valve shaft and thus prevents it from moving in axial direction. The return spring (35) whose action opposes the Bowden cable is attached between a bent-over tab at the lower end of the retaining arm and the throttle lever (28). If the throttle valve (23) is opened while the engine is running, the increased air flow in the choke tube results in a vacuum building up at the outlet of the needle jet (3) which draws fuel from the float chamber through the jet system. At low speeds and in particular in the case of four-stroke engines, this vacuum is not sufficient for an adequate fuel supply; it must therefore be increased artificially by using a pressure regulator. For this purpose the BING constant depression carburettor type 64 is provided with a plunger (13) operating in conjunction with a diaphragm (16); which reduces the cross-sectional area of the needle jet outlet by virtue of its own weight or, in some applications with the additional pressure from a spring (22), and thus increases air velocity and vacuum at this point.

The plunger (13) is located centrally in the cover (20) which is secured to the carburettor housing by screws (21). The diaphragm (16) is connected to the plunger (13) by a retaining ring (17) and four screws (18) and washers (19) each. The vacuum in the choke tube acts on the top of the diaphragm and the plunger via a bore (U) in the plunger (13) and attempts to lift the plunger against its own weight and spring (22). The considerably lower vacuum between air filter and carburettor is applied to the underside of the diaphragm via duct (V) as a reference pressure.

If the throttle valve (23) is opened when the plunger (13) is closed, then a vacuum will build up in the small cross-section at the bottom of the plunger (13) which is sufficient to provide a supply of fuel. The weight of the plunger (13) and the force of the spring (22) are matched in such a way that this vacuum will be maintained with increasing speed until the plunger has fully opened the carburettor cross-section. From this point onwards the carburettor acts as a throttle valve carburettor with fixed choke tube. The vacuum increases with increasing speed.

The space in the cover (20) above the plunger guide is vented through bore (D). Its diameter is designed in such a way that it acts as a restrictor for air flowing in and out and therefore acts as a vibration damper for the plunger.

On its way from the float chamber to the choke tube the fuel passes through the main jet (1), the jet carrier (10) and the needle jet (3); as it leaves the needle jet it is pre-mixed with air which is brought in from the air filter via an air duct (Z) and the atomiser (2) in an annular flow around the needle jet. This air flow assists the atomising process to form minute fuel droplets and thus favourably affects the fuel distribution in the intake manifold and combustion in the engine.

The conical section of the jet needle (4) which is secured to the plunger (13) with the retaining spring (14) and the serrated washer (15) engages into the needle jet (3). Depending on the dimension of the flat cone at the end of the jet needle, the annular gap between jet needle and needle jet is enlarged or decreased and thus the fuel supply is throttled to a lesser or greater extent. The jet needle (4) can be located in the plunger (13) in four different positions which, similarly to the jet needle cone, affect the amount of fuel drawn in. For example "needle position 3" means that the jet needle has been suspended from the retaining spring (14) with the third notch from the top. To achieve the height adjustment the jet needle is turned through 90° and pushed up or down, the retaining spring engaging the next notch in the jet needle. If the needle is suspended higher up, this will result in a richer mixture and vice versa.

In short the main regulating system is set using main jets and needle jets of various diameters and also jet needles, plungers and pistons of various types.

Between main jet (1) and nozzle stock (10) a washer (12) is provided which, together with the float chamber, forms an annular gap. In particularly severe operating conditions this ensures that the fuel is not spun away from the main jet.

A rubber ring (11) seals the nozzle stock (10) off from the carburettor housing to avoid any fuel being drawn in via the thread and thus bypassing the main jet.

IDLING SYSTEM

During idling and low-load running the throttle valve (23) is closed to such an extent that the air flow underneath the plunger (13) no longer forms a sufficient vacuum. The fuel is then supplied via an auxiliary system, the idling system, which consists of the idling jet (5), the idling air jet (LLD) - no spare part - and the mixture control screw (7) which is sealed off against the carburettor housing by the rubber ring (9) and secured by spring (8) to prevent it from becoming slack. The fuel passes through the idling jet (5) whose bore will determine the amount of fuel. Behind the jet bore the fuel mixes with air which is supplied via cross ducts in the jet throat from the idling air channel, the amount of air admitted being determined by the size of the idling air jet at the inlet of this duct. This initial mixture then flows through the idling outlet bore (LA), the cross-sectional area of which can be adjusted by the mixture control screw (7); it then reaches the choke tube via bypass or transition passages (BP) where it is mixed further with pure air.

Idling should always be with the engine at operating temperature. First the mixture control screw (7) is turned fully clockwise and then backed off by the number of turns specified for the particular engine. Turning in clockwise direction results in a leaner mixture and turning in anti-clockwise direction in a richer mixture.

The idling setting quoted serves as a guide only. The optimum will generally differ slightly. First select the desired idling speed by using the idling stop screw (34). When subsequently adjusting the mixture control screw - starting from the basic setting - a speed drop will be noticed in both directions. The optimum setting will generally be found half-way between the two settings at which this speed drop was noticed.

To facilitate the idling setting on engines having several carburettors where it is important that they are evenly adjusted, it is possible to connect a pressure gauge (in the simplest case a "U-tube pressure gauge") to a nipple below the throttle valve shaft bearing point which is normally closed off by screw (39). To select the idling speed, the idling screw (34) is in this case adjusted until the same vacuum is indicated for all carburettors. By slightly opening the throttle valve via a turning handle or the accelerator it is also possible to adjust Bowden cables or linkages evenly by making this vacuum comparison.

STARTING CARBURETTOR

BING constant depression carburettor is provided with a rotary valve starting carburettor as an aid for starting a cold engine using a Bowden cable. A disc (47) resting against the carburettor housing is turned via a shaft in the starting carburettor housing (48) so that the starting carburettor chamber into which air enters from the air filter side of the carburettor is connected to the engine side of the carburettor via a duct. The airport in the disc (47) is shaped in such a way that depending on the disc position, more or less air is drawn in. At the same time the disc opens the fuel system of the starting carburettor via bores matched to the disc position. The fuel flows from the float chamber through the starting jet into the vented starting chamber also contained in the float chamber (44) and from there through a riser where it is pre-mixed with air via transverse bores, into the starting carburettor. There it forms a particularly rich mixture with the air drawn in, and this

mixture bypasses the main carburettor to flow into the intake manifold of the engine direct. **During starting the throttle valve has to be closed to make sufficient vacuum available for the starting carburettor.** When the engine is at a standstill and also during normal operation the fuel level in the float chamber compartment incorporating the riser will be the same as in the rest of the float chamber. When starting with opened-up starting carburettor, the fuel will initially be drawn in from this compartment which forms a very rich mixture. The fuel supplied subsequently will only be the amount allowed through by the starting jet. This ensures that, once the engine has started, it is not supplied with an excessively rich mixture and stalled. The starting carburettor is therefore matched to any given engine by modifying the starting jet and matching the space behind it.

The starting carburettor is secured to the carburettor housing by four screws (51) and protected against ingress of dirt and water by the seal (50) between the two. The starting shaft is also sealed against the starting carburettor housing by a rubber ring (49).

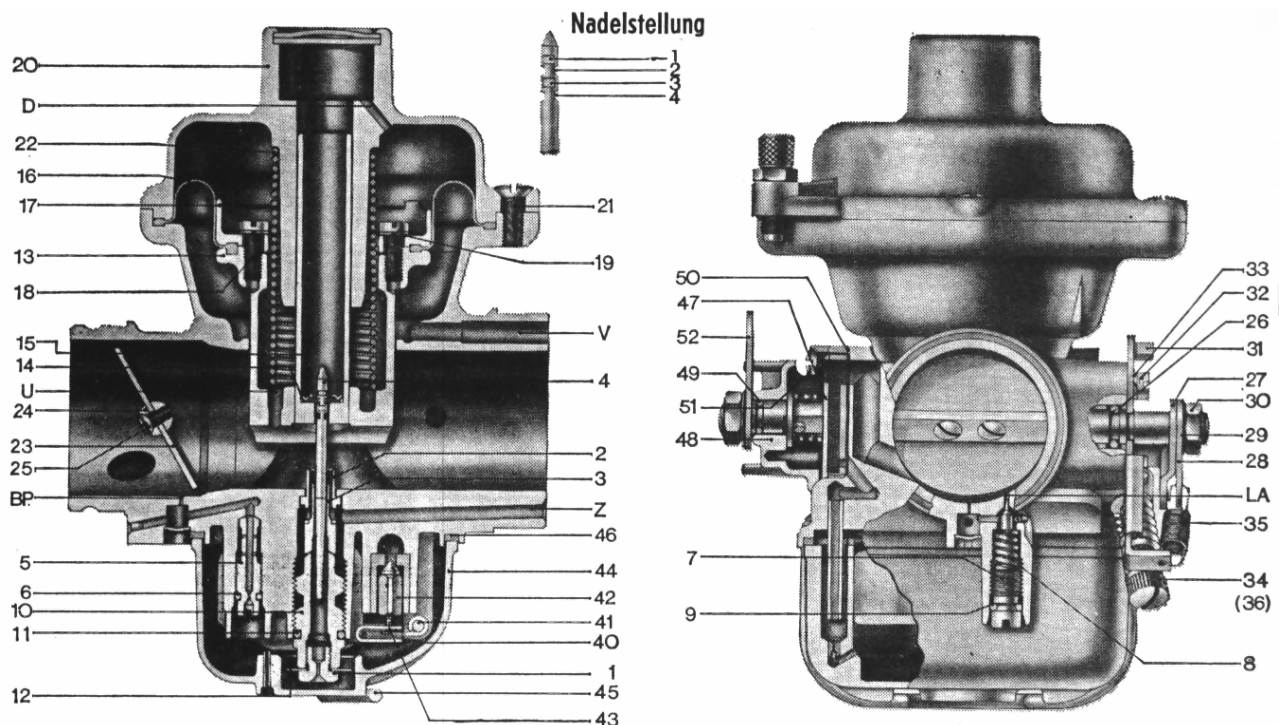

Carburettor Overhaul

Note: As a guide to overhaul read carburettor operation.

- G1 Disassemble carburettor
- G2 Using over haul kit replace all components
- G3 Record jet size
- G4 Record needle position
- G5 Reassemble carburettor

Jabiru 3300 Component Inspection and Assembly

7.4.8 Sub-Assembly H - Final Assembly

Crankcase Joining

- H1 a) Photocopy Degree Wheel (increase by 226% to bring to full size) then glue to stiff cardboard and cut out.

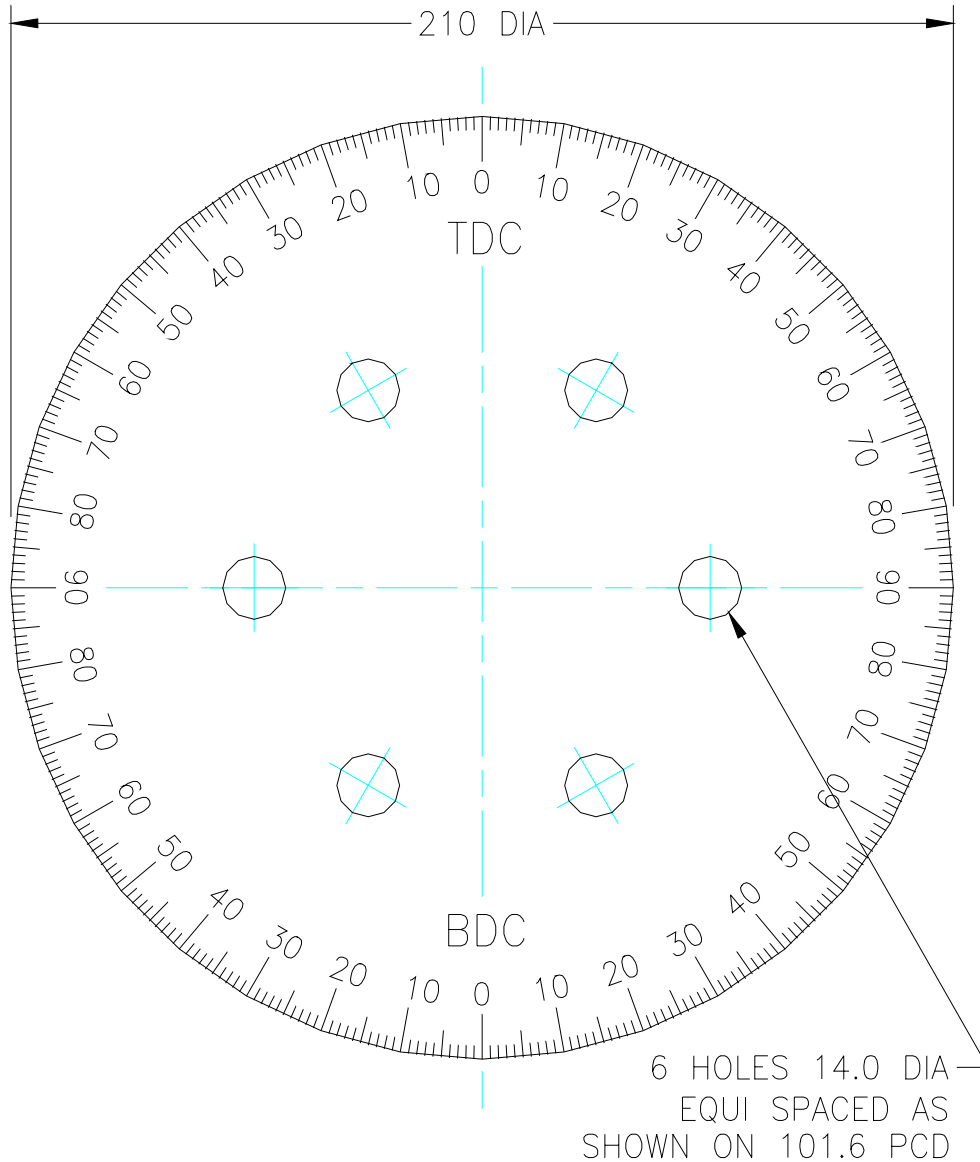

Drawing 9427063/1 DEGREE WHEEL

Drawing 9427063

- b) Stand crankshaft (Sub assembly A) up vertically, mounted on the prop flange as per drawing.

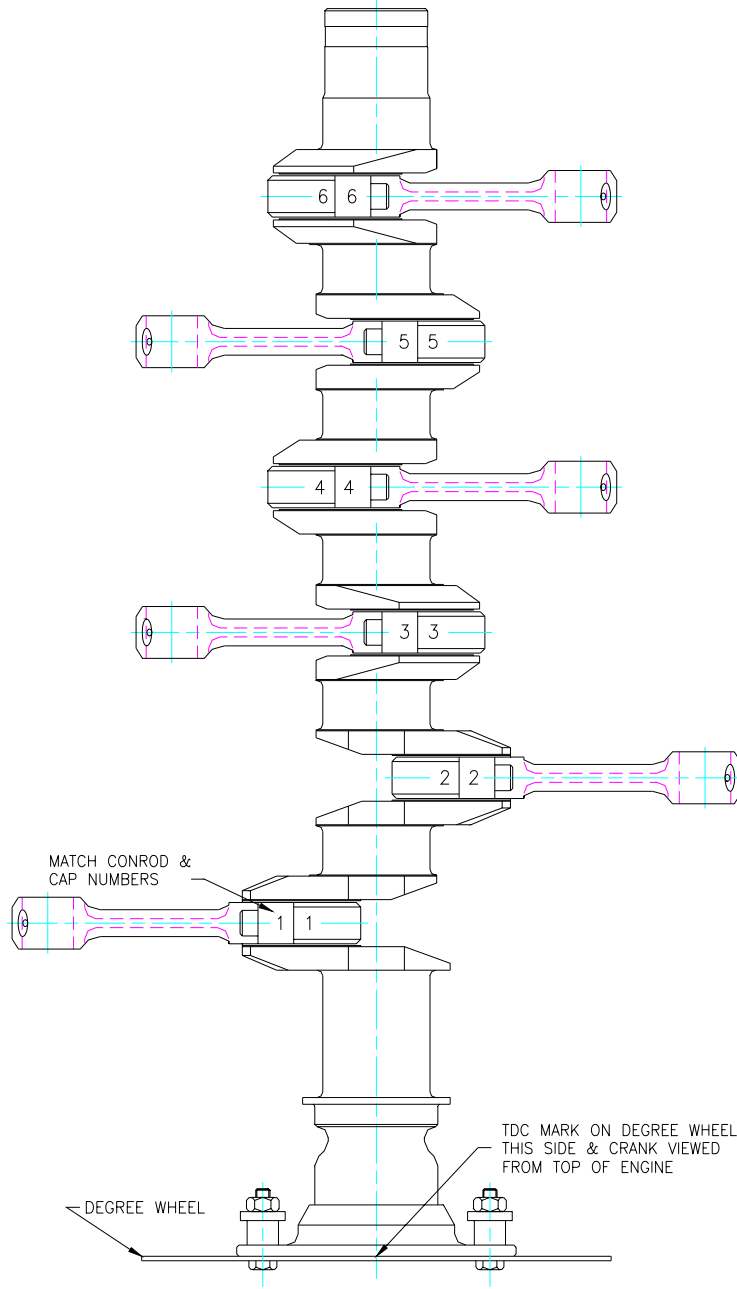

Drawing 9478083

- H2
 - c) Apply Loctite 515 to left side of the crankcase.
 - a) Fit cam shaft to left side
 - b) Inspect
 - 1) Bearing shell in position
 - 2) Loctite on all areas
 - 3) O Rings in
 - 4) Piston/Cylinder Assembly complete
 - 5) Thrust washers in position
 - 6) Dowels in
 - 7) Lifter are in with moly grease on faces
 - c) You will need
 - 1) An extra person
 - 2) 4 7/16 Ring Open End spanners
 - 3) 2 9/16 Ring Open End spanners
 - 4) 2 3/8 Plain grade 5 nuts
 - 5) 2 3/8 Belleville Washers
 - 6) 26 through stud nuts (MS21042L6)
 - 7) 10 through studs
 - 8) Torque wrench
 - 9) 7/16 x 3/8 drive 2" extension
(snap on no fres 14)
 - 10) Long Nose Pliers

Note: An extra person makes it easier to bolt up and also can cross check work.

- H3
 - a) Stage Inspection
 - b) Oil all bearing, crank and camshaft
 - c) Fit halves over crankshaft assembly and squeeze up by hand.
- H4
 - a) Using spacers and plain nuts on rear studs and belleville washers and MS21042L6 nuts on the front studs pull the crankcase together (but don't do up tight)
 - b) Remove rear nuts
- H5 Put all through studs in
- H6
 - a) Fit piston/cylinder assemblies to No. 1 & 2 conrods
 - b) Fit circlips cross check circlips for correct fit. Push cylinders home.
 - c) Put cylinder base nuts (MS21042L6) on. Using 2 7/16 ring spanners do up each side together.

If one nut goes on more than 3 turns put the 3/8 plain nut on top of it and use a 9/16 ring spanner to hold the nut, locking up the stud.

Torque up by hand lightly.

- d) Turn engine so that No. 3 & 4 conrod are out. Repeat procedure on No. 3 & 4. Repeat for conrod No. 5 & 6.
- H7
- a) Torque to 15 ft lbs then 30 ft lbs.
Note: Keep an eye on the amount of thread through each nut.
Both sides should have approx 2 turns hanging out.
 - b) Put anti sabotarge. Paint on nuts.

STAGE INSPECTION

Camshaft Timing

- H8
- a) Fit crankshaft gear as drawing and put one bolt in crankshaft to hold gear.

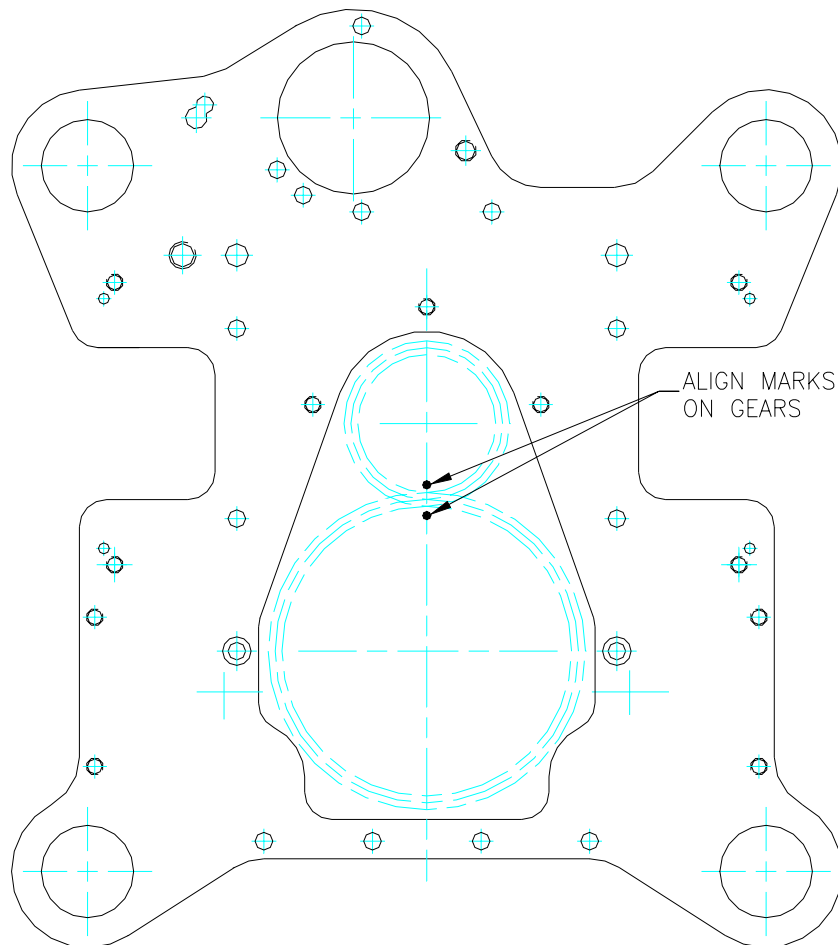

- b) Mount a dial indicator on cylinder with the plunger on the center of the piston.

- c) Zero the indicator at T.D.C.
- d) Fix a wire pointer of the oil seal bolt hole and roughly set to T.D.C.
- e) Turn 1/4 turn backwards then forward until the piston is 2mm from T.D.C. Note degrees.

Turn past T.D.C. to 2mm down from T.D.C. Note degrees.

Add two together then divide by 2 and set pointer at this (with piston down 2mm)

Note: The crank is mounted to turn the engine in direction of rotation turn crankcase anti clockwise viewed from rear.

- f) Repeat again to check.
Note: It is important to find T.D.C. accurately as it is the datum for setting the cam timing and ignition timing.
- g) Set dial indicator up to measure lift on No. 1 exhaust. Set to 0 on max lift.
- h) Turn 1/4 turn backwards then turn until 0.5mm (0.020") from peak note degrees continue turning until 0.5mm (0.020") after peak.
Note: Always turn in direction of rotation to eliminate back lash in gears.
- i) Calculate total degrees and divide by 2 to find peak. Peak should be 70°-72° after B.D.C.
- j) The cam shaft gear has 22 teeth and 6 bolt holes, so if it needs adjusting. Move the gear around and re check. Record final measurement in build sheet.

Head Fitting

- H9 a) Insure * All O Rings are place and greased
 - * Have all head bolts
 - * Head Gaskets
 - * Push rod tubes
 - * Push Rods
 - * Rocker Blocks
 - * Loctite 515
 - * Loctite 626
- b) Fit heads by hand.
- c) Push the push rod tube through the head and all the way home. Fit circlips.

Note: Make sure outside of tubes are smooth or it will damage the O Rings.

- d) Oil Push rods and fit.
Note: Make sure ball end of push rod is in the socket of the lifter. It also helps if the lifter is on the base circle of the lobe.
- e) It is a good idea to fit heads No. 3 & 4 with rocker gear before fitting rest of heads.
Put loctite 262 on rocker cap screw and torque to 8 ft lbs.
- f) Torque heads to 16 nm then 34 nm (12 ft lbs then 24 ft lbs).
- g) Adjust all valves to 0.25 mm (0.010").
Note: Valves must be adjusted with the lifter 180° to the peak lift to ensure it is on the base circle.

Sump and Induction

- H10 a) Fit sump using loctite 515 on faces and loctite 242 on threads.
Note: Because the engine mount plate goes on the sump and crankcase it is important to make sure the sump is level with the rear crank case face.
- b) Fit induction pipes to heads before fitting heads.
- c) Fit lower pipes and hoses/later engines S/N 68 on had a bolt on swept Plenum chamber.

Gear Case and Rear

- H11 a) Insure * Gear case is fitted up
* Backing plate is ready
* All bolts are ready
* Loctite 515
* Loctite 242
* Loctite 262
- b) Turn engine around until it is 25° B.T.D.C. No. 1 compression
- c) Put loctite 515 on crankcase. Fit engine mount plate. Make sure 2 inside cap screws are in. Use loctite 242 on all cap screws.
- d) Put loctite on gear case and point rotors to No: 1 position.

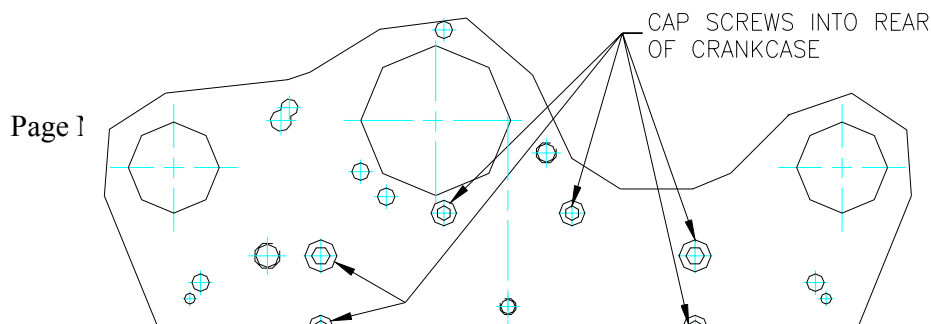

Drawing 9430064

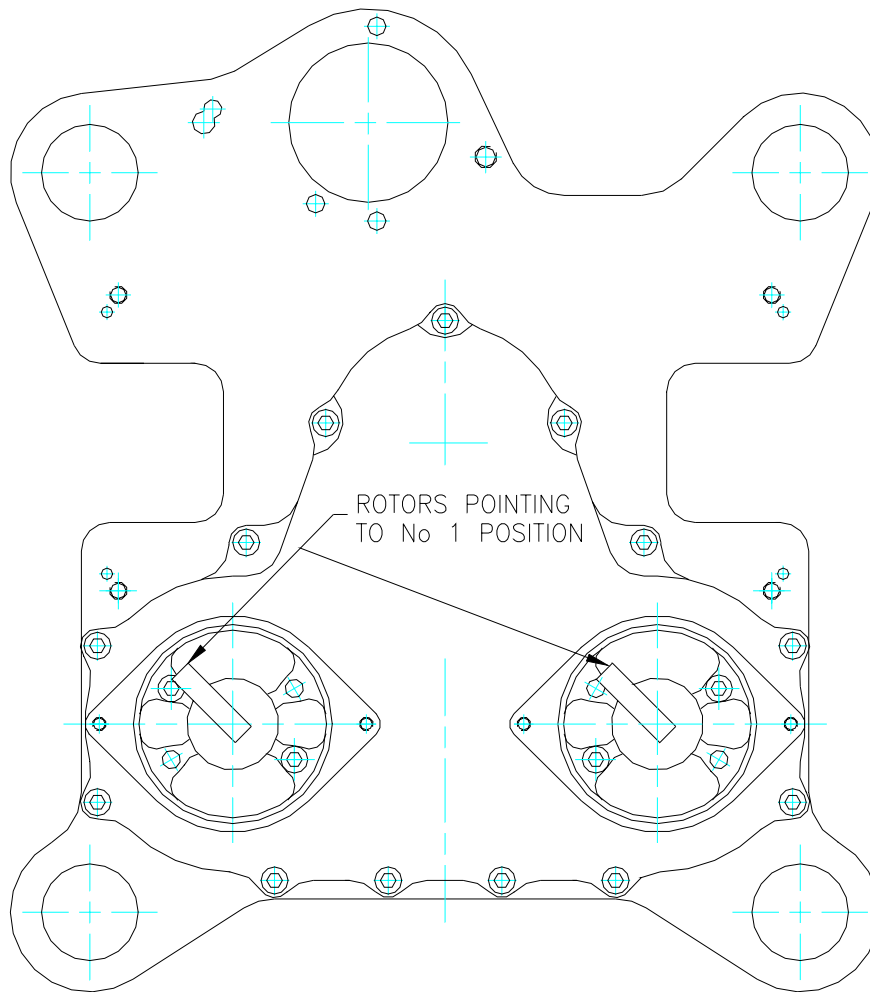

Drawing 9431064/1 REAR PLATE GEAR HOUSING & ROTORS

Drawing 9431064

Note: When gear case goes on

- 1) *Make sure No. 1 is 25° before T.D.C. compression. Both valves should be seated.*
- 2) *The rotors point to the No. 1 position on the rotor caps.*

Fit cap screws with loctite 242 and torque.

- H12 a) Fit flywheel so that magnets line up to where coils are positioned
Note: The small hole in the flywheel will line up with the hole in the crankcase. (It may not line up with the hole in the gear if it has been moved for cam timing.) Put loctite 262 on new flywheel cap screws and torque to 24 nm (18 ft lbs).
- b) Fit coil mount posts and alternator mount.
- c) Fit coils and set gap to 0.25mm (0.010")
Note: A strip of 0.25mm (0.010") card is best because it is now magnet.

H13 Fit Carburettor assembly

Note: It is very important to make sure hose clamp is at the outside end of coupling, the coupling and carby are free of oil and the carburettor goes fully into coupling.

H14 Fit Fuel Pump Assembly

Note: Use loctite 242 on cap screws. Use molybdenum disulphide grease on push rod.

Oil Pump

H15 a) Put loctite 515 on back face of oil pump backing plate and fit.

b) Fit woodruff key

c) Fit inner gear to camshaft.

d) Fit outer gear to housing and fill with oil.

e) Fit O Ring

f) Fit Oil pump on. Use loctite 242 on cap screws.

Note: When torqued up, rotate engine carefully to ensure oil pump is not binding. If oil pump binds it can shear the end of camshaft.

H16 Fit exhaust system. Use a little anti seize on cap screws and shake proof washers.

Front Seal & Flange

H17 a) Remove from vertical stand and mount on engine mount stand.

b) Remove prop flange.

c) Clean off oil from sealing surfaces.

d) Use loctite 515 on crankshaft seal carrier to crankface and loctite on cap screws. Put a little grease on seal. Install seal.

e) Prime crankshaft and new prop flange bolts with loctite primer. Using loctite 262 fit flange and torque to 40 nm (30 ft lbs).

f) Wire flange.

7.4.9 Engine Run In

The Jabiru engine is run in on a DYNOMOMETER and cooled with fan driven air. In the absence of a DYNO controlled run, engines can be run in in the airframe. Very large air ducts must be constructed to get adequate airflow for cooling in the static situation. The flying air ducts must not be used for this purpose. Extreme care must be taken with the cylinder head temps if run in is done in the airframe. Engine run in procedure allows progressive build up of the B.M.E.P. (break mean effective pressure) in the cylinders while carefully limiting the heat build up. In essence short amounts of hard work increasing in intensity while limiting the heat build up is the format. This can be seen in detail after the engine build sheets. **All engines are run in before delivery including overhauled engines as well. When delivered they are ready for flight.**

Run Procedure

- 1) Mount Engine on test rig (See engine installation)
- 2) Fill with non detergent oil.
- 3) Remove spark plugs and wind over until oil pressure is reached.
- 4) Fit plugs and cooling ducts.
- 5) Run in.
Follow run in program.
- 6) Cool down (at least 12 hours)
- 7) Retorque heads
- 8) Adjust valves
- 9) Rerun
- 10) Check leak down

Note: There is a run in program and run in checklist to fill out.

7.5 Engine Installation

<i>Operation</i>	<i>Tools</i>
1) Fit engine to engine mount	
2) Torque engine mount bolts up	7/16 Tube Socket 7/16 Ring Open End Spanner
3) Fit muffler (if not already fitted) and fit carburettor heat muff and hose.	3/16 Ball End Allen Key
4) Connect left and right ignition coils leads	
5) Connect Tacho sender	
6) Connect exhaust gas temp (if fitted)	
7) Connect cylinder head sender	18mm Spark Plug socket
8) Connect hourmeter	Screw Driver
9) Connect oil temp gauge sender	
10) Connect oil pressure gauge sender	
11) Connect starter	7/16 Ring Open End Spanner
12) Connect Battery	10mm Ring Open End Spanner
13) Connect fuel line	Screw Driver
14) Connect Oil Breather	Screw Driver
15) Connect Choke Cable	Long Nose Pliers
16) Connect Throttle Cable	Long Nose Pliers
17) Connect Air Inlet	Screw Driver
18) Fit Propeller and spinner	7/16 Ring Open End Spanner

Phillips Screw Driver

- 19) Fit Cooling Ducts 3/16 Allen Key
- 20) Prime Fuel system with electric pump and inspect for leaks
- 21) Check for oil. Fill if needed. 3.5L oil (3.69 US quarts)
- 22) Wind over to get oil pressure
- 23) Start and inspect for leaks
- 24) Test Fly
Note: First flight is a test flight so fly conservatively
- 25) Remove Cowls and inspect for anything loose, rubbing or leaking.
- 26) After 5 and 10 hours and possibly 15 hours retorque heads and adjust valves. Inspect engine installation.
- 27) After 25 hours retorque heads, adjust valves and inspect engine installation. Change oil and filter. Cut filter open and inspect. Check engine leak down.
- 28) If oil consumption is stable fill with W100 (W80 in cold conditions and W120 in very hot conditions). If it is still using oil remain on W100 oil.

7.6 Prop Strike Inspection

After ground contact of a wooden propeller, check the crankshaft flange for run-out at the front seal surface. If run-out is evident, the engine will have to be stripped and crankshaft checked for cracks.

If an engine stoppage due to force is not recorded in the logbook and not advised to Jabiru, the liability for all subsequent and consequential damage will remain with the owner. This applies to both prior to and after engine overhaul.

7.7 Build Sheets and Run In Programme

Included with the build sheets are

- * Pre Run Check List
- * Run In Programme
- * Post Run Checklist

Photocopy all documents and use photocopies to fill in. When complete, fax to Jabiru Aircraft so all documents can be kept up to date. This helps us provide a better service to our customers if we know what our engine is in and what has been done to it.

Fax Number	Within Australia	07 4155 2669
	Outside Australia	+ 61 7 4155 2669

Jabiru Aircraft Pty Ltd

WARNING

This engine has been run in and is ready for flight.

DO NOT GROUND RUN THIS ENGINE

This engine has been inhibited and the oil system drained. Before first start of new engine, remove 1 spark plug from each head. Add the required run-in oil to sump (3.4 litres), engine must have oil cooler fitted. Press starter to obtain oil pressure and to throw out excess inhibiting oil in cylinders. Replace plugs.

NOTE: ALL plastic bungs must be removed

At each 5 hours for first 15 hours check tappet clearances (0.010" cold) and cylinder head bolt torque (24 ft.lbs/32nm).

Note: New style heads have a 1/8 NPT plug to be unscrewed to uncover head bolt No. 5. After torquing reset plug with Loctite 243.

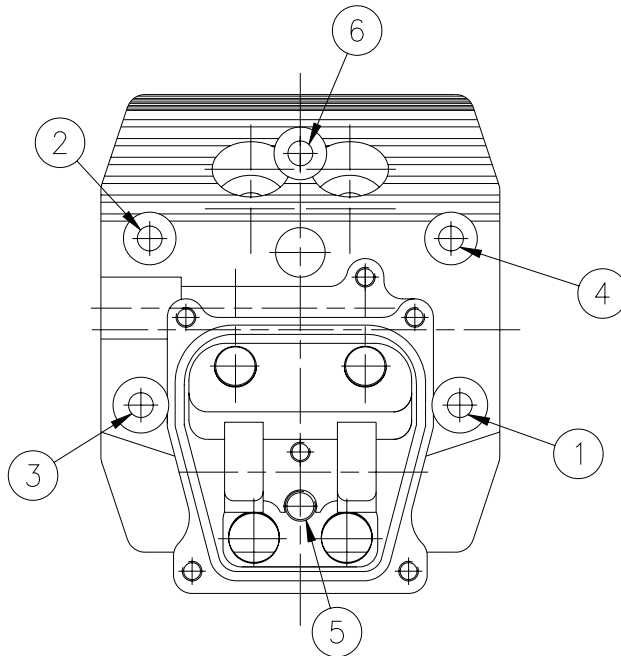

- For the first 25 hours of operation, add 3.4 litres of Shell 100 oil. After 25 hours drain oil, retorque cylinder head bolts to 24 ft lbs and check valve clearances (inlet and exhaust 0.010" cold).
- Use 3.4 litres of W100 oil for normal operation or W80 oil for cold weather operation.
- Shell also manufacture a multigrade oil Aeroshell 15W50 which is particularly suited for operations in cold climates.

UNDER NO CIRCUMSTANCES USE AUTOMOTIVE OIL IN THIS ENGINE.

Use only oils which are designed for Air Cooled Aero Engines.

- Some brands of automotive oils have been shown to cause very rapid cylinder wear. This will not be covered under warranty.
- Operate engine only on AVGAS 100LL or highest octane available MOGAS above 95 octane containing lead. Failure to do so could result in engine damage and void warranty.

***USE OF OIL/FUEL ADDITIVES VOID WARRANTY**

Jabiru 3300 – Component Assembly Procedure

Subassembly A – Crankshaft, Propeller Mount Flange and Conrods

	No.	Details	Sign	Sign	Date
	A1	Inspect for Burrs, Oil Holes, Chamfers; Clean Crankshaft, Conrods and Propeller Mount Plate			
	A2	Inspect Oil Holes and Insert Welch Plugs			
	A3	Measure Crankshaft (refer to Goods Inwards Inspection Sheet)			
	A4	Inspect and Measure Propeller Mount Flange			
	A5	Inspect and Measure Conrods (refer to Goods Inwards Inspection Sheet)			
	A6	Mount Propeller Mount Flange to crankshaft Torque to 30ft.lbs/ Lockwire			
	A7	Fit the Conrods to the Crankshaft; Use Loctite 620 on the bolts and torque to 18ft.lbs			
Stage 1	A8	Stage Inspection of Assembly – Conrods/Crankshaft			

I hereby certify that the subassembly has been completed using the approved procedures and data; and is fit for installation.

Signed: _____ Date: _____

For Jabiru Aircraft Pty Ltd
Certificate of Approval #3501

Notes: _____

Component Register and Parts Inspection Record

Subassembly A – Crankshaft, Propeller Mount Flange and Conrods

Batch _____ Serial No _____ Date _____

Description	Part No	Batch	Item	Details							
				Mains				Big End			
				1	2	3	4	1	2	3	4
Crankshaft	4629072										
Propeller Mount Flange	4662084					5	6	5	6		
Conrod	4651183			B/E Dia		7	8				
	4651183										
	4651183										
	4651183										
	4651183										
	4651183										
Conrod SHCS 5/16 x 1" UNF											
Bearings ACL	4B8290										

I hereby certify that the above listed parts conform with the dimensions, have been engraved, and installed as recorded.

Signed _____ Date _____

For Jabiru Aircraft Pty Ltd
Certificate of Approval #3501

Jabiru 3300 – Component Assembly Procedure

Subassembly B – Crankcase and Camshaft Assembly

No.	Details	Sign	Date
B1	Inspect case, deburr, clean, check oil holes		
B2	Fit inner stud “O” rings		
B3	Fit all studs		
B4	Fit outer oil suction and conrod welch plugs		
B5	Fit oil relief valve, oil pressure sender and pressure switch		
B6	Fit bearing shells (16)		
B7	Assemble and torque to 30 ft.lbs		
B8	Measure main tunnel and camshaft bearings		
B9	Measure Cam Follower Bores		
B10	Fit Lifters		
B11	Check Camshaft End Float		
B12	Check Crankshaft End Float		

I hereby certify that the subassembly has been completed using the approved procedures and data; and is fit for installation.

Signed: _____ Date: _____

For Jabiru Aircraft Pty Ltd
Certificate of Approval #3501

Notes: _____

Component Register and Parts Inspection Record

Subassembly B – Crankcase and Camshaft Assy

Batch _____ Serial No. _____ Date _____

Description	Part No	Batch	Item	Details			
Crankcase LS	4621072						
Crankcase RS	4622072			1	2	3	4 5 6 7 8
Camshaft	4625072						
Studs – Long Barrel	4291044						
Studs – Short Barrel	4292044			Cam			
Studs – Front	4293044			1	2	3	4 5 6 7
Outer Gear	4333054						
Inner Gear	4066123			Cam Followers			
Crankshaft Gear	4643084			LHS			
Main Bearings	5M1869			RHS			

I hereby certify that the above listed parts conform with the dimensions, have been engraved, and installed as recorded.

Signed _____

Date _____

For Jabiru Aircraft Pty Ltd
Certificate of Approval #3501

Jabiru 3300 – Component Assembly Procedure

Subassembly C – Pistons, Cylinders and Cylinder Heads

No.	Details	Sign	Date
C1	Clean and deburr all parts		
C2	Record all measurements		
C3	Install pushrod tube “O” Rings		
C4	Check valve seats, fit spring retainers, install valves		
C5	Fit intake pipes to heads		
C6	Complete rocker shafts and rocker assemblies		
C7	Fit cylinder base “O” rings		
C8	Fit front circlip		
C9	Check ring end gaps, fit rings to pistons		
C10	Install piston assembly to cylinder just clear of the oil ring		

I hereby certify that the subassembly has been completed using the approved procedures and data; and is fit for installation.

Signed: _____ Date: _____

For Jabiru Aircraft Pty Ltd
Certificate of Approval #3501

Notes: _____

Component Register and Parts Inspection Record

Subassembly C – Pistons, Cylinders and Cylinder Heads

Batch _____ Serial No. _____ Date _____

Description	Part No	Batch	Item	Details		
				Guides		Ring Gap
				Inlet	Outlet	
Head 1	4657082					
2	4657082					
3	4657082					
4	4657082					
5	4657082					
6	4657082					
				Bore	Length	
Cylinder 1	4554062					
2	4554062					
3	4554062					
4	4554062					
5	4554062					
6	4554062					
				Dia	Top	Bottom
Piston 1	4685083					
2	4685083					
3	4685083					
4	4685083					
5	4685083					
6	4685083					
Rockers LH	4647084					
RH	464808N					
Gudgeon Pin	4299054					

I hereby certify that the above listed parts conform with the dimensions, have been engraved, and installed as recorded.

Signed _____

Date _____

For Jabiru Aircraft Pty Ltd
Certificate of Approval #3501

Jabiru 3300 – Component Assembly Procedure

Subassembly D - Sump

No.	Details	Sign	Date
D1	Deburr and wash sump, inspect for defects		
D2	Fit oil temperature sender		

I hereby certify that the subassembly has been completed using the approved procedures and data; and is fit for installation.

Signed: _____ Date: _____

For Jabiru Aircraft Pty Ltd
Certificate of Approval #3501

Notes: _____

Component Register and Parts Inspection Record

Subassembly D – Sump

Batch _____ Serial No. _____ Date _____

Description	Part No	Batch	Item	Details
Sump	4635072			

I hereby certify that the above listed parts conform with the dimensions, have been engraved, and installed as recorded.

Signed _____ Date _____

Jabiru 3300 – Component Assembly Procedure

Subassembly E – Flywheel and Ignition Coils

No.	Details	Sign	Date
E1	Deburr and Clean		
E2	Fit magnets using silastic		
E3	Using loctite 620 fit the ring gear		
E4	Fit the alternator rotor		
E5	Fit the plugs to the ignition coils		

I hereby certify that the subassembly has been completed using the approved procedures and data; and is fit for installation.

Signed: _____ Date: _____

For Jabiru Aircraft Pty Ltd
Certificate of Approval #3501

Notes: _____

Component Register and Parts Inspection Record

Subassembly E – Flywheel Assy

Batch _____ Serial No. _____ Date _____

Description	Part No	Batch	Item	Details
Flywheel	4626173			
Ring Gear	4066423			
Coil 1	PI10522N			
2	PI10522N			

I hereby certify that the above listed parts conform with the dimensions, have been engraved, and installed as recorded.

Signed _____

Date _____

For Jabiru Aircraft Pty Ltd
Certificate of Approval #3501

Jabiru 3300 – Component Assembly Procedure

Subassembly F – Gear Case

	No.	Details	Sign	Sign	Date
	F1	Deburr, clean and inspect all of the gears			
	F2	Measure the shaft post internal diameters and the distributor shaft diameters			
	F3	Using loctite 515 fit the shaft posts to the gear housing			
	F4	Fit the distributor shaft seals and rear crankshaft seal			
	F5	Fit shafts to gears with 24 hour araldite			
	F6	Fit the distributor shafts and gears to the gear housing			
	F7	Check end clearance of distributor shaft to case flange			
Stage 2	F8	Stage Inspection of Assembly			

I hereby certify that the subassembly has been completed using the approved procedures and data; and is fit for installation.

Signed: _____ Date: _____

For Jabiru Aircraft Pty Ltd
Certificate of Approval #3501

Notes: _____

Component Register and Parts Inspection Record

Subassembly F – Gear Case

Batch _____ Serial No. _____ Date _____

Description	Part No	Batch	Item	Details
				Dia
Distributor Mount Spacer 1	4632074			
2	4632074			
Distributor Drive Shaft 1	4653184			
2	4653184			
Gear Housing	4631073			
Distributor Gear 1	4333054			
2	4333054			

I hereby certify that the above listed parts conform with the dimensions, have been engraved, and installed as recorded.

Signed _____ Date _____

For Jabiru Aircraft Pty Ltd
Certificate of Approval #3501

Jabiru 3300 – Component Assembly Procedure

Subassembly G – Fuel Pump and Carburettor

No.	Details	Sign	Date
G1	Fuel Pump – Disassembly		
G2	Drill hole in spacer and insert breather		
G3	Final assembly checked for correct flow		
G4	Drill and tap upper half for 90o elbow and fit		
G5	Clean and reassemble		
G6	Carburettor needle position		
G7	Fit fuel line		
G8	Remove bowl and check jet size		
G9	Reassembly bowl		
G10	Fuel pump and carby engraved		

I hereby certify that the subassembly has been completed using the approved procedures and data; and is fit for installation.

Signed: _____ Date: _____

For Jabiru Aircraft Pty Ltd
Certificate of Approval #3501

Notes: _____

Jabiru 3300 – Component Assembly Procedure

Subassembly H – Final Assembly

No.	Details	Sign	Sign	Date
H1	Apply Loctite 515 to crankcase halves; lubricate where necessary			
H2	Locate camshaft and crankshaft in crankcase half			
Stage 3	Stage Inspection Pre-joining Crankcase			
H3	Locate crankcase half over crankshaft and camshaft			
H4	Tension front (2) and rear (2) studs			
H5	Fit oil pump assembly and front seal housing			
H6	Place all through bolts in crankcase			
H7	Fit piston and cylinder assemblies and check circlips			
Stage 4	Stage Inspection Piston/Circlips			
H8	Tension the cylinder base studs to 25 ft.lbs then 30 ft.lbs			
H9	Fit sump			
H10	Fit heads to cylinder torque 12 ft.lbs / 24 ft.lbs			
H11	Fit push rod and valve gear. Set gap to 0.10” (0.25mm)			
H12	Check camshaft timing DEGREES			
H13	Fit fuel pump			
H14	Fit engine mount plate and gearbox housing			
H15	Fit flywheel alternator mount plate and ignition coils and lead			
H16	Fit carby assembly			
H17	Fit exhaust system			

I hereby certify that the subassembly has been completed using the approved procedures and data; and is fit for installation.

Signed: _____ Date: _____

For Jabiru Aircraft Pty Ltd
Certificate of Approval #3501

Notes: _____

JABIRU 3300 ENGINE RUN-IN SCHEDULE

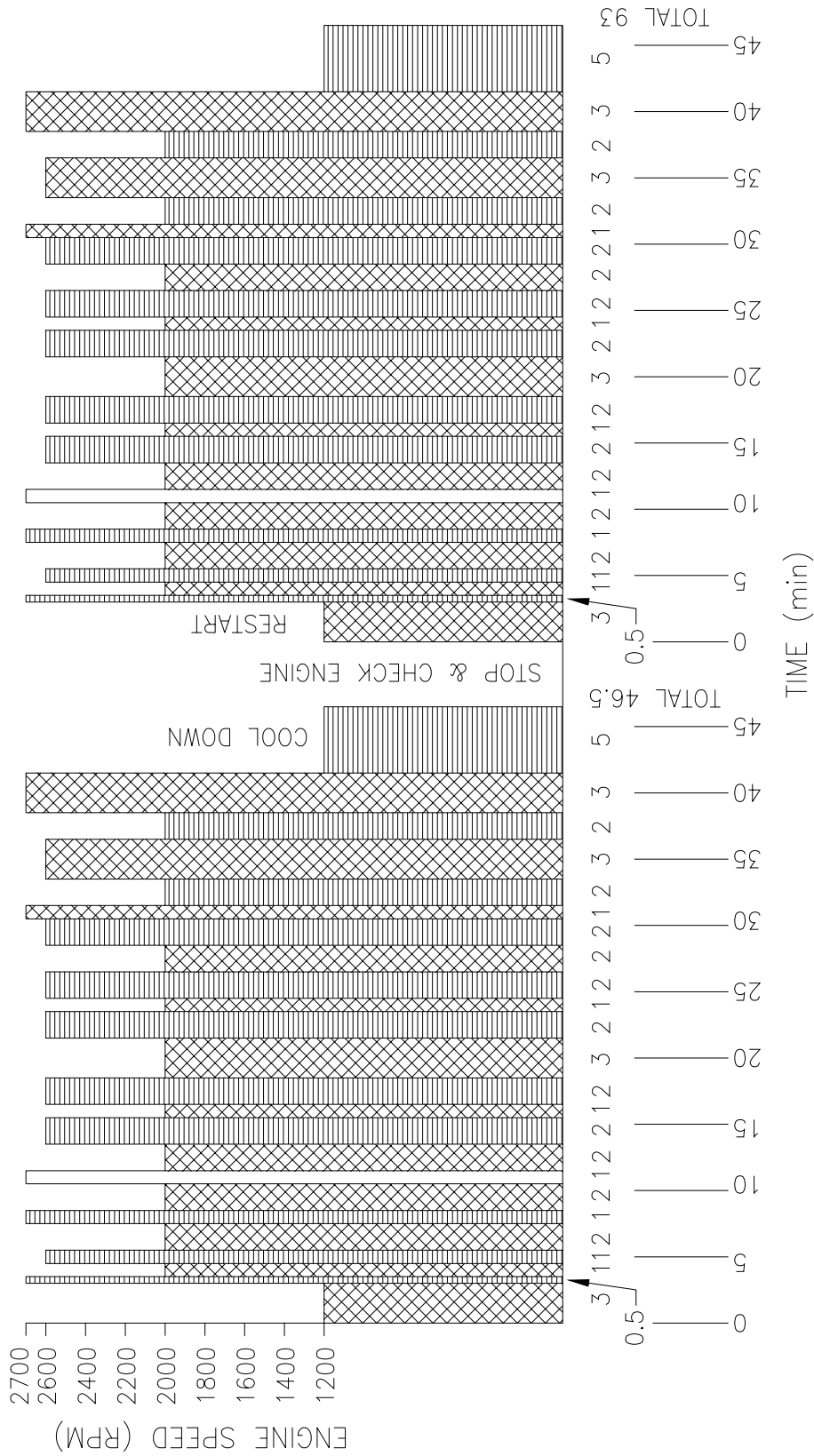

Drawing 9485093/1 3300 RUN-IN SCHEDULE

DATE:

ENGINE S/N:

SIGNATURE:

Jabiru 3300 Aero Engine Ground Test Form

Serial #

Date	Start Time	Temp	Wind	QNH	Humidity
Operator	Finish Time				
Block	Total				

Seq	Time	Duration	Condition	RPM	Rec.RPM	CHT 1	CHT 2	CHT 3	CHT 4	EGT	Oil Temp	Oil Press	Current
1		3	Start and Idle	1400									
2		30 sec / 1	Take-Off Power	Full/2000									
3		'1 / 2	75% Power	2600/2000									
4		'1 / 2	Take-Off	2700/2000									
5		15 sec / 2		2700/2000									
6		2	75% Power	2600									
7		1	Cooling Run	2000									
8		2	75% Power	2600									
9		3	Cooling Run	2000									
10			Max Cont Power										
		'2 / 1 / 2	2600/2000/2600	Mins									
		'2 / 2 / 1	2000/2600/2700	Mins									
		'2 / 3	2000/2600	Mins									
		'2 / 3	2000/2700	Mins									
11		3	Cooling Run	1200									

Record of Replenishments	
Start Fuel Quantity	
Fuel Added	
Finish Fuel Quantity	
Fuel Used During Block	
Oil Added	

Max RPM	
Low Idle RPM	
Charge Rate	

Record of Maintenance or Adjustment:

I hereby certify that this engine has been tested in accordance with the approved procedures and the Jabiru Aircraft Pty Ltd, Engines Division, Policy and Procedures Manual and is fit for use.

Signed:

Date:

Run-In Checks

1. **Preliminary**
Paperwork Complete
Sufficient Fuel
Correct Oil Level
All Connections Correct and Secure
2. **Start Run**
Start Time _____
End Time _____
3. **Ignition Checks (repeat a couple of times for each side)**
Left Side 1000/2000 rpm
Right Side 1000/2000 rpm
4. **Oil Leaks**
Check Visually
5. **Instruments**
Working and Correct Range
6. **Idle**
Check idle screw (650 Low Idle; 2700 High Idle)
7. **General Running**
Smoothness
Noises
Manifold Sealing
8. **Oil Pressure and Temp**
9. **Prop Tacho**
10. **Check alternator Charging Voltage**

Jabiru 3300 – Engine Post Run Procedure

	SIGN	DATE
1. Heads retorqued 32 Nm (24 ft/lb). Valves Adjusted.		
2. Check induction/exhaust bolts.		
3. Any changes to be made.		
4. Rerun, check for oil leaks and/or any modifications made (oil pressure/leaks etc).		
5. Check charging rate of alternator <div style="text-align: right;">Volts</div>		
6. Leak Down 80 80 80 80 80 80 Cyl 1 <input type="text"/> 2 <input type="text"/> 3 <input type="text"/> 4 <input type="text"/> 5 <input type="text"/> 6 <input type="text"/>		
7. Check all paper work		
8. Drain fuel/oil. Prepare for Shipment.		

8.0 TABLE OF LUBRICANTS

Use only oils of registered brands meeting the specification detailed at para. 2.5.

Acceptable engine lubricating oils:

Run in Period

Oil	80	100	120
Outside Air Temp	-17°C to 25°C	15°C to 35°C	Above 35°C

Normal Operations

Oil	W80	W100	W120
Outside Air Temp	-17°C to 25°C	15°C to 35°C	Above 35°C

9.0 TORQUE SPECIFICATION FOR BOLTS & NUTS

Part	Nom. Dia (mm)	Torque nm (ft.lbs)
Spark Plugs	12mm	11 (8)
Cylinder Head Bolts	5/16"	34 (24)
Crankcase Main Studs	3/8"	40 (30)
Flywheel/Gear Bolts	1/4"	20 (15)
	5/16"	24 (18)
Crankshaft Prop Flange Cap Screws (Lockwire)	3/8"	40 (30)
Oil Pump Cap Screws	5/16"	20 (15)
Tappet Cover Cap Screws	1/4"	7 (5)
Starter Motor Bolts	5/16"	20 (15)
Carburettor Flange Bolts	1/4"	11 (8)
Engine Mount Plate Bolts	1/4"	14 (10)
	5/16"	16 (12)
Gearbox Cover Bolts	1/4"	14 (10)
Alternator & Coil Mount Bolts	1/4"	14 (10)
Sump Cap Screws	1/4"	14 (10)
Conrod Bolts	5/16"	24 (18)
Propeller Bolts	1/4"	9.5 (7)
Camshaft Gear Bolts (Lockwire)	1/4"	16 (12)

9.1 PRESCRIBED SEALANTS AND PRIMERS

Item	Sealant
Main Bearing Studs	Loctite 620
Conrod Bolts	Loctite 620
Oil Pump Bolts	Loctite 243
Sump Plate Bolts	Loctite 243
Engine Mount Bolts	Loctite 243
Gearbox Cover Bolts	Loctite 243
Spark Plugs NGK D9EA*	
Spark Plug Lubricant	Loctite "Nickel Anti-Seize"
Prop Mount	Loctite 262
Flywheel	Loctite 262
Camshaft	Loctite 262

* Tighten to finger tight to seat, then with plug socket turn an additional 1/2 turn (8 ft/lbs) for a new plug.

** All gasket areas use Loctite 'Gasket Eliminator' 515

9.2 NEW TOLERANCES

(All Dimensions are in Millimetres)

<i>Crankshaft</i>	Mains Journals	47.938 to 47.918
	Big Ends Journals	44.998 to 45.000
	Thrust Face	56.95 to 57.05
<i>Crankcase</i>	Main Bearings	47.975 to 48.005
	Cam Bearings	20.00 to 20.020
	Cam Thrust Face	14.95 to 15.10
	Lifter Bores	9.000 to 9.050
	Crank Thrust	56.65 to 56.85
<i>Con Rods</i>	Big Ends	45.028 to 45.070
	Little Ends	23.005 to 23.015
	Length Between Bore Radius	74.485 to 74.498
<i>Cam Shaft</i>	Journals	19.96 to 19.97
	Valve Lift	6.900 to 7.100
	Fuel Pump Lift	2.45 to 2.55
	Thrust Faces	15.18 to 15.25
<i>Lifter</i>	Stems	8.965 to 8.990
<i>Pistons</i>	Dia	97.51 to 97.53
	Sidering Clearance	0.01 to 0.02
	Pin Dia	22.990 to 23.000
	Ring End Gap	0.400 to 1.000
<i>Cylinder Bore</i>	Dia	97.59 to 97.61
	Length over flanges	106.450 to 106.500
<i>Valve</i>	Stem Dia Inlet	6.970 to 6.990
	Stem Dia Exhaust	6.970 to 6.990
	Guide I.D. Inlet	7.040 to 7.050
	Guide I.D. Exhaust	7.040 to 7.050
	Spring Free length	39 to 42
<i>Distributor</i>	Shaft dia	14.940 to 14.970
	Shaft Post I.D.	15.00 to 15.03
	Shaft End Float	1mm

9.3 MAXIMUM ALLOWABLE CLEARANCES (Wear Limits)

(All Dimensions are in Millimetres)

Mains	0.10
Big Ends	0.10
Little Ends	0.03
Camshaft Journals	0.08
Crank End Float	0.80
Cam End Float	0.50
Lifter - Crankcase	0.12
Piston/Cylinder	0.15
Ring Side Clearance	0.05
Pin/Piston	0.04
Ring End Gap	1.20
Inlet Valve/Guide	0.12
Exhaust Valve/Guide	0.15
Min Spring Length	39.5
Distributor Shaft/Post	0.15
Distributor Shaft End Float	1.20

9.4 ELECTRICAL SYSTEMS SPECIFICATIONS

(All Dimensions are in Millimetres)

<i>Ignition</i>	Primary Resistance	8.8R to 1.0R
	Secondary Resistance	5.9kR to 7.1kR
	Coil Gap	0.27
	Plug Gap	0.55
	Ignition Harness Resistance	6.7kR per 300mm of length
<i>Alternator</i>	Coil Resistance	0.2 to 0.3 at 20°C
	Coil Earth Resistance	Infinite
	A.C. Output	40 VAC at 2750 RPM
	D.C. Output	14.2 VDA at 2750 RPM
<i>Tacho</i>	Coil Resistance	160 to 170R
	Gap	0.4

10.0 TROUBLE SHOOTING

10.1 Engine Won't Start

	Possible Cause	Remedy
1)	Ignition OFF	Switch ON
2)	Spark plug gap too large	Adjust gap to 0.6-0.7mm or renew plugs
3)	Closed fuel tap or clogged filter	Open tap, renew filter, check fuel system for leaks
4)	No fuel in tank	Refuel
5)	Wrongly connected high tension leads	Connect as shown on leads
6)	Starting Speed too low, faulty or discharged battery	Recharge or replace battery
7)	Coil to Magnet gap too wide	Adjust to 0.4mm (0.016")
8)	High tension leads loose or damaged	Check or renew connections
9)	Dampness in distributors	Thoroughly dry internally
10)	Spark plugs damp due to condensation	Thoroughly dry both inside and outside of plugs
11)	Plug face wet by fuel due to excessive actuation of choke or overflow of carb	Dry spark plugs, trace possible faults in fuel system or over flow of carb.
12)	Float valve dirty or jammed	Clean or renew float valve
13)	Jets in carb. clogged	Clean jets
14)	Water in carb.	Drain & clean carb., fuel line & filter. Water drain fuel tank
15)	Insufficient compression	Trace pressure loss & repair if necessary
16)	Engine damage	Inspect oil strainer filter & oil filter for metallic particles. If present, an engine overhaul may be necessary.

10.2 Engine Idles Unsteadily After Warm-Up Period: Smoky Exhaust Emission □

	Possible Cause	Remedy
1)	Choke activated	Close choke
2)	Float valve dirty, jammed or worn	Clean or renew float valve
3)	Intake manifold leak	Tighten all connections, renew faulty items

10.3 Engine Runs Erratically or Misfires Occasionally

	Possible Cause	Remedy
1)	Spark plug failure	Check plugs, clean inside & outside, adjust electrode gap. If necessary, renew plugs
2)	Faulty HT leads	Dry damp leads, renew damaged leads
3)	Faulty ignition unit	Renew ignition unit
4)	Clogged fuel filter	Renew fuel filter

10.4 Engine Runs Too Hot - Oil Temperature Above 110°C (230°F)

	Possible Cause	Remedy
1)	Too much oil in crankcase	Check oil level & adjust if necessary
2)	Low oil level	Check oil level & add oil if necessary
3)	Poor quality oil	Oil change, use specified oil
4)	Clogged oil filter	Change filter
5)	Excessive piston blow by	Common reason: worn or sticking piston rings, complete engine overhaul necessary
6)	Faulty bearings	If metallic particles are present in oil, complete engine overhaul necessary
7)	Faulty oil temperature gauge	Exchange gauge

10.5 Unsatisfactory Power Output

	Possible Cause	Remedy
1)	Ignition failure	Check ignition circuits; check wiring and pick-ups; replace ignition units.
2)	Too much oil in crankcase	Check oil level & adjust if necessary
3)	Insufficient fuel supply	Check fuel supply system
4)	Fuel not according to specifications	Re-fuel with specified fuel
5)	Incorrect throttle adjustment	Re-adjust throttle fitting
6)	Leak in air intake	Check and tighten all connections, check carby sockets.
7)	Carby diaphragm damage	renew diaphragm

10.6 Low Oil Pressure Possible Cause Remedy 1) Insufficient oil in sump Check oil

1)	Insufficient oil in sump	Check oil level & replenish as necessary
2)	High oil temperature	Refer to Para. 10.4
3)	Faulty pressure gauge, sender or wiring	Check gauge, sender & wiring. Renew as necessary.
4)	Faulty crankshaft bearings	Engine overhaul

10.7 Engine Keeps Running with Ignition Off

	Possible Cause	Remedy
1)	Idle speed too high	Adjust to proper idle speed (900 RPM)
2)	Faulty ignition switch	Check switch & cables. Repair/replace as necessary
3)	Overheated engine	Conduct cooling run at 900 RPM

10.8 Excessive Oil Consumption

	Possible Cause	Remedy
1)	Worn, broken or wrongly fitted piston rings	Repair/engine overhaul necessary
2)	Poor oil quality	Oil change, use specified oil
3)	Worn valve guides	Repair of cylinder head necessary
4)	Oil leaks	Seal leaks

10.9 Knocking Under Load

	Possible Cause	Remedy
1)	Octane rating of fuel too low	Use fuel with higher octane rating
2)	Spark plug fitted without sealing washer	Ensure one sealing washer on each plug
3)	Heavy carbon deposits	Remove cylinder heads & in combustion chamber remove deposits. Determine oil consumption.

10.10 Engine Hard to Start at Low Temperature

	Possible Cause	Remedy
1)	Starting speed too low	Preheat engine
2)	High oil pressure	At very low temperatures, a pressure reading of up to around 500 kpa doesn't necessarily indicate a malfunction
3)	Low battery charge	Fit fully charged battery



JABIRU AIRCRAFT PTY LTD

NEW ENGINE WARRANTY

Jabiru Aircraft Pty Ltd, hereinafter JABIRU warrants that it will make good without charge, any defect which appears in this engine.

Provided:

1. the defect has been notified in writing to JABIRU:
 - (a) before the engine has operated a total of 200 hours or,
 - (b) within twelve (12) months of the date of delivery of the engine to the first retail purchaser or from the date of independent Authority authenticated first flight.whichever comes first, and
2. the engine has been delivered to a JABIRU Approved Service Centre or such other service facility as advised by JABIRU, and
3. the engine has been installed in an aircraft type in accordance with a JABIRU approved installation system, and
4. JABIRU has determined that the defect complained of is one of workmanship and is not caused by:
 - (a) misuse or abuse of the engine such as by operation outside the approved Flight Manual, or Maintenance and Operation Manual, etc, or by neglect
 - (b) improper installation, including overheating.
 - (c) operation of the engine after it is known to be defective
 - (d) accident or deliberate act
 - (e) atmospheric fallout or flood, hail, salt, wind, etc.
 - (f) failure to carry out proper maintenance service
 - (g) use of incorrect types and/or grades of fuel, oil or lubricants
 - (h) alteration or modification of the engine by any party not authorised in writing by JABIRU
 - (i) the fitting of parts or accessories not marketed by JABIRU
 - (j) any work carried out on the engine by someone other than an Authorised JABIRU Service Centre or someone else authorised by JABIRU in writing,
 - (k) the use of any engine oil or fuel additive's or oil stabiliser's

BY JABIRU (or as otherwise decided by JABIRU) MAKING GOOD THE DEFECT BY REPAIR OR, AT THE OPTION OF JABIRU, BY REPLACEMENT.

Excluded from this Warranty are service items such as engine tuning, adjustments, replacement of air and oil filters, spark plugs, etc which are required as part of normal engine maintenance.

This Warranty is given to the person who is entitled to possession of the engine whether as owner, lessee or otherwise and is given in addition to all right conferred by law on that person.

Warranty repairs do not extend the original warranty.

Due to the substantial number of problems that can arise due to installation errors, JABIRU shall not be liable for any labour and/or service charges for removal, reinstallation and adjustment which are the responsibility of the buyer and are not covered by this Warranty. Consequential damages and freight costs are also not covered by this Warranty.

JABIRU makes no representation that this engine is suitable for installation in any particular aircraft and the responsibility for determining such suitability rests without the Buyer.

Under no condition shall JABIRU or a JABIRU Authorised Service Centre be liable for any contingent costs through the engine or aircraft being out of service for whatever reason.



SPECIAL NOTICE TO OWNERS

AVAILABILITY OF SERVICE AND PARTS AFTER WARRANTY

JABIRU Aircraft Pty Ltd maintains a substantial stock of spare parts and operates a Service Exchange Programme in respect to some components. Every endeavour is made to ensure that JABIRU carries adequate stocks of service parts and that Authorised Service Agents are equipped to provide satisfactory service, but JABIRU does not make any promise that after the expiration of the warranty such parts or service will be available, or available at any specific location or at any particular time.

UNAUTHORISED STATEMENTS IN RELATION TO JABIRU PRODUCTS

No JABIRU Authorised Service Centre or other person is authorised or permitted to give or make any statement assertion or undertaking in relation to the quality, performance, characteristics, descriptions or fitness for any purpose of any JABIRU product or in connection with the supply of any JABIRU product, which is at variance with any written statement assertion or undertaking on any of these subjects given or made by JABIRU in its published sales literature, and the company does not accept any such unauthorised action.

WARRANTY ON JABIRU REPLACEMENT PARTS

JABIRU warrants in respect of JABIRU parts and accessories required as replacement parts, that it will make good by repair or at its option by replacement any defect occurring in any such JABIRU parts and accessories within twelve (12) months from the date of acquisition. Normal wear and tear is excluded. This warranty does not cover those parts listed as exclusions in the New Engine Warranty and is subject to the same general exclusions.



JABIRU WARRANTY: CLAIM FORM

FROM: _____ **DATE:** _____

ENGINE PARTS:

AIRFRAME PARTS:

ENGINE NUMBER: _____ **AIRFRAME KIT NUMBER:** _____

PART NUMBER: _____ **TOTAL HOURS:** _____

OWNER: _____ **PREVIOUS OWNER:** _____

PART DESCRIPTION: _____

CLAIM: _____

FAULTY GOODS RETURNED: YES **COURIER Co. REF NO:** _____

NO

ALL GOODS THAT ARE BOXED AND HAVE TO PASS THROUGH CUSTOMS HAVE TO BE CLEANED AND FREE FROM CONTAMINATION WITH A STATEMENT ATTACHED SPECIFYING HOW THEY WERE CLEANED AND THAT THEY ARE FREE OF DIRT AND GRASS SEEDS. IF THEY ARE NOT CLEANED TO CUSTOMS SATISFACTION AN EXTRA CLEANING CHARGE WILL APPLY.

IF WARRANTY CLAIM IS NOT COMPLETELY AND CORRECTLY COMPLETED WARRANTY MAY BE REFUSED.

OFFICE USE ONLY	
APPROVED	
NOT APPROVED	
REASON	_____

PRINTED NAME:	_____
SIGNED: _____	DATE: _____