

**Installation Manual
Jabiru 3300 Aero Engine**

**INSTALLATION MANUAL
FOR
JABIRU 3300 AIRCRAFT ENGINE**

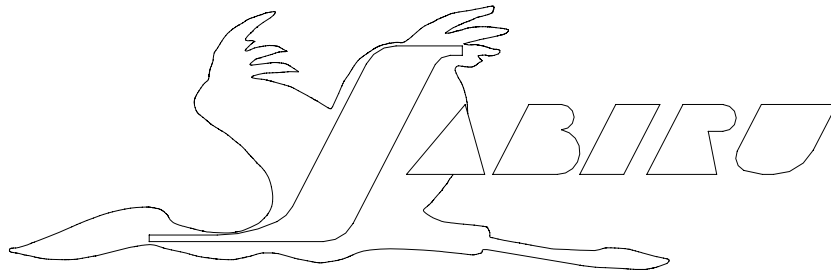

This Manual has been prepared as a guide to correctly install the Jabiru 3300 engine into an airframe.

Should you have any questions or doubts about the contents of this manual, please contact Jabiru Aircraft Pty Ltd.

REVISION	0										Dated : 09/11/00	Page: 1
-----------------	---	--	--	--	--	--	--	--	--	--	------------------	---------

**Installation Manual
Jabiru 3300 Aero Engine**

Table of Contents

1.0	<i>DESCRIPTION</i>	4
2.0	<i>SPECIFICATIONS</i>	4
3.0	<i>DIMENSIONS</i>	5
4.0	<i>DENOMINATION OF CYLINDERS</i>	5
5.0	<i>ENGINE MOUNT</i>	6
6.0	<i>CONTROLS</i>	7
6.1	Throttle and Choke	8
6.2	Master Switch, Ignition Switches and Starter Button	8
7.0	<i>INSTRUMENTS</i>	8
7.1	Electronic Tachometer	8
7.2	Oil Temperature Gauge	8
7.3	Oil Pressure Gauge	8
7.4	Cylinder Head Temperature Gauge	9
7.5	Exhaust Gas Temperature Gauge	9
8.0	<i>ELECTRICAL EQUIPMENT</i>	11
8.1	Alternator	12
8.2	Regulator	12
8.3	Ignition	12
8.4	Starter Motor	13
8.5	Battery	13
8.6	Additional Wiring Information	13
9.0	<i>FUEL SUPPLY SYSTEM</i>	14
9.1	Fuel Tank	14
9.2	Fuel Filtration	14
9.3	Mechanical Fuel Pump	14
9.4	Carburettor	14
9.5	Fuel Lines	14
10.0	<i>AIR INTAKE SYSTEM</i>	15
10.1	Air Filter	15
11.0	<i>EXHAUST SYSTEM</i>	15

REVISION	0									Dated : 09/11/00	Page: 2
-----------------	---	--	--	--	--	--	--	--	--	------------------	---------

Installation Manual Jabiru 3300 Aero Engine

12.0 COOLING SYSTEMS	15
13.0 PROPELLER SELECTION	16
14.0 AUXILIARY UNITS	16
Appendix A	17
Appendix B	18

LIST OF EFFECTIVE PAGES

The dates of issue for original & revised pages are:

Page	Issue	Date
1	1	09/03/99
2	1	09/03/99
3	1	09/03/99
4	1	09/03/99
5	1	09/03/99
6	1	09/03/99
7	1	09/03/99
8	1	09/03/99
9	1	09/03/99
10	1	09/03/99
11	1	09/03/99
12	1	09/03/99
13	1	09/03/99
14	1	09/03/99
15	1	09/03/99
16	1	09/03/99
17	1	09/03/99
18	1	09/03/99
19	1	09/03/99

REVISION	0									Dated : 09/11/00	Page: 3
-----------------	---	--	--	--	--	--	--	--	--	------------------	---------

Installation Manual

Jabiru 3300 Aero Engine

1.0 DESCRIPTION

- 4 Stroke
- 6 Cylinder Horizontally Opposed
- 1 Central Camshaft
- Push Rods
- Over Head Valves (OHV)
- Ram Air Cooled
- Wet Sump Lubrication
- Direct Propeller Drive
- Dual Transistorised Magneto Ignition
- Integrated AC Generator
- Electric Starter
- Mechanical Fuel Pump
- Naturally Aspirated – 1 Pressure Compensating Carburettor
- 8 Bearing Crankshaft

2.0 SPECIFICATIONS

- Displacement : 3314 cc
- Bore : 97.5 mm
- Stroke : 74 mm
- Compression Ratio : 7.8:1
- Direction of Rotation of Prop Shaft : Clockwise – Pilot’s view – Tractor Applications
- Ramp Weight : 81 kg (178 lbs) Complete including Exhaust, Carburettor, Starter Motor, Alternator & Ignition System.
- Ignition Timing : 25° BTDC
- Firing Order : 1 – 4 – 5 – 2 – 3 – 6
- DC Output : 15 Amps
- Fuel Consumption @ 75% Power : 20 l/hr (5 US gal/hr)
- Fuel : AVGAS 100LL and AVGAS 100/130
Leaded and Unleaded Motor Gasoline above 95 Octane Ron
- Oil : Aero Oil W Multigrade 15W-50, or equivalent Lubricant complying with MIL-L-22851C, or Lycoming Spec. 301F, or Teledyne – Continental Spec MHF-24B
- Oil Capacity : 3.5 L (3.69 US Quarts)
- Spark Plugs : NGK D9EA – Automotive

REVISION	0									Dated : 09/11/00	Page: 4
-----------------	---	--	--	--	--	--	--	--	--	------------------	---------

Installation Manual Jabiru 3300 Aero Engine

3.0 DIMENSIONS

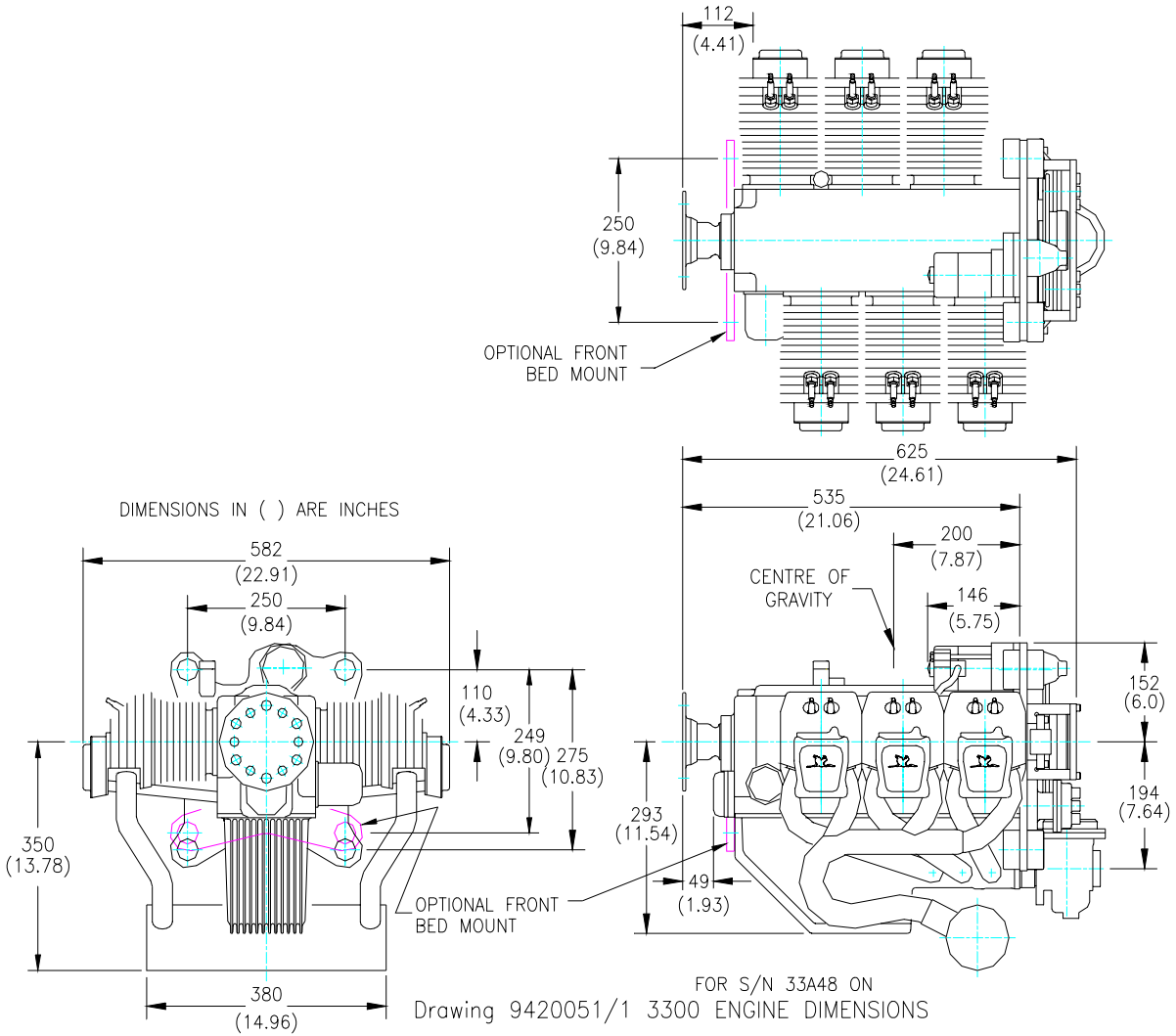

4.0 DENOMINATION OF CYLINDERS

REVISION	0		
E:\Engine Manuals\Installation Manual 3300.doc			

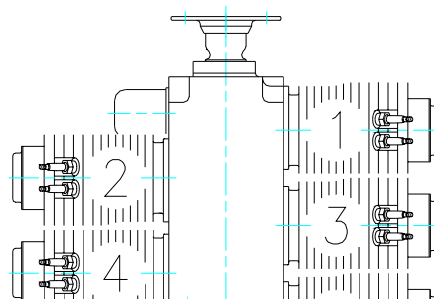

Installation Manual

Jabiru 3300 Aero Engine

Cylinder Firing Order: 1 – 4 – 5 – 2 – 3 – 6

5.0 ENGINE MOUNT

The design of the engine mount must not only take into account the structural loadings but must make allowances for accessibility of components and the removal of equipment located at the rear of the engine.

The engine has four engine mounting points located at the rear of the engine (refer to figure 1.0) from which the engine is to be mounted. An optional bed mount may be fitted.

Figure 1.0 – Engine Mount Point Locations

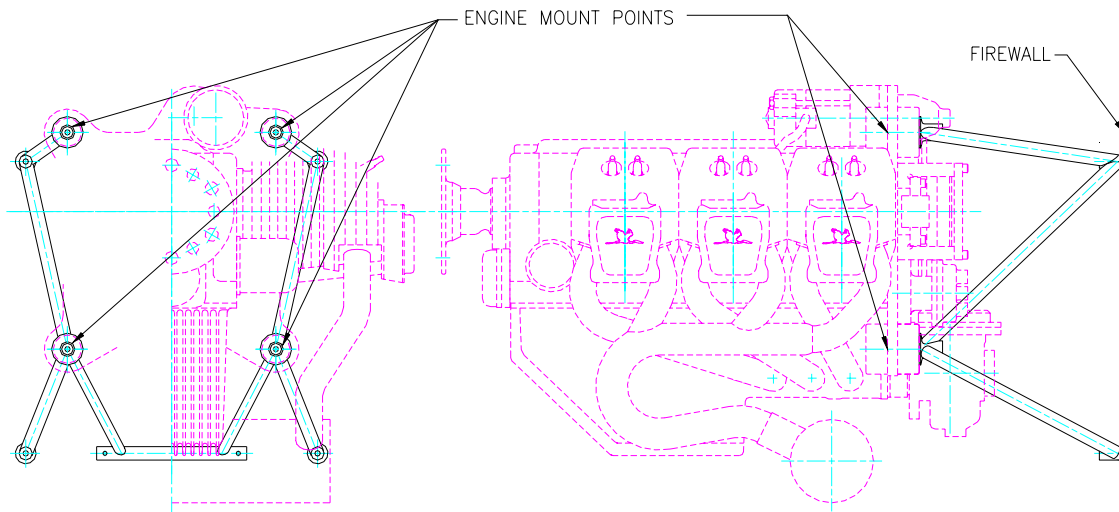

The correct installation is shown below in figure 2.0

REVISION	0									Dated : 09/11/00	Page: 6
----------	---	--	--	--	--	--	--	--	--	------------------	---------

Installation Manual

Jabiru 3300 Aero Engine

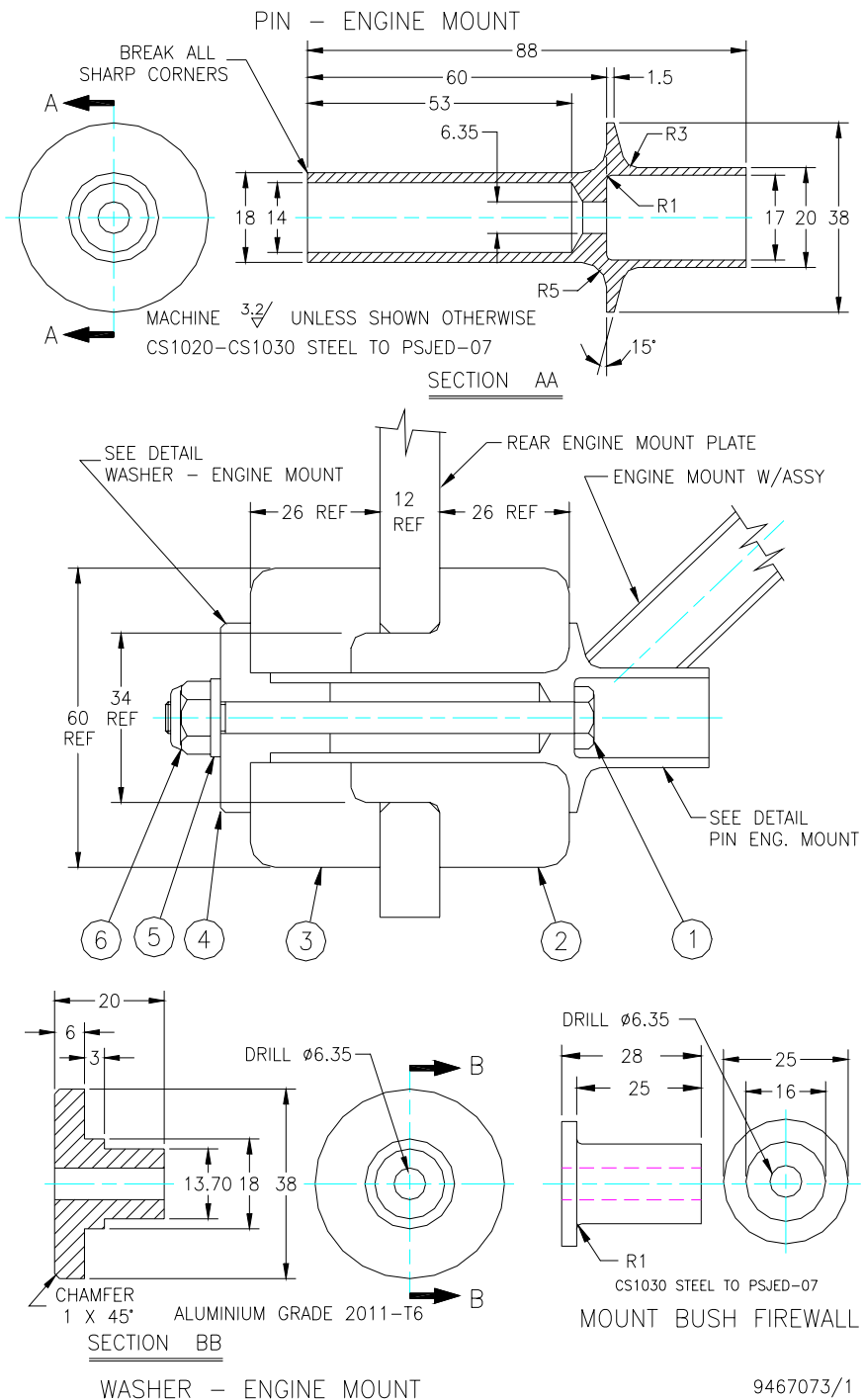

Figure 2.0 – Engine Mount Assembly

Corrections of the engine alignment may be made using spacers under the rubber cushions. The maximum spacer thickness on any one mount is 3mm.

6.0 CONTROLS

REVISION	0									Dated : 09/11/00	Page: 7
----------	---	--	--	--	--	--	--	--	--	------------------	---------

Installation Manual

Jabiru 3300 Aero Engine

This section comprises of the mechanical controls and electrical switches.

6.1 Throttle and Choke

Provisions for the connection of the throttle and choke are made on the carburettor. Note: Since a pressure compensating carburettor is used there is no mixture control.

6.2 Master Switch, Ignition Switches and Starter Button

The switches are connected as shown by the circuit diagram, on Page 10.

7.0 INSTRUMENTS

7.1 Electronic Tachometer

The tachometer uses a pick-up mounted on the alternator mounting bracket which 'counts' the teeth of the flywheel ring gear. Jabiru Part No. PI10772N is the recommended tachometer.

Tachometer Wiring

- 3 Tachometer Negative (3) to Earth
- 4 Tachometer Positive (4) to Instrument
- 8 Tachometer to Red Wire tachometer pick-up
- 7 Tachometer to Black Wire tachometer pick-up

7.2 Oil Temperature Gauge

The Oil Temperature Gauge uses an electric probe mounted in the base of the sump. Jabiru Part No. PI10752N is recommended.

Oil Temperature Wiring

- Black Oil Temperature Gauge Negative to Earth
- Red Oil Temperature Gauge Positive to Instrument
- White Oil Temperature Gauge Sensor (S) to Oil Temperature Sensor (Lower Left Eng Sump)

7.3 Oil Pressure Gauge

An electric oil pressure sender is fitted to the engine for an Oil Pressure Gauge. Jabiru Part No. PI10762N is the recommended gauge.

Oil Pressure Wiring

- Black Oil Pressure Gauge Negative to Earth
- Red Oil Pressure Gauge Positive to Instrument
- White Oil Pressure Gauge Sensor (S) to Oil Pressure Sensor (Fwd Top Eng)

REVISION	0									Dated : 09/11/00	Page: 8
----------	---	--	--	--	--	--	--	--	--	------------------	---------

Installation Manual Jabiru 3300 Aero Engine

7.4 Cylinder Head Temperature Gauge

The Cylinder Head Temperature Gauge uses a thermocouple. An audit must be done to establish the hottest cylinder and the thermocouple probe should be fitted under the exhaust spark plug on that cylinder. Jabiru Part No. PI10732N is the recommended gauge.

Cylinder Head Temperature Wiring

Loom and sensor is supplied with the instrument. These must be installed as per directions. If cable is too long it must be looped as many times as necessary and strapped behind the instrument panel.

DO NOT CUT TO LENGTH

Ensure that wire is not chaffing on the fibreglass air duct or cooling fins.
No power connection is required.

7.5 Exhaust Gas Temperature Gauge

An optional Exhaust Gas Temperature Gauge can be fitted. The probe should be positioned 100mm from the port flange on the exhaust pipe of a convenient cylinder. Jabiru Part No. PI0325N is the recommended gauge.

REVISION	0									Dated : 09/11/00	Page: 9
----------	---	--	--	--	--	--	--	--	--	------------------	---------

Installation Manual

Jabiru 3300 Aero Engine

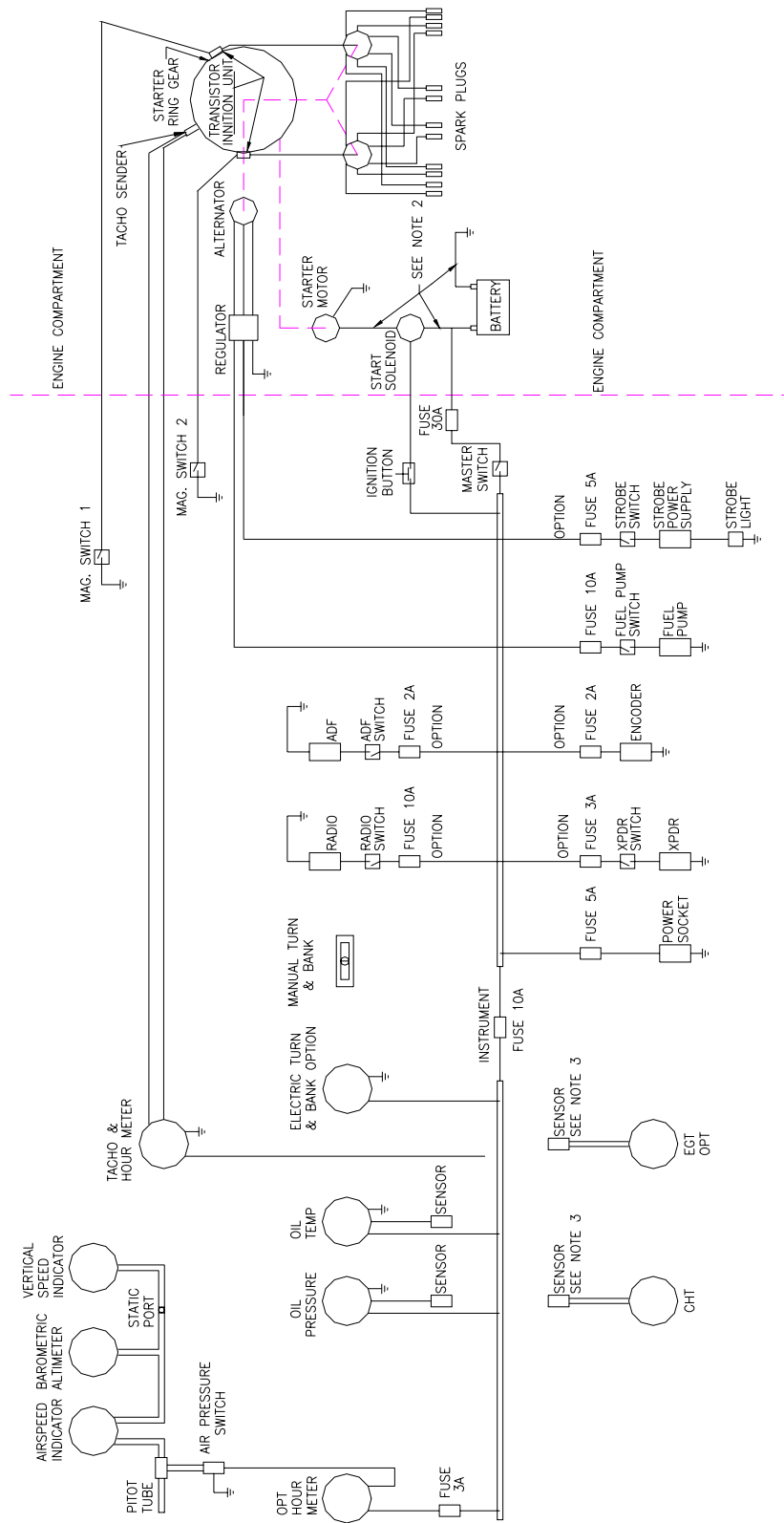

Drawing 4119234/3 ELECTRICAL WIRING 3300

REVISION	0								Dated : 09/11/00	Page: 10
-----------------	---	--	--	--	--	--	--	--	-------------------------	-----------------

WARNING

PROBLEM – Three Phase stator and regulator burning out.

WARNING – Please note brown positive wire on regulator must only carry a current when the engine is running. The brown wire must be isolated when the engine is not in use. Wiring through master switch is O.K. if the engine is started straight away. Problems will occur when engine is not started straight away e.g. someone carrying out ground testing of radios and electrical equipment. If this is carried out the brown wire will have to be isolated or the regulator and stator will burn out.

REVISION	0										Dated : 09/11/00	Page: 11
-----------------	---	--	--	--	--	--	--	--	--	--	------------------	----------

Installation Manual

Jabiru 3300 Aero Engine

8.0 ELECTRICAL EQUIPMENT

8.1 Alternator

The alternator fitted to the early Jabiru 3300 engines is a three phase, permanently excited with a regulator. The rotor is mounted on the flywheel with the stator mounted on the alternator mount plate at the back of the engine. The alternator mount plate is also the mount for the ignition coils and the vacuum pump. Later engines use a single phase alternator.

Specifications

Power (Max):200W Continuous

Note: The electrical system is Negative Earth.

8.2 Regulator

The regulator has been selected to match the voltage and current of the integral alternator. Only Jabiru Part No. PI12609N should be used. (The regulator output voltage is 14 volts \pm 0.8 volt.) Single phase alternators use regulator part no: PI10652N.

8.3 Ignition

The ignition unit has dual breakerless transistorised ignition with the magnets mounted on the flywheel and the coils mounted on the alternator mount plate.

The current from the coils flows to the distributor from where it is distributed to the spark plugs. (See also Regulator Wiring at Page 12.)

The ignition is turned off by grounding the coils via the ignition switches.

The ignition is timed to 25° BTDC

The temperature limit for the ignition coils is 100°C. This should be checked by the installer.

Transistorised Ignition 1 Wiring

- No. 1 Switch – Upper to Left Transistorised Ignition
- No. 1 Switch – Lower to Earth
- Switch Open for Ignition ON, closed for Ignition OFF.

Transistorised Ignition 2 Wiring

- No. 2 Switch – Upper to Right Transistorised Ignition

REVISION	0									Dated : 09/11/00	Page: 12
----------	---	--	--	--	--	--	--	--	--	------------------	----------

Installation Manual

Jabiru 3300 Aero Engine

No. 2 Switch – Lower to Earth
Switch Open for Ignition ON, closed for Ignition OFF.

8.4 Starter Motor

The starter is mounted on the top of the engine and drives the ring gear on the flywheel. The motor is activated by engaging the starter button (the master switch has to be ON) which trips the solenoid, hence current flows from the battery to the motor. The cable from Battery to starter should be minimum 16mm² copper.

Starter Wiring

Starter Button Switch (lower) to Main Bus
Starter Button Switch (upper) to Start Solenoid (through Grommet)

8.5 Battery

The battery should be of a light weight, 12V, 20 Ah type able to accept a charging voltage up to 14 V ($\pm 0.8V$) and a 25 AMP Input.

8.6 Additional Wiring Information

Engine Hourmeter Wiring

Red Hourmeter Positive to Positive
Black Oil Pressure Switch to Engine Sump Bolt
Black Hourmeter to Oil Pressure Switch (Fwd Eng Left)

Earth Wiring

Black Battery Earth Negative to Firewall Earth (Engine Bay)
Black Battery Earth Negative to Earth Bus

Master Wiring

Red Starter Solenoid to Main Fuse
Red Main Fuse to Master Switch (Lower)
Red Master Switch (Upper) to Main Bus
Red Main Bus to Red on Regulator

Fuel Pump Wiring

Red Main Bus to Fuel Pump Fuse
Red Fuel Pump Fuse to Fuel Pump Switch (Lower)
Red Fuel Pump Switch (Upper) to fuel Pump (Red Wire)
Black Fuel Pump (Black Wire) to Earth Bus

Regulator

Red Regulator Wire to Battery
Brown Regulator Wire to Positive (only when ignition is on)

REVISION	0									Dated : 09/11/00	Page: 13
----------	---	--	--	--	--	--	--	--	--	------------------	----------

Installation Manual

Jabiru 3300 Aero Engine

Black Regulator Wire to Earth
3 Yellow Regulator Wires to any 3 White Alternator Wires
Single Phase – 2 alternator wires to pale blue, red and yellow to positive bus and black to negative bus.

Battery Cables

Black Starter Motor Mount (Engine Rear) to Battery Negative
Red Battery Positive to Starter Solenoid
Red Starter Solenoid (Switched) to Starter Motor (Part of)

9.0 FUEL SUPPLY SYSTEM

9.1 Fuel Tank

The fuel tank must be fitted with an outlet strainer of between 8 and 16 mesh per inch, with a minimum total mesh area of 5 cm².

9.2 Fuel Filtration

A Fuel filter capable of preventing the passage of particles larger than 0.1mm (100um) must be installed between the fuel tank outlet and the fuel pump.

The filter must be present in the system for the fuel flow test. The size of the filter should give consideration to allow adequate flow with a used filter.

A Ryco Z15 or similar filter has been used successfully.

9.3 Mechanical Fuel Pump

The mechanical fuel pump is mounted on the engine crankcase and is camshaft driven. It is designed to supply fuel at the pressure described in the following paragraph.

9.4 Carburettor

A Bing constant depression type is used. This carburettor has a minimum delivery pressure of 5 kPa (0.75 Psi) and a maximum pressure of 20 kPa (3 psi). To confirm that the fuel system is capable of delivering this pressure a fuel flow test must be performed. A method for performing a fuel flow test is available from Jabiru if required. A drip deflector to deflect overflowing fuel from the exhaust system is supplied as standard equipment on the engine.

9.5 Fuel Lines

Fuel lines are nominally 6mm bore. All hoses forward of the firewall require fire resistant sheathing and those between moving sections such as between engine and firewall should be flexible.

REVISION	0									Dated : 09/11/00	Page: 14
----------	---	--	--	--	--	--	--	--	--	------------------	----------

Installation Manual

Jabiru 3300 Aero Engine

10.0 AIR INTAKE SYSTEM

10.1 Air Filter

The air filter must be of a type so as to not cause positive RAM induction pressure.

The filter must be capable of supplying 250 kg/hr (550 pph) of air

The filter may have to be changed at regular intervals if the engine is to be used in a dusty environment.

11.0 EXHAUST SYSTEM

An exhaust system is provided with the engine. Both Pusher and Tractor systems are available.

Muffler Volume – Capacity 5 litres

Back pressure at Takeoff Performance – Max 0.2 bar (2.9 psi) – readings taken 70mm from muffler flange connections.

Exhaust Gas Temperature (EGT) - Nominal 650° – 750° (1202°F – 1382°F) measured 100mm from the exhaust manifold flange.

12.0 COOLING SYSTEMS

The engine should be installed using RAMAIR ducts provided with the engine.

Cylinder and cylinder head cooling is achieved by ducting air over the cylinders. The static air pressure inside the cooling ducts must not be lower than 4.3cm (1.7”) water gauge at 1.3 times the stall speed.

An oil cooler should be installed and sized to achieve oil temperatures within the engine limits. Hoses should be nominally 8mm (5/16”) bore.

The limits in the Specification Sheet, contained in Appendix B, must be strictly adhered to. Warranty will not be paid on engine damage attributed to overheating of cylinders or oil.

The cooling ducts provided are only a starting point in establishing effective engine cooling. The ducts may require to be increased in size and additional baffles provided to achieve the specified maximum cylinder head temperature of 175°C.

REVISION	0									Dated : 09/11/00	Page: 15
----------	---	--	--	--	--	--	--	--	--	------------------	----------

Installation Manual
Jabiru 3300 Aero Engine

13.0 PROPELLER SELECTION

The hub of the propeller must be drilled with holes to match the flange. The propeller must be carefully selected to match the airframe and the engine. Propellers up to 1778mm (70") in diameter and between 762mm (30") and 1397mm (55") in pitch may be used. The propeller flange is drilled with 6 5/8" holes at 4 3/8" PCD.

Movements of inertia up to 0.3 kgm²

Applications outside this range should be referred to Jabiru.

14.0 AUXILIARY UNITS

Vacuum Pump

For the installation of an artificial horizon and/or a direction gyro a vacuum pump is necessary. A Tempest 212CW (or equivalent) vacuum pump can be fitted to the alternator mounting plate and directly coupled to the crankshaft. The drive pad is dry.

The pad and spline are SAE Standard.

REVISION	0										Dated : 09/11/00	Page: 16
-----------------	---	--	--	--	--	--	--	--	--	--	------------------	----------

Installation Manual Jabiru 3300 Aero Engine

Appendix A

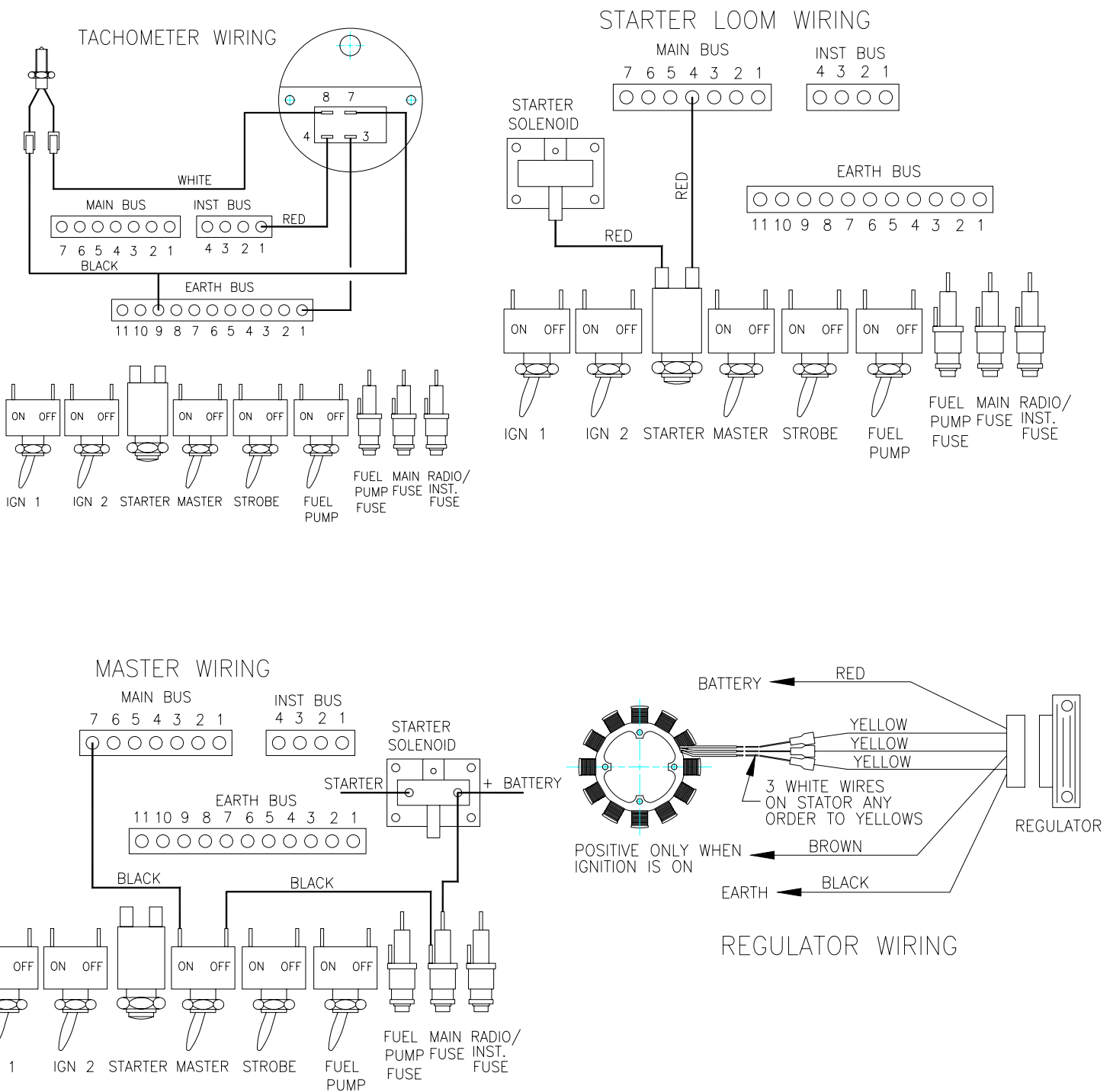

Installation Manual Jabiru 3300 Aero Engine

Appendix B

SPECIFICATION SHEET

Models: Jabiru 3300

1. MANUFACTURER

Jabiru Aircraft Pty Ltd
P.O. Box 5186
Bundaberg West
Queensland 4670

2. ENGINE PARTICULARS

- 3.1 Description** Six cylinder, horizontally opposed, four stroke engine, direct propeller drive, air cooled, wet sump, pressure lubricated, dual magneto high voltage transistorised contactless ignition, 1 x constant-pressure carburettor, electric starter, generator, mechanical fuel pump. Vacuum pump optional.
- 3.2 Displacement** 3314 cm³
- 3.3 Bore** 97.5 mm
- 3.4 Stroke** 74 mm
- 3.5 Compression Ratio** 7.8 : 1
- 3.7 Net Dry Weight** 81 kg (includes exhaust, starter, flywheel alternator)
- 3.8 Propeller Rotation Direction** Clockwise (viewed from rear)

3. ENGINE PERFORMANCE

Static sea level ratings under the following conditions:-

- International Standard Atmospheric conditions at sea level.
- Aircraft service equipment drives unloaded. (Vacuum Pump not fitted)
- Full rich fuel/air mixture.
- Maximum cylinder head temperature.
- Standard Jabiru air filter and cold air.
- Standard exhaust muffler.

REVISION	0									Dated : 09/11/00	Page: 18
----------	---	--	--	--	--	--	--	--	--	------------------	----------

Installation Manual

Jabiru 3300 Aero Engine

4.1 Engine Ratings

Maximum 120 HP / 3300 RPM ISO STD Conditions

5. OPERATING LIMITATIONS

5.1 RPM

Maximum : 3300 RPM
Recommended Cruise: 2750 RPM

5.2 Engine Cooling

Cylinder Head Temperature
Takeoff 175°C Maximum
Continuous 150°C Maximum

5.3 Fuel

5.3.1 Specifications

Avgas 100LL & Avgas 100/130
Leaded and Unleaded Motor Gasoline above 95 Octane Ron

5.3.2 Pressure to Carburettor (above ambient)

(a) Maximum 20 kPa
(b) Minimum 5 kPa

WARNING – When using auto fuels, ensure all components of the fuel delivery system are cooled to prevent fuel vaporization.

5.4 Oil

5.4.1 Specification

Aero Oil W Multigrade 15W-50,
or equivalent Lubricant complying with
MIL-L-22851C, or
Lycoming Spec. 301F, or
Teledyne - Continental Spec MHF-24B

REVISION	0									Dated : 09/11/00	Page: 18
----------	---	--	--	--	--	--	--	--	--	------------------	----------

Installation Manual

Jabiru 3300 Aero Engine

5.4.2 Inlet Temperature

Minimum for Operation	15°C
Maximum	118°C
Continuous	80°C – 100°C

5.4.3 Pressure

Normal Operations	Min	220 kPa
	Max	525 kPa
Idle	Min	80 kPa
	Max	525 kPa
Starting & Warm Up	Max	525 kPa

6. TYPES OF PROPELLER

Fixed pitch wooden propellers.
Maximum propeller diameter 1778mm (70").

7. EQUIPMENT

(a) The following equipment is included in the engine approval:-

Carburettor:	1 x Bing constant Pressure carburettor Type 94/40
Fuel Pump:	Mechanical, Jabiru part No: PG10332N
Ignition System:	Jabiru dual magneto, high voltage transistorised, contactless. Part No: PI10522N
Spark Plugs:	NGK D9EA
Alternator:	Integrated Jabiru, permanent magnet three phase alternator or single phase type.
Starter:	Jabiru 12V/1.0 kW, engagement via reduction gear and freewheel. Bosch type part no: 4776093.

(b) The following optional equipment may be driven by or fitted to the engine subject to the type number being included in the approved Jabiru Aircraft Pty Ltd engine specification:-
Vacuum Pump

REVISION	0										Dated : 09/11/00	Page: 19
-----------------	---	--	--	--	--	--	--	--	--	--	------------------	----------