

Zenith Aircraft Company

CONSTRUCTION MANUAL

Building Your Own ZODIAC CH 601 XL

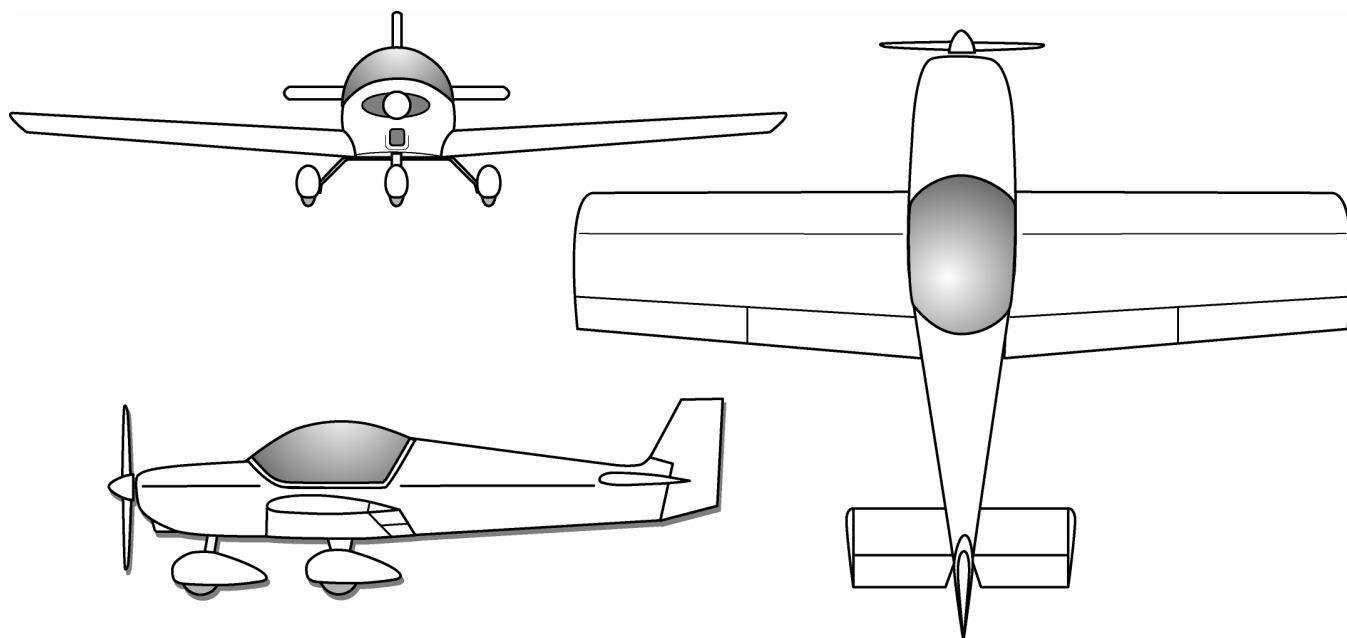

© Copyright Zenith Aircraft Company, 2003

Edition 2.0 Jan. 23, 2003

Zenith Aircraft Company
Mexico Airport, Mexico, Missouri 65265-0650 USA
www.zenithair.com

SERIAL NUMBER: 6 -

FOREWORD

Dear Builder:

Congratulations on your decision to build the ZODIAC. Here is the construction manual which, together with a complete set of drawings will help you to accomplish this wonderful feat: to build and fly your own two-seat aircraft.

The first part of the manual deals with some of the tools required for this project and the procedure with which to use them efficiently. Materials and hardware are also presented as well as tips on workmanship, corrosion protection and tolerances.

The second part is a progressive step-by-step construction guide; beginning with the rudder assembly, it describes every aspect of airframe construction.

The last part of this manual is a "weight and balance form".

The drawings and manual have been laid out to allow the average builder to understand them without having to write or call the designer or factory. They are not "perfect" or in color but supply all the information required to complete your aircraft to the design specifications. It is important to remember that the proposed building sequence has been used successfully by builders for over two decades. It would therefore be wise to use this experience and stick to the sequence. The secret of good progress is not to work like crazy in sudden short lived spurts, it lies in steady and continuous effort.

Homebuilding your aircraft is a tremendously rewarding hobby. You are the one with enough courage to do what others only dream of. Homebuilding is a useful, educational and recreational activity. While learning, you will enjoy building, then flying... and you are contributing to the progress of aviation.

IMPORTANT: Remember your family - although personally rewarding, building your own airplane is a hobby and as such should take second place to other human beings. Try not to lock yourself in your workshop too often as other people need your presence, too.

Your ultimate aim is always 'flying', but problems arise with trying to sprint through construction ... take your time, proceed at a comfortable and steady pace ... always be sure you understand the drawings and instructions. Polishing parts while building is a natural tendency but not necessary and it takes a lot of time. Experience has shown over and over again that after the builder has overcome his or her natural fear of making mistakes, construction really progresses well. Beware only that overconfidence does not set in: to avoid frustrating mistakes follow the drawings and manual ... Soon you will be proud, and with reasons, of the accomplished work.

In this easy-to-follow and straight-forward manual, it has not always been possible or considered essential to expand on all details of designing background, construction methods, etc .. Rely on your common sense to ensure that all the necessary parts are installed before the structure is permanently riveted closed !!

To avoid such incidents, the builder must think things through and understand all the information set out in the manual before drilling and riveting.

WARNING: It is the builder's responsibility to assure himself / herself that all components of the aircraft are made to the required specifications and standards. This applies to any and all parts, both raw material and kit parts. As we have no control of the builder's ability to construct and fly the aircraft, we do not take responsibility and give no warranty, implied or expressed whatsoever, regarding structural integrity, performance, flight characteristics or safety of the builder's completed aircraft.

GENERAL INFORMATION

NEWSLETTER

The official newsletter is published by ZENAIR NEWS, 1002 Heather Lane, Hartford, WI 53027-9045
Tel: 262-966-7627 Email: sskrog@aol.com

It contains updates, flight reports, builder's experiences and other useful information. Subscribe and make sure you stay informed through the designer's regular columns. While you will find much information through the Zenith website (www.zenithair.com), the newsletter is the official way to be informed of updates. Builders are also encouraged to register online at <http://www.zenithair.com/bldr.htm> to gain access to exclusive online builder resources.

MODIFICATIONS

To assure structural integrity, builders are urged to obtain prior approval from the designer or factory for any modification they wish to incorporate in their aircraft.

Write to: ZENAIR Ltd., P.O. Box 235 Midland ON L4R 4K8, Canada.

Explain your modification or problem, outline your solution with sketches ... and leave space for the answer. The overall effect of the modification will be checked and each modification will be approved individually. You will receive an opinion (i.e. "good", "heavy", "alters performance", "effects your stability", etc ...).

NOTE: For substantial modifications a 'redesign fee' may be required.

Technical Support and Correspondence:

In all correspondence supply: your Serial number (see front cover) and your complete name and address.

Zenith Aircraft Company

Mailing Address: P.O. Box 650, Mexico, MO 65265-0650 USA
Physical Address: Mexico Airport, Mexico, MO 65265 USA
Telephone: 573-581-9000 – Monday - Friday, 8:00 AM - 5:00 PM Central
Fax: 573-581-0011
Internet: E-mail: info@zenithair.com
World Wide Web: <http://www.zenithair.com>

Change of mailing address: Please notify Zenith Aircraft Company and ZENAIR NEWS so that all correspondence will reach you without delay.

SOURCES OF REFERENCE

A good reference booklet is: 'Standard Aircraft Handbook,' by L. Reithaier (Aero publishing Inc)
This book can be purchased online at www.amazon.com

We also recommend: AC 43.13-1B/2B Acceptable methods Techniques, and Repair FAA, U.S. Government Printing Office; Washington, DC 20402

Join a local EAA (Experimental Aircraft Association) chapter, where you will meet other people building their own aircraft: They will help you if required and give you the up to date information on how to proceed with the official mandatory inspections and the paperwork necessary for FAA registration. Participate in the EAA's Technical Advisor and Flight Advisor Programs.

To join EAA and a local chapter, contact:

EAA headquarters, PO Box 3086, Oshkosh, WI. USA 54903-3086

Tel: 920-426-4800 **www.eaa.org**

FAA Amateur Build Aircraft Reference Material

AC 20-27D, Certification and Operation of Amateur-Built Aircraft

<http://av-info.faa.gov/dst/amateur/>

The FAA also publishes a number of useful publications on flight testing, maintenance and operation of experimental amateur-built aircraft. The Guide to Federal Aviation Administration Publication (FAA-APA-PG-13) is also available from:

US DOT
Publication Section 442.32
Washington DC, 20590

NOTE: The drawings are not to scale on purpose. This will avoid the temptation you may have to measure the drawing, or check the parts against them. This could lead to inconsistencies as paper shrinks and expands with humidity and size variations occur with printing.

Also: The number of rivets is given in digits (so is the pitch – the spacing between holes); do not attempt to count the dots from the drawings!

Photos: Some pictures of the different assemblies may not correspond with the drawings. The drawings always come first.

WORKING TOLERANCES:

Follow the dimensions indicated in the drawings as closely as possible. You are building a well designed light aircraft and not a jet airliner. Use common sense (for example it is easier to remake a spar which is 1/8" (3mm) too narrow than to start altering all the ribs and other parts which have to fit to the spar; besides the structural integrity, the flying characteristics and the performances may be adversely affected ...)

Try to achieve an accuracy of: 1/64" (.5mm) on spar and rib heights,
 1/16" (1.5mm) on all other parts
 1/8" (3mm) on the various assemblies and rivet spacing.

For drilled holes, the applicable tolerances are automatically provided when using the tools correctly. There are only a very few close tolerances to be respected. They are only common sense and shown on the drawings. Do not let yourself be discouraged with anyone else's differing opinion, or by reading too much ...

Scratches: a) Spars and longerons: All transverse scratches and nicks must be removed by filing and sanding lengthwise.

b) All other parts: Unless deep, scratches will not reduce the fatigue-life of the structure

Especially IMPORTANT: Any scratch and/or nick must be removed from the spars and fuselage longerons by filing and sanding LENGTHWISE.

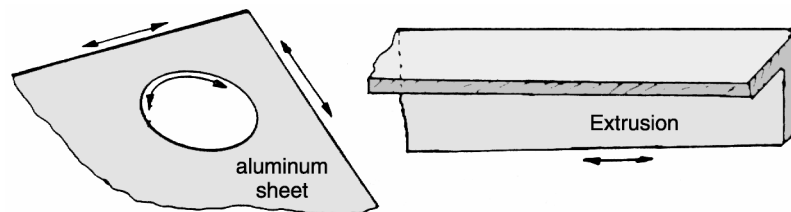

EDGE DISTANCE: The distance of a hole from the material edge should be three times the rivet diameter. The absolute minimum acceptable is 2 x hole/rivet diameter.

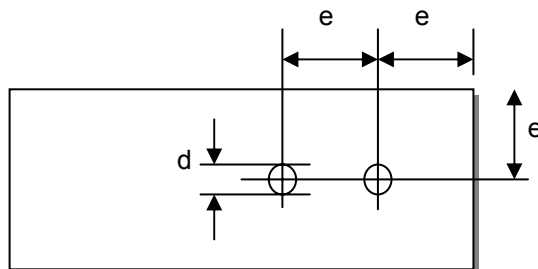

**e (edge distance) =
approx. 3 X d
(hole diameter)**

After drilling, the parts are temporarily held in position with 'clecos'. Use the clecos as you drill an assembly together. When everything fits, disassemble, deburr the holes, apply corrosion protection, reassemble and rivet.

WELDING: Unless you are a pro, have the welded parts welded professionally. Electric or gas welding for 4130 N and steel, heliarc for the aluminum Fuel tanks.

HEAT TREATMENT: Heat treatment is not a homebuilder's technique. The Zenair has been designed so that no heat treatment is required.

CRACKED PARTS: Replace every part which reveals cracks after manufacturing. Cracks may occur when bending with too small a radius ($R > 3xt$), forgetting to sand the edges smooth, mishandling (tool or other marks...).

Metric sheet metal thickness equivalence:

Inches t=	.016"	.025"	.032"	.040"	.080"	.09"	.125"
mm. t=	0.40	0.60	0.80	1.00	2.00	2.5	3.0

Inches and millimeters: 1 inch = 25.4 mm.

1 ft = 12" = 305mm

BUILDING FROM FLAT MATERIAL VERSUS KIT

The drawings and the manual allow you to build 'from scratch'. But if you only have little time and/or no access to some special equipment to make the primary parts, a kit is the answer.

Document your Aircraft Construction:

- Keep a detailed building log, including photos
- Keep all receipts and shipping documents

Take photographs of sub-assemblies (before final covering). This will also be a commemorative diary of your project, and may be useful if you ever want to resell your aircraft!

MATERIALS

The drawings only specify the alloy thickness in thousands of an inch underneath the description of the part number i.e. t=.025" refers to the material thickness for the following alloy specifications:

Aluminum Alloys: 6061-T6 QQA 250/11 High strength corrosion resistant aluminum-silicon alloy.
or
2024-T3 (or T4) QQA 250/4 High strength alum.-copper alloy, corrosion resistance is provided by the cladding and/or zinc chromate primer.
IMPORTANT: Do not use 6061-T4 or 7075 in this aircraft.

NOTE: We do NOT recommend 2024-T3 for the formed parts (ribs) - use 6061-T6.

Aluminum extrusions: 6061-T6 or 6351-T6 (or 2024-T3)
Angles: 1 ½ x 1 x 1/8 (40x25x3 mm.)
¾ x ¾ x .093 (20x20x2.5 mm.)
DO NOT USE 6061-T4 or 6351-T4

Aluminum Tubing: 6061-T6 or 6351-T6 (or 2024-T3)
DO NOT use 6061-T4, nor 6351-T4.

Steel: Use 4130-N (normalized chrome-moly) when specified on the drawings. After welding, let cool down in calm air (not a draft). Use any plain carbon 'mild steel', when 'steel' only is specified.

Firewall: Galvanized low carbon steel t=.020 to .025 (gauge 24 to 26).

Grain direction: Except for the wing spar cap doublers noted on the drawing by ←→ (see 6V2-7 & 8 and 6V4-6) and landing gear forks (6L1-3) the aircraft is designed so that you do not have to worry about sheet metal grain direction (in spite of what you may read or what 'well informed people' may tell you).

MATERIALS LIST: As most all builders are building from a kit, there is no material list available. If you need one, it is best to make up your own by going through the drawings.

AIRFRAME BOLTS – GENERAL

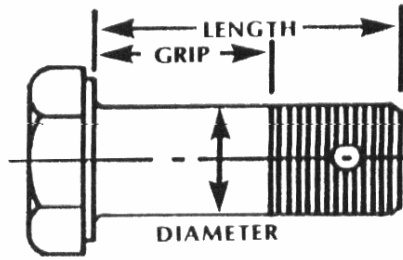

Bolt shown with drilled shank

AN Bolt designation: **AN – X – H – Y – A**

X = diameter: X/16 inch.

H = Dilled head (for safety wire)

Y = Length by increment of 1/8 inch

A = without any hole (if A is omitted: castle nut and pin).

Machine screws: AN 525-10-32: same diam. and nuts as AN-3 bolt.
AN 525-8-32 Diam .102" (drill #20) with SL nut AN 365-8-32, washer AN960-8

BOLT GRIP LENGTH: Refer to the table published in the Standard Aircraft Handbook. No thread in the parts, and two threads visible above the tightened SL nut.

- Minimum: no washer under the head.
One washer under the nut.
- Maximum: one washer under the head
Two washers under nut.

DRILL		BOLTS			NUTS		WASHERS	
INCH	mm.	AN#	THREAD	DIAM.	CASTLE NUT	SELF LOCKING (SL)	AN#	THICK.
3/16	4.8	AN-3	10-32	.189"	AN 320-3	AN-365-3-10-32	AN960-10	.053"
1/4	6.4	AN-4	1/4 - 28	.249"	AN 320-4	AN-365-4-428	AN960-416	.063"
5/16	8.0	AN-5	5/16 - 24	.312"	AN 320-5	AN-365-5-524	AN960-516	.063"
3/8	9.6	AN-6	3/8 - 24	.374"	AN 320-6	AN-365-6-624	AN960-616	.063"

Bolt torque: Table for AN 365 nuts on AN-3 to -8 bolts, dry (not oiled) threads – refer to Chapter 7 section 3 of AC43.13-1B

SOLID RIVETS:

The quantity and sizes of the solid rivets have been kept to a minimum. They are only used on highly stressed parts.

Before riveting: Apply the corrosion protection if applicable on both surfaces (let dry), 'cleco' the parts together, insert the rivets and set them.

Solid rivet designation: Example: **AN - 470 - AD - 5 - 6**

AN = Standards Army and Navy (or MS-20-Military Standard).

470 = Type of head: 470 = Universal round head (426 = 100-degree countersunk head).

AD or A: AD = 2117 Aluminum alloy (shear strength is 26,000 psi, the head has a small dimple in the center. A = 1100 Aluminum alloy (soft rivets for trailing edges only).

5 = Diameter in inch/32

6 = Length in inch/16, determined by grip

All AD and only AD rivets have a small dimple in the center of the original rivet head.

BLIND RIVETS:

The blind rivets are set with a standard hand riveter, with customized heads (nose piece) - it is easy, fast and quiet. They are used with access from one side only (no dolly or bucking bar is needed). On the drawings; they are designated A4 and A5 and need a shear strength of 110 and 180 lbs respectively. The recommended rivets A4 and A5 (and supplied in the kit) are the Avdel "Avex". They have a shear strength of 130 and 220 lbs respectively (stem removed). These aluminum rivets are corrosion resistant, they are multi-grip (you do not need many lengths for each diameter), and the stem is locked in (does not fall out).

The flush countersunk Avex rivet type A4 and A5 supplied in the kit need a specially ground head piece on the puller to get a low, protruding rounded head:

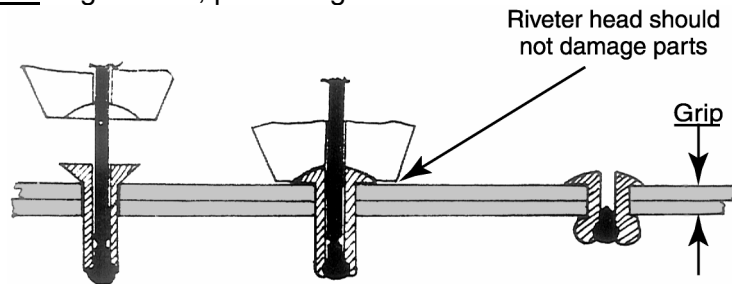

<u>Zenair Denomination</u>	<u>Avdel Avex Ref.</u>	<u>Grip range</u>
A4	1604-0412	0 to 1/4" (0 to 6mm)
A5	1604-0514	0 to 5/16 (0 to 8mm)

To modify the riveter head: The objective is to bring the outer edge of the rivet down on the skin, the most effective is when the machined diameter of the nose piece is equal to the diameter of the rivet head. This will require two difference size riveter heads, one for the A4 and another for the A5.

The machine depth is the distance from the sheet to the outer edge of the rivet, check the depth by pulling some rivets: if the nose piece marks and leaves a ring on the sheet then it is too deep; simply file the nose piece down. If there is a gap between the edge of the rivet head and the sheet then the nose piece is not deep enough.

Expect the standard (flat) riveter head (nose piece) to have been tempered by the manufacture. Before it can be machined, de-temper (soften it) by heating it up with a blow torch until it glows. Let it cool off and proceed to machine the head. With aluminum rivets, it is not necessary to do any additional heat treatment to the nose piece.

One suggestion is to machine with a solid carbide burr "shape E" oval 1/2"x 7/8" double cut model E-141D part number 20-022-213 available from Travers Tool Co. Tel 1-800-221-0270

An another option is to send us your riveter heads to be machined.

Domed head rivets: the A3 (small 3/32"), the A6 (large 3/16" diameter) and the stainless steel AS5 are generally supplied with a domed head. Rivets with a domed head do not need the special "cupped" nose piece - it is only required to convert the flush countersunk rivets of type A4 and A5 into a domed head. For domed head rivets use a flat nose piece on the riveter, this is the standard nose piece that comes with most riveters.

Pneumatic Riveter.

A small air compressor will work fine to operate a pneumatic riveter, most tools are rated at 80PSI and 4.2CFM air consumption. If necessary install an air regulator if the riveter pulls too aggressively!

DRILL BITS / RIVET PITCH

NUMBER DRILL BITS (HOLE DIAMETER)

	#30 (0.1285")	#20 (0.1610")	3/16" (0.1875")	1/4"	5/16"	3/8"
mm	3.2	4.0	4.8	6.4	8.0	9.6
BLIND RIVETS (AVEX)	A4	A5				
BOLTS (AN)			AN-3	AN-4	AN-5	AN-6
SCREWS (AN-525)		8-32	(10-32)			
SOLID RIVETS (AN-470)	AD-4	AD-5	(AD-6)			

Holes that may be slightly oversized will be filled in by the blind rivet as it expands. This is not the case with bolts.

- Use the correct drill size as per table above.
- Mark the rivet line (felt marker or pencil, never a scribe or center punch). On the rib flanges use a marking gauge as shown in the tool section.
- Lay out the rivet pitch (spacing between holes) shown on the drawings. The drawings provide either the rivet pitch, or the number of rivets.

NEVER COUNT THE + OR X MARKINGS ON THE DRAWINGS

DRILLING OUT RIVETS: - Use the same size drill bit as the original hole (#30 for A4)

- Carefully drill off the rivet head (remove rivet head from drill bit).
- Turn the drill by hand (or apply short power bursts on the trigger) to push the remainder of the rivet out.
- Check that the drill bit does not make contact with the steel mandrel in the rivet, this could cause the drill bit to slide and elongate the hole.

FLUSH TACK RIVETS: The few tack rivets are counter-bored with a 1/4" drill bit. Be very careful on the sheet metal not to oversize hole! Use to temporarily hold the wing skins to the spar to keep the wing square as it is turned over to close the leading edge. Plan ahead to avoid placing the tack rivets where they will interfere with the rivet line through the nose skin. The suggested location is 20mm outboard of the intersection of the rivet line through the center line of the rib flange with the rivet line through the main spar (4 to 5 tack rivets per wing is sufficient). Use an A4 with a flat nose piece on the riveter head to set the 4 to 5 rivets.

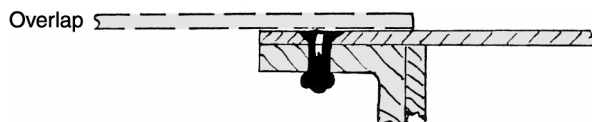

NOTE: When there is a choice, the original rivet head should be on the side of the thinnest part, or the outside of the aircraft.

STANDARD RIVET PITCH: Although in this new edition the rivet pitch (spacing) has been indicated on the drawings, if you cannot find it, use 40 mm.

WORKING WITH SHEET METAL / TOOLS

Marking gauge:

Use soft tip marker. NEVER USE A SCRIBER! Berol China marker (grease pencil), or Col-erase Pencil (color pencils) can also be used.

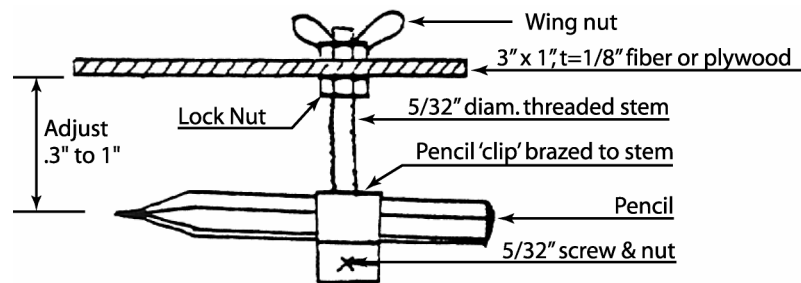

HAND SNIPS: Aviation snips: right = read handle, left = green handle. When using the hand snips remember there is the easy way by holding the snips at a slight angle (try it out on some scrap sheet metal) . Avoid marking the sheet with the snip tip by only cutting on 1/2 to 3/4 of the length of the snip blade and not closing the snips completely. Most snips have serrated teeth along the edge of the cutting blade, depending on how new they are these can cause the edge of the skin to be a little rough. After cutting, dress up the edge by filing the edge smooth. When done, you should be able to run your finger over the edge without picking up any splinters.

CUTTING: ALUMINUM EXTRUSIONS, AND STEEL PARTS: Use a hack saw (24 teeth per inch) or band saw. Always finish (remove the saw marks) with a file and Emory cloth for a smooth edge.

DRILLING: Compact electric drill (Approx. 2000 RPM) fitted with a rubber washer on the drill bit shank (prevents damages to the metal).

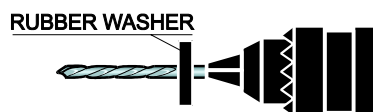

DE-BURRING: Using a drill bit to deburr thin material has tendency to countersink the whole, on the other hand, deburring with the flat side of a file can have a tendency to draw the edges of the hole towards the middle: however, when using number drill the hole will be drill oversize so it will not be necessary to force the rivets in the holes.

In general a sheared edge does not have to be file smooth, it is unusual for a drilled hole to leave fracture marks around the hole. The purpose of deburring is to assure contact between the parts: to remove burrs that have accumulated between the parts.

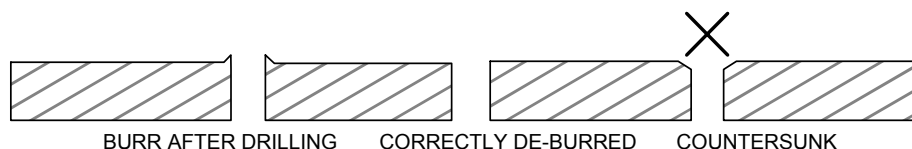

BENDING: It is important to remember that the bending radius must be at least three times the material thickness: $R = 3t$ (see tool section). If the radius is smaller the aircraft aluminum will start cracking. Also refer to additional tips given in the tool section.

BENDING BRAKE: A must for the scratch builder, drawings are available from Zenith Aircraft Co. for the "Zenair" 4 ft. homebuilt bending brake: highly recommended for bending the many shorter parts.

All the parts for your ZODIAC under .063 are bent with $R=1/8"=3\text{mm}$. Instead of using the complicated bend line method; following approximation provides excellent results:

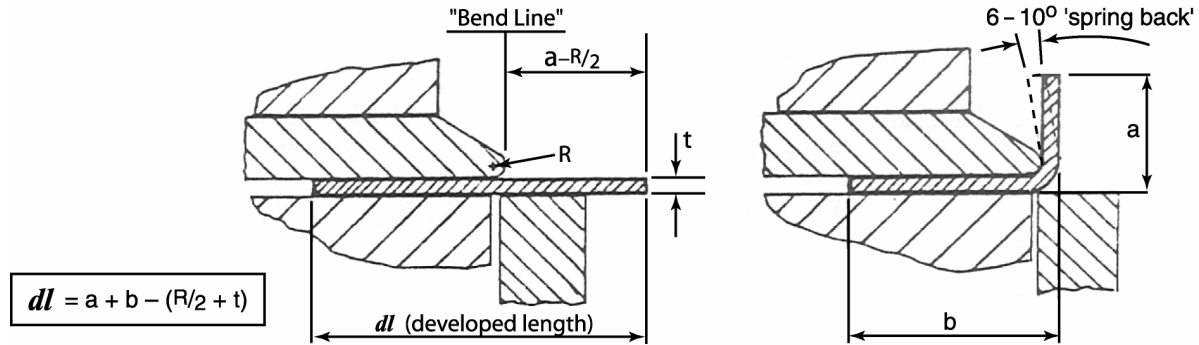

- A drill press is almost a must when flycutting with the flycutter.
- When using solid rivets: a compressor, the rivet gun (Chicago Pneumatic CP X 2), the rivet snaps and bucking bars are mandatory.
- A band saw, although not mandatory, is very handy (12 teeth/inch blade)

Other Useful sheet metal tools:

- "Flat" pliers, or bending pliers, or hand seamer:

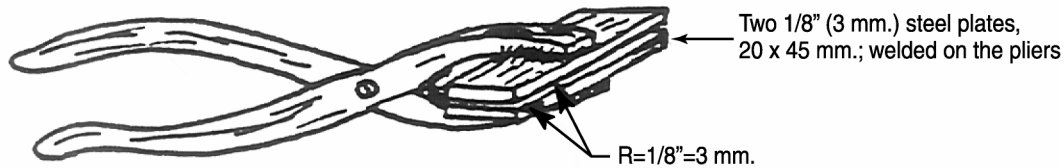

For short folds/bends, you may use the 'hand' method of bending:

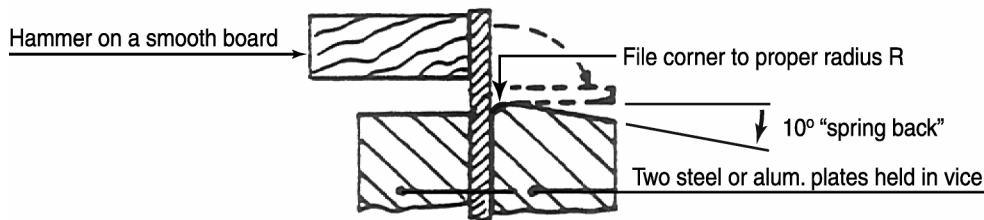

Crimping tool for "corrugating" the flanges:

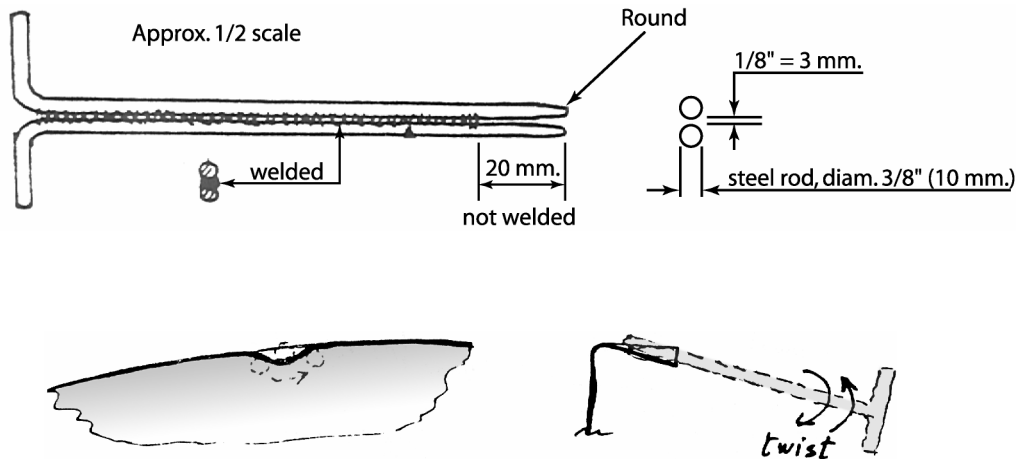

Flycutter:

The central locating hole is 1/4" (or the flycutter pilot drill diameter). Adjust the flycutter as follows:

- Preferably use a drill press.
- Use a piece of wood under the sheet, and pull the cutter down SLOWLY.
- Make a groove equal to 1/2 the thickness of the sheet, turn over and cut out completely.
- With file and sand paper, smooth the edge carefully all around.

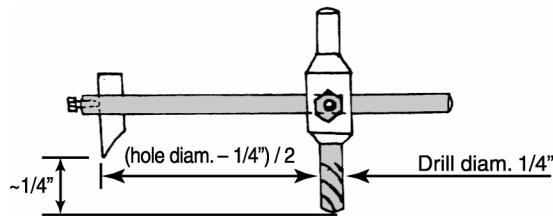

CORROSION PROTECTION: The ZODIAC aircraft has been designed to minimize corrosion as much as possible through the use of available materials (use of corrosion resistant 6061 alloy, cladding on the 2024 parts, no materials with large electro-potential difference in contact, etc.). If aircraft is based near the sea (salt or Na = sodium) or in a severely polluted industrial area (acid rain) the interior of the structure should all be primed with Zinc-chromate primer or other equally effective primers after first degreasing the surface. This should obviously be done before riveting the various parts together.

When applying corrosion protection, the minimum application is to cover the rivet line where parts are riveted or bolted together (such as the overlap of the rib flange with the wing skins). Covering the complete part takes a little longer and adds additional weight, however, it will give a more uniform application.

When to apply corrosion protection

In the kit the parts are supplied in the bare state, they have not been treated with a corrosion inhibitor: during storage keep the parts in a dry environment at all times. First drill and cleco the parts as shown in the drawings. Disassemble and deburr. Apply the primer on the internal structure, let dry completely. The traditional method is to apply Zinc Chromate primer on the individual parts.

Metal preparation for before priming

Gently scuff up the surface with a Scotch-bright general purpose hand pad 3M product P/N 7447+ (plastic pad similar to pad on back side of some sponges found around the kitchen!) do not use steel wool. De-grease the surface with a solvent on a clean rag, such as lacquer thinner. Apply the primer on both matting surface, let dry, then cleco the parts together for riveting. Only apply the primer on the inside surfaces only, the primer may not be compatible with the top coat or paint!

Zinc-Chromate (Zn-Cr) primer

Rear all safety labels: in some States ZnCr is prohibited (carcinogenic). Zinc chromate primer is still readily available by mail order from most aircraft supplier such as Aircraft Spruce 800-861-3192 part number 800-QT, Wicks Aircraft Supply 800-22-9425 www.wicks.com/aircraft or Wag-Aero 800-558-6868 www.wagaero.com.

It comes in a concentrated past much too heavy to brush on. You can either use the recommend solvent or simply use lacquer thinner as a reducer. With a spoon, scoop some out into another container, add solvent, stir to dissolve the past. Use a 2" bristle paint brush to apply the primer on the parts, if the solution look too light, add in some more of the paste: all that is required is a thin coat of uniform color. Avoid a thick heavy coat that can also become brittle and flack off! A single application is applied to each part, let it dry completely before assembly.

Brushing the primer on the parts is one way to avoid breathing over-spary or vapors that may otherwise be associated with spraying!

OTHER NEWER APPROACHES / ALTERNATIVES

Cortec tel. 734-213-1500

An alternative to Zinc Chromate is Cortec VCI 373, this is a water based primer to treat the internal structure. This product lends itself very to spraying with a HVLP spray equipment.

Corrosion X System, tel 800-638-7361

An alternative to applying primers is Corrosion X System, this is sprayed after the sections are assembled to wait until the entire plane is built and spray corrosion resistant oil on the internal parts. The oil finds its way through all the cracks and holes.

VARIOUS INFORMATION

SHEET METAL JOINTS: The skins overlap on top of each other. The drawings show the suggested position and rivet pitch of the sheet joints

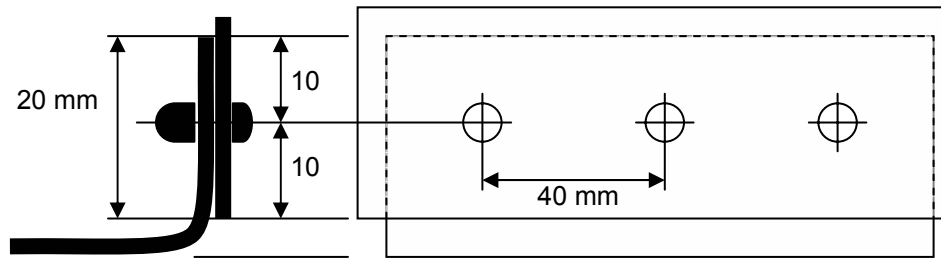

Rivet Spacing: 40 mm. = PITCH 40

SHIMMING: It is an acceptable and common practice to fill the gap between two parts which do not completely match. If you have to shim over 1/8" (3mm) refer to the designer.

Sheet metal edges: Use a body file to smoothen all edges to avoid cuts. But that is all; do not spend unnecessary time rounding off each corner..

WORK BENCH: 4X12FT or length of wing spar, minimum length = 8ft. Surface: 3/4" plywood is ideal.

STANDARD L ANGLE: The L Stiffeners are shown at the beginning of the wing section, designated throughout the drawings as a capital L inscribed in circle. t=.025" flanges 19x19mm bent at 90 degrees, supplied in length of 4 feet (trim to fit as required)

WELDING: Electric or gas welding for 4130 N and steel, heliarc for alum. fuel tank. In the kits, all the welding is done. Unless you are an experienced (and current) welder, subcontract all the welding (steel as well as the alum. gas tank), or purchase the welded parts

HEAT TREATMENT: Heat treatment is not a homebuilder's technique. The ZODIAC has been designed so that no heat treatment is required.

CRACKED OR DAMAGED PARTS: Replace every part which reveals cracks after manufacturing, and replace any otherwise damaged parts before assembling them. Cracks may occur when bending with too small a radius (remember $R > 3xt$), forgetting to sand the edges smooth, mishandling (tool or other marks ...).

VISUAL INSPECTION

Check for:

- Corrosion protection where applicable and on all steel parts.
- Do all rivets squeeze the matching parts tightly? No burrs in between?
- Proper edge distance?
- Are all items safety-tied as required? (cotter pin, locking wire, etc ...).
- Are the bolts tight and of correct length?

BUILDING THE WING RIBS (parts supplied finished in the kit)

The following applies to all the ribs and formed parts (wing, flaperons, tail & fuselage).

FORMING BLOCKS:

Draw the forming block coordinate on a 3/4" (20mm) good quality plywood; the X is the horizontal distance, Yu is the vertical distance for the upper curvature, Yl is the vertical distance to the lower curvature. It is a good idea, especially for the nose which have a small curvature, to countersink and screw a 1/8" (3mm) aluminum plate on the plywood to protect the wood during forming. Saw the blocks (band saw) slightly oversize, and finish by filing to the exact dimensions.

NOTE: Two identical, but right and left (R + L) blocks are required. The aluminum is for reinforcement purposes. Drawing shows the radius $R=1/8" = 3 \text{ mm.}$, and the 8 deg. cut back which is required for the 'spring back'.

Clamp both blocks carefully together and drill the 1/4" holes (center of the lightening holes) at 90 degrees. A 1/4" bolt will hold them together.

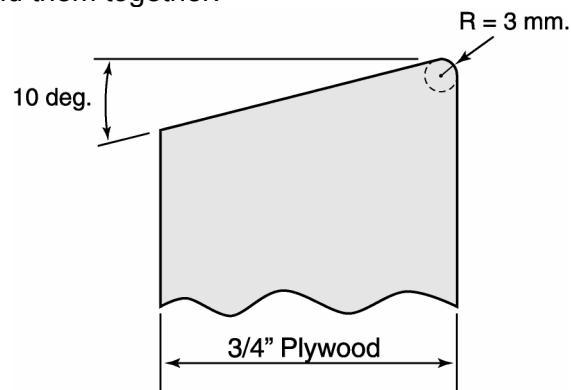

RIB BLANKS:

On the flat rib material (sheared roughly to size), draw the rib size with a felt tip marker by using the forming block (just draw all around). Then draw the 'cut line' 18mm larger (except at the leading edge where it is only 4 mm. larger) and the corners.

Also drill the 1/4" holes in the blanks (carefully: do not damage the blocks). Cut the rib blanks with the snips, file the edges smooth.

CRIMPING POSITION: for the CH 601UL and CH 601HD Nose Ribs 6V1-2 and Rear Ribs 6B1-3 (for the XL crimp positions are show on the drawings).

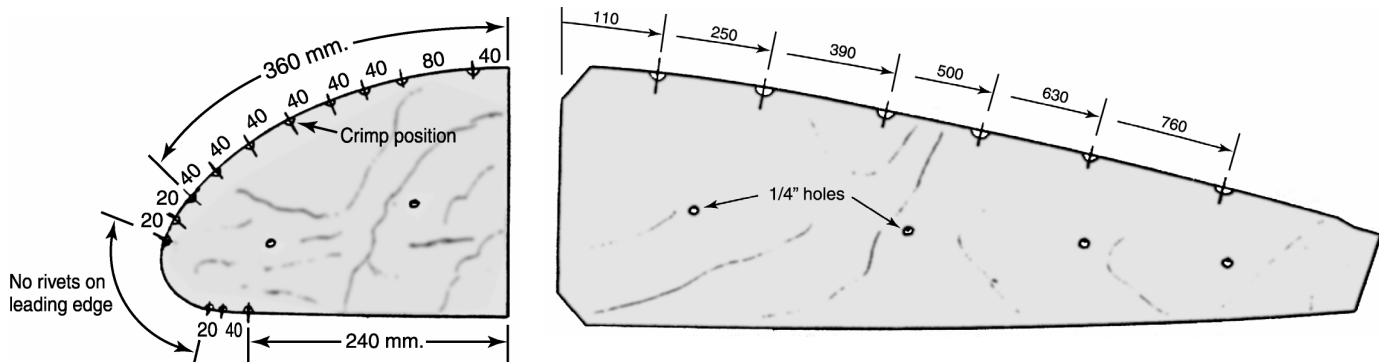

The crimps must be positioned where there will be no rivets installed later on. Mark following position on both blocks (dimensions in mm.).

Forming the ribs:

Clamp the rib blank between the two corresponding blocks with the ¼" bolts. The flange should protrude evenly. If there is more than 2 mm. variation, start all over again and be more careful. With the mallet, hammer the flange over:

1. Go all around and hammer flanges down about 30 deg. first.
2. Add the crimps using a crimping tool
3. The second time around, another 30 deg.
4. At the third time, hammer completely down on the block.



Be careful with the blocks as you need them to form more ribs. Mark the crimp position on the wavy rib flange, remove the rib from between the blocks. Crimp as required with the 'crimping tool' and the rib will flatten out and the flange will become straighter.

Finishing the Ribs:

A pair of pliers with rounded and filed tips, or the "hand seamer", will come in handy to finish straightening out the flange nicely in-between the crimps.

NOTE: On the leading edges the flange is very narrow, and no crimps are required. In this area there will be no rivets, however the rib is required to be accurately formed to support the nose skin in the exact way so that the airfoil profile (shape) is respected. Only the correct airfoil shape will give your aircraft the excellent low speed flying characteristics.

Remember: You need as many right hand as left hand ribs. The gear ribs are different than the others; the hole is flanged to the same side as the outer flange

NOTE: When the wing baggage lockers are installed, close the lightening holes to prevent small baggage or small objects from entering the wing...

FLANGED LIGHTENING HOLES: The flanging dies are as follows:

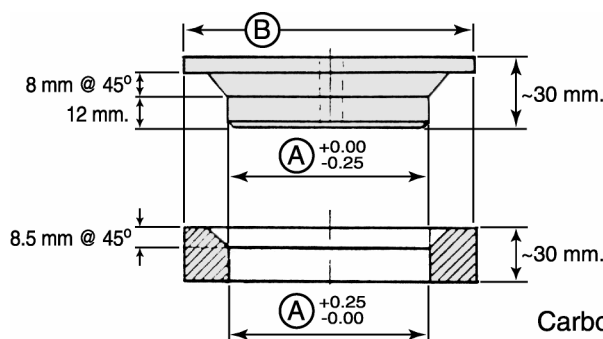

Flanging Die (Male & Female)
for standard lightening holes

	STD. 95	STD. 110
(A) =	95 mm.	110 mm.
(B) =	~127 mm.	~135 mm.

Carbon steel dies: Finish with emory cloth, r = 2 mm.

Place the cut out sheet on the female die, insert the male die (self-centering) and use any press to flange (even a 3/4" bolt and two plates, or a heavy vise will do a good job on the relatively thin sheet metal used).

SHEET METAL CONSTRUCTION

“aluminum-alloy, semi-monocoque, stressed skin construction”. This means that the metal used is some form of aluminum-based alloy, and that the airframe sections are designed and built so that the outer skin itself is part of the structure, with internal ribs, longerons, spar & doubler and bulkheads to distribute the loads. The metal parts are permanently joined with rivets or other fasteners. First assemble the skeleton then add the skin. SKELETON (Sections with a spar): rudder, stabilizer, wings, (elevator & flaperons 701, 801).

Pre-drilled holes: the skins are either supplied pre-drill or must be drilled with pilot holes before they can be installed on the skeleton or before any part is back drilled to the skins. *The pre-drilled skins are used to square the skeleton and to align the part, it is this innovative technique that eliminates the need for jigs or fixtures.*

Flange rivet lines: Line drawn with a soft felt tip marker the length of a flange that will overlap with the skin. Edge distance = $3d$ (distance from the edge of the flange to the center of the line = three times the diameter of the hole) example, for a 1/8 hole, $e = 10\text{mm}$).

Back-drilling: To drill through (open up) the pilot holes into the part. First position the Skin on top of the parts or skeleton assembly. Reach underneath the skin to adjust the position the of the parts (ribs, stiffeners or bulkhead) to line up the flange rivet line over the pre-drilled holes. Drilling and Cleco from the top of the skin when the flange rivet line is visible through the pre-drilled holes.

- 1) **Position:** Determine how the parts are positioned on the finished aircraft: identify the front side (forward & aft), Up direction, Inboard (I/B) and outboard (O/B) ends.
- 2) **Flanges:** Mark the flange rivet line on the side that will overlap with the skin. Do not pre-drill.
- 3) **Overlap:** Parts are joined together with rivets across the area where they overlap. Determine how the parts will overlap together. The objective is to plan ahead to avoid rivets spaced too close together or to place parts on top of rivets.
- 4) **No rivet zone:** Identifies an area of overlap across a rivet line with a part that cannot be installed now. When it is time to position the overlapping part, the holes will be drilled through the part into the no rivet zone to complete the rivet line.
- 5) **Layout:** The layout is the distance to, or position of the rivet lines. Determine the reference line (zero end) from which the distances are measured. Note: there is no single datum line or zero reference for the whole aircraft.
- 6) **Bolt holes,** (AN / MS hardware) drill the bolt holes first, then radius the part (radius is from the center of the bolt hole to the edge of the part). Position the part with reference to the bolt hole, then mark the rivet line.
- 7) **Rivet lines:** A4 pitch 40 is an example of how rivets lines are shown in the drawings (A4 refers to type of rivet). Pay attention to the following points to locate the rivets:
 - a) Edge distance: the position of the rivet line from the edge of the part.
 - b) End holes: The last hole in a rivet line. These are set first at the edge distance from each end of the part on the rivet line.
 - c) Intersection holes: Where two rivet line cross. Treat intersection holes as end holes to set the rivet pitch.
 - d) Rivet pitch: divide the distance between end hole for individual rivet spacing.
 - e) Crimps: check that the rivets do not coincide with the crimps (rib flanges).
- 8) **Cut:** Trim to fit. Taper or chamfer ends (extrusions). Use sheet metal snips for material thickness up to .040”; cut through one sheet at a time.
- 9) **Drill & Cleco:** On longer rivet lines it is not necessary to Cleco every hole, drill and Cleco every third hole, then go back and drill the in between holes.

Riveting: Before riveting disassemble the parts, deburr and prime (apply corrosion protection). Re-assemble with Clecos. Check that the assembly is not twisted then rivet. IMPORTANT, the A4 & A5 rivets require a special machined nose piece on the riveter to form the domed head on the rivets.

RIVET INSPECTION: If there is a questionable gap between edge of the rivet and the skin, drill it out and replace it (to set the rivet properly, hold the riveter square to the skin).