

77.5 degrees
REAR CHANNEL
PLYWOOD TEMPLATE

Ref. 6-B-14



Top and bottom are square to the front edge (vertical distance)

Make following template:
Vertical distance = 300mm
Layout dimensions shown in the bottom right table on drawing 6-B-14



77 degrees
FIREWALL PLYWOOD
TEMPLATE

REF. 6-B-14

CHECK: Use a square to check that the front edge is square to the top edge. (90 degrees)

Make a plywood template.
Vertical distance = 460mm
Layout dimensions shown in the bottom right table on drawing 6-B-14



81 degrees
CENTER SPAR
TEMPLATE

Make a plywood template.
Vertical distance 485mm
Layout dimensions shown in the bottom right table on drawing 6-B-14



CHECK: Lay a straight edge on the plywood template to check that it is straight.

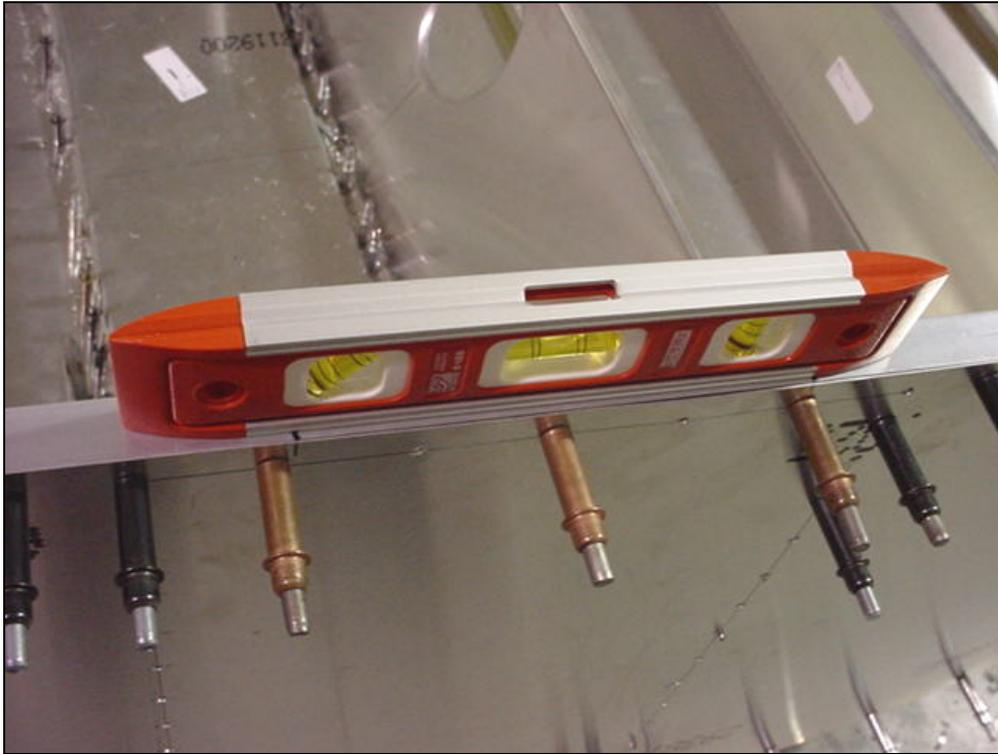

6" SPIRIT LEVEL

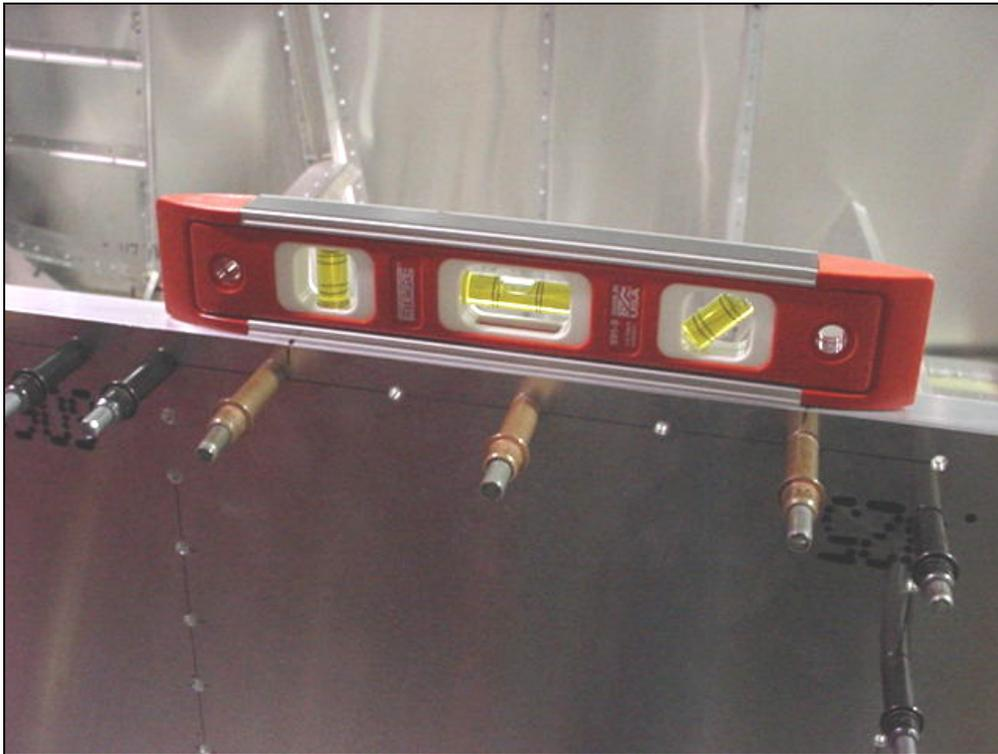

Top and bottom sides of template are level.

CHECK
Turn the level over to confirm that the ball is still in the middle

WING JIG 6-B-13

Spar insert and
1"x1-1/2" extrusion

Note: The inboard end of
the spar insert has no
rivets.



PURPOSE: The wing jig should be an exact duplicate of the root section of the wing (wing portion that bolts to the fuselage).



The 1" flange overlaps the
spar insert.

Extrusion is used to connect the spar insert to the web template.

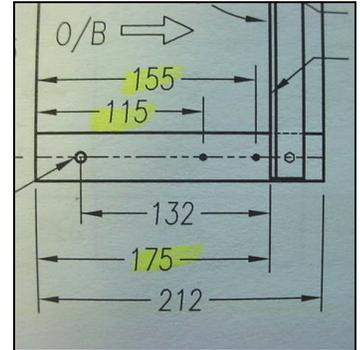
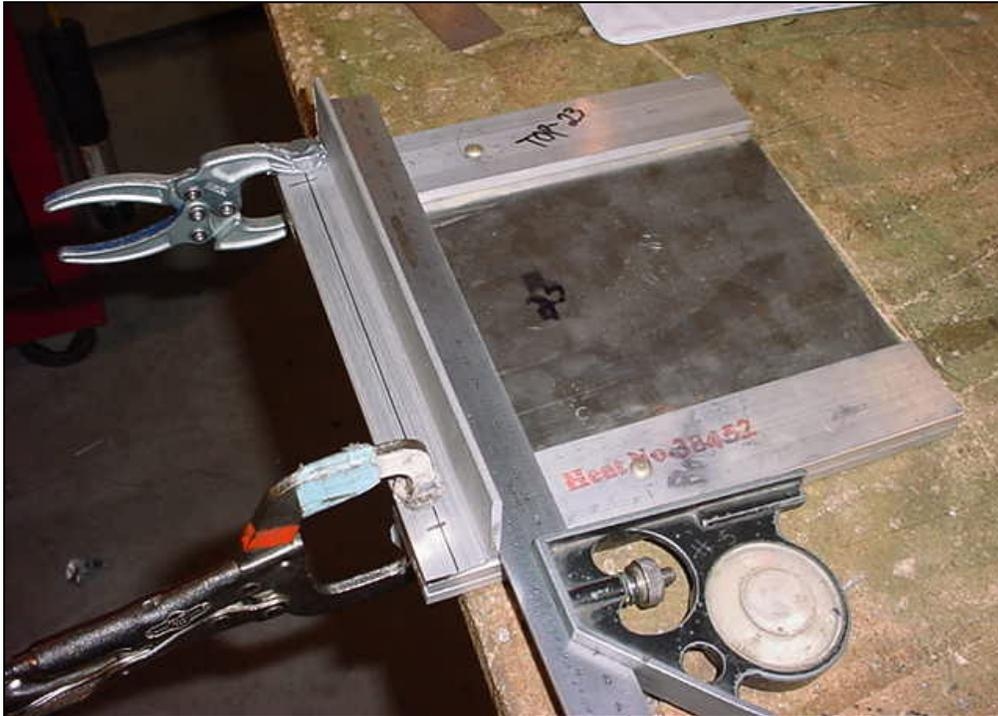

Clamp the extrusion 175mm from the end of the spar insert.



Bolt the extrusion to the spar insert.

Holes are 19mm from the top edge of the cap (approximately 175mm vertical distance between holes).

To assure alignment with the pre-drilled holes in the center spar 6-W-4, oversize the holes in the spar insert. The main purpose of the spar insert is to act as a spacer to fit between the front and rear spar insert (The oversized holes in the spar insert will have negligible effect on the dihedral angle).

Bottom hole is 17mm further inboard than the top hole.

Ref top right diagram on drawing 6-W-3

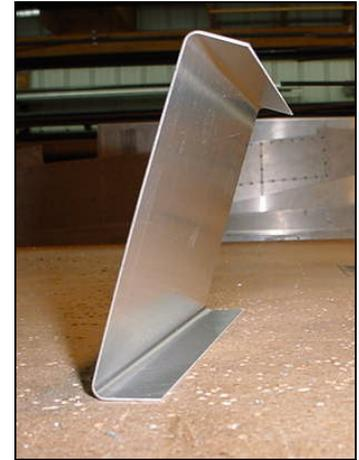

ORIENTATION:
90 degrees flange is up.

REAR CHANNEL.
Rivet the piece of angle 50mm from the I/B end of the channel.



Piece of angle is 3
degrees closed (to
connect the rear channel
to the web template).

Clamp.
Drill and Cleco.



WEB TEMPLATE
 Supplied in kit: 6061-t6
 t=.090"

Level the top template.



Check rear angle

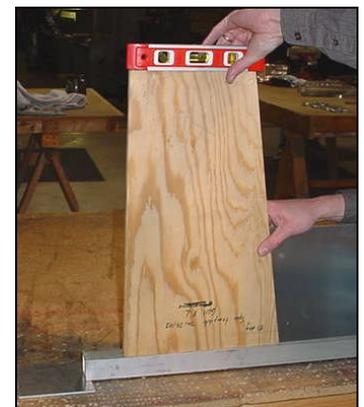

Check from angle.

Note: It is not critical for the bottom of the template to be level. If necessary raise an end until level.



Spar insert and rear channel assembly ready to be clamped to spar web.



Clamp the spar insert to the web template.
Check angle.
Drill and Cleco.



Check: That the top of web template is level.



Turn the template over to double check the angle.



CHECK: 75mm from top aft corner to top of channel.

Top of channel is square with side of web template.



Clamp the Rear Channel assembly to the web template.
Check angle.
Drill and Cleco.



Each time before checking angles, check that the top of the web template is level.

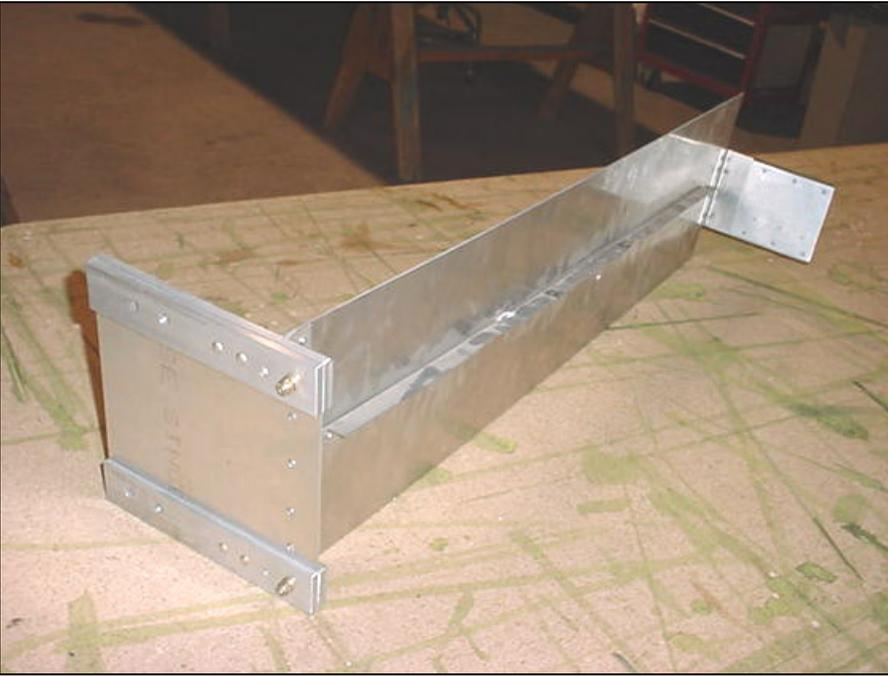

WING JIG
Ref 6-B-13



The top of the web must be flush with the top of the spar insert.

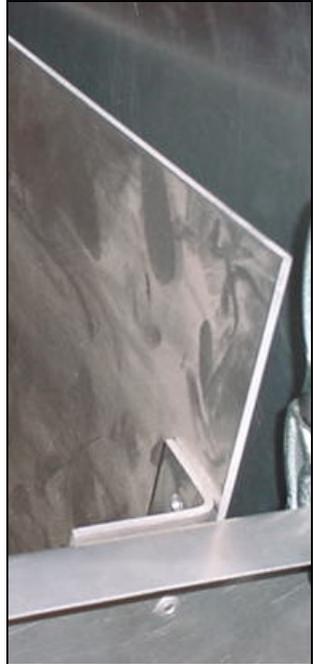

75mm from top of web template to top flange of rear channel.

Left side, outboard side.
Add the reinforcement L angles to keep the web template straight.

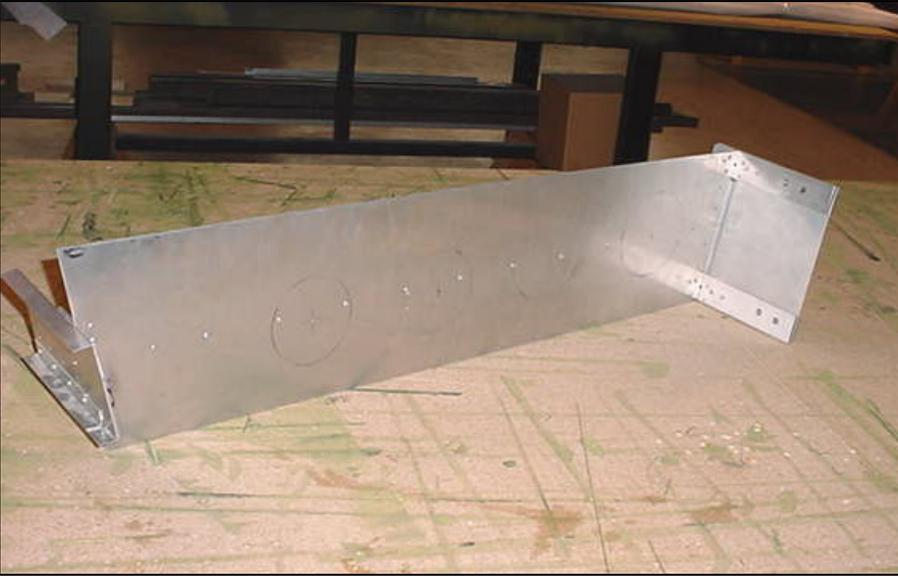

Wing Jig fit for left side, photo to show inboard side.

Bolt and rivet.

CHECK: The distance between the end of the rear channel and the spar insert is exactly the same as measured on the wing.